

# MAGNEHELIC® DIFFERENTIAL PRESSURE INDICATING TRANSMITTER

Same Size as Standard Magnehelic® Differential Pressure Gage

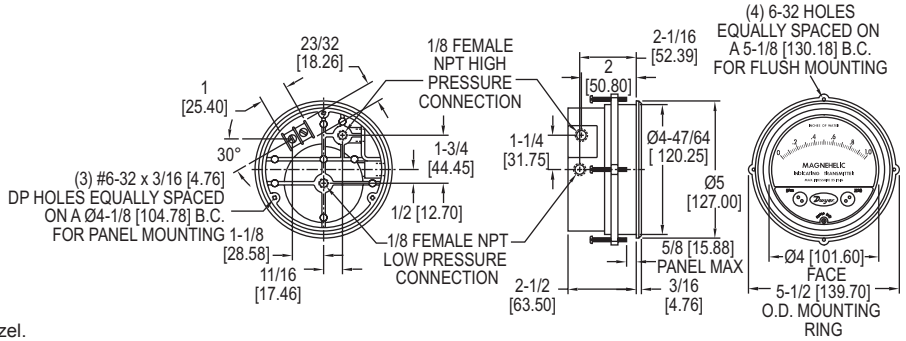

**Note:** Shown with optional -SS bezel.  
Backward compatible\* with Magnehelic® gage.



The Series 605 Magnehelic® Differential Pressure Indicating Transmitter provides for both visual monitoring and electronic control of very low differential pressure. The Series 605 is ideal for control applications in building HVAC systems where local indication is desired during routine maintenance checks or necessary when trouble shooting the system. The easily read dial gage is complimented by the two-wire, 4 to 20 mA control signal utilizing the time-proven Dwyer® Magnehelic® gage mechanical design and Series 600 transmitter technology. The two-wire design with terminal strip on the rear simplifies connection in any 4 to 20 mA control loop powered by a 10-35 VDC supply.

**FEATURES/BENEFITS**

- Easy to read gage permits viewing from far away
- Patented design provides quick response to pressure changes means no delay in signaling and alerting to critical situations
- Durable and rugged housing and high-quality components combined provides long-service life and minimized down-time
- Optional stainless steel bezel is the same installation diameter as Magnehelic® gage and simplifies field upgrade to 605 indicating transmitter

**APPLICATIONS**

- Monitor pressures in ducts, rooms, or total building pressures
- Filter monitoring
- Local indication of clean room pressures with process signal sent to control room

MODEL CHART				
Model	Range in w.c.	Maximum Pressure	Electrical Accuracy ±%	Mechanical Accuracy ±%
605-00N	0.05-0-0.2	25 psi (1.7 bar)	4	4
605-11	0 to ±.25	25 psi (1.7 bar)	2	3
605-0	0 to .50	25 psi (1.7 bar)	2	3
605-1	0 to 1.0	25 psi (1.7 bar)	2	2
605-2	0 to 2.0	2 psi (13.79 kPa)	0.5	2
605-3	0 to 3.0	2 psi (13.79 kPa)	0.5	2
605-6	0 to 6.0	2 psi (13.79 kPa)	0.5	2
605-10	0 to 10	2 psi (13.79 kPa)	0.5	2
605-20	0 to 20.0	11 psi (75.8 kPa)	0.5	2
605-30	0 to 30	11 psi (75.8 kPa)	0.5	2
605-50	0 to 50	11 psi (75.8 kPa)	0.5	2
Model	Range in Pa	Maximum Pressure	Electrical Accuracy ±%	Mechanical Accuracy ±%
605-12	0 to ±60	25 psi (1.7 bar)	4	4
605-13	0 to ±100	25 psi (1.7 bar)	2	2
605-60PA	0 to 60	25 psi (1.7 bar)	2	4
605-125PA	0 to 125	25 psi (1.7 bar)	2	3
605-250PA	0 to 250	25 psi (1.7 bar)	2	2
605-500PA	0 to 500	2 psi (13.79 kPa)	0.5	2

OPTIONS	
To order add suffix:	Description
-SS	304 brushed stainless steel bezel. *Backward compatible with standard Magnehelic® gage installation diameter
<b>Example:</b> 605-3-SS	
-NIST	NIST traceable calibration certificate
<b>Example:</b> 605-3-NIST	

**SPECIFICATIONS**

**GAGE SPECIFICATIONS**

- Service:** Air and non-combustible, compatible gases.
- Wetted Materials:** Consult factory.
- Accuracy:** See chart.
- Stability:** ±1% FS/yr.
- Pressure Limits:** See chart.
- Temperature Limits:** 20 to 120°F (-6.67 to 48.9°C).
- Process Connections:** 1/8" female NPT.
- Size:** 4" (101.6 mm) dial face, 5" (127 mm) OD x 2-11/16" (68.3 mm); -SS bezel: 4-3/4" (120.7 mm) OD x 2-21/32 (67.5 mm).
- Weight:** 1 lb 12.6 oz (811 g).
- Agency Approvals:** CE.

**TRANSMITTER SPECIFICATIONS**

- Accuracy:** See chart (includes linearity, hysteresis, repeatability).
- Temperature Limits:** 20 to 120°F (-6.67 to 48.9°C).
- Compensated Temperature Range:** 32 to 120°F (0 to 48.9°C).
- Thermal Effect:** ±0.025% FS/°F (0.045% FS/°C).
- Power Requirements:** 10 to 35 VDC (2-wire).
- Output Signal:** 4 to 20 mA.
- Zero and Span Adjustments:** Protected potentiometers.
- Loop Resistance:** DC: 0 to 1250 Ω max.
- Current Consumption:** DC: 38 mA max.
- Electrical Connections:** Screw terminal block.
- Mounting Orientation:** Diaphragm in vertical position. Consult factory for other position orientations.

**ACCESSORIES**

Model	Description
A-298	Flat aluminum bracket for flush mounting
A-370	Mounting bracket; flush mount Series 605 transmitter in bracket; bracket is then surface mounted; steel with gray hammertone epoxy finish

Static Fitting Options: See page 502 (Static Pressure Tips)  
Process Tubing Options: See page 503 (Gage Tubing Accessories)