



aerospace
climate control
electromechanical
filtration
fluid & gas handling
hydraulics
pneumatics
process control
sealing & shielding



Compact Pneumatic Cylinders P1P Series

According to ISO 21287

Catalogue PDE2660TCUK February 2012



Features	3 - 4
Technical Information	
General technical data	5
Operating and environmental data	5
Material specification	5
Cylinder forces	6
Application Guide	7
Order code key	8
Standard stroke length	8
Common part numbers	9
Dimensions	
Double acting with female piston rod thread	10
Double acting with guided piston rod	10
Double acting with male piston rod thread	11
Mountings	
Flange	12
Foot bracket	12
Pivot bracket with rigid bearing	13
Clevis bracket MP2	13
Clevis bracket MP4	14
Clevis bracket GA	14
Pivot bracket with swivel bearing	15
Swivel eye bracket	15
Mounting kit	16
Swivel rod eye	17
Clevis	17
Flexo coupling	18
Nut	18
Accessories	
Sensors	19 - 21
Air Quality	22

 **WARNING**

FAILURE OR IMPROPER SELECTION OR IMPROPER USE OF THE PRODUCTS AND/OR SYSTEMS DESCRIBED HEREIN OR RELATED ITEMS CAN CAUSE DEATH, PERSONAL INJURY AND PROPERTY DAMAGE.

This document and other information from Parker Hannifin Corporation, its subsidiaries and authorized distributors provide product and/or system options for further investigation by users having technical expertise. It is important that you analyze all aspects of your application including consequences of any failure, and review the information concerning the product or system in the current product catalog. Due to the variety of operating conditions and applications for these products or systems, the user, through its own analysis and testing, is solely responsible for making the final selection of the products and systems and assuring that all performance, safety and warning requirements of the application are met.

The products described herein, including without limitation, product features, specifications, designs, availability and pricing, are subject to change by Parker Hannifin Corporation and its subsidiaries at any time without notice.

Offer of Sale

The items described in this document are hereby offered for sale by Parker Hannifin Corporation, its subsidiaries or its authorized distributors. This offer and its acceptance are governed by the provisions stated on the separate page of this document entitled "Offer of Sale".



P1P Compact Cylinder according to ISO 21287

The P1P Series is a complete range of ISO 21287 compact cylinders developed to meet the highest requirements for quality and performance. The careful design in every detail provides first class function and service life properties.

Features

- ISO 21287 conformity and global availability throughout the worldwide Parker Hannifin organization.
- Product launch starts with 32, 40, 50 and 63mm bore sizes followed by other sizes shortly after.
- One of the widest ranges of sizes and versions for a broad range of applications.
- Corrosion resistant design with end covers and barrel in anodized aluminium and stainless steel piston rod.
- Long service life thanks to proven high quality materials, surfaces and seal technology.
- Compact design and many installation alternatives for flexible use in narrow spaces.
- Efficient elastic cushioning absorbing residual energy facilitates high speeds and short cycle times.
- Smooth, low noise operation thanks to elastic material in end faces of the piston.
- Flush, drop in global P8S-G sensors on all side faces for flexible and compact assembly and mechanical protection of the sensors.
- P1P is suitable for processing, packaging and handling applications within the food industry thanks to the food approved grease used for the initial greasing.

High quality

Reliability and long service life are key qualities of any pneumatic cylinder. Therefore we have given P1P highest possible quality in every detail based on our 40 years of experience and extensive testing. The design is based on the following important principles.

- Proven seal design and materials throughout the cylinder. The expertise for seal technology within Parker Hannifin is the basis for leading and proven tribology solutions for all our pneumatic actuators.
- Body extrusion in anodised aluminium with extra fine and hard internal surface for optimum operational conditions.
- End covers and body extrusion with external anodisation for excellent corrosion resistance.
- Stainless steel piston rod for versatile use in corrosive environment.

Compact dimensions for versatile use

The very compact axial dimensions makes it possible to use the P1P cylinders in a broad range of applications. Note that the P1P cylinders are up to 50% shorter than ISO 15552 cylinders for the same stroke length. This is highly valuable in narrow spaces in machines or production lines. The P1P range is a truly versatile cylinder family.

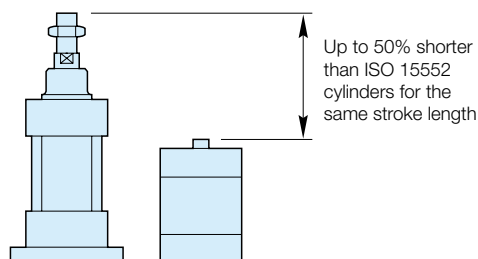

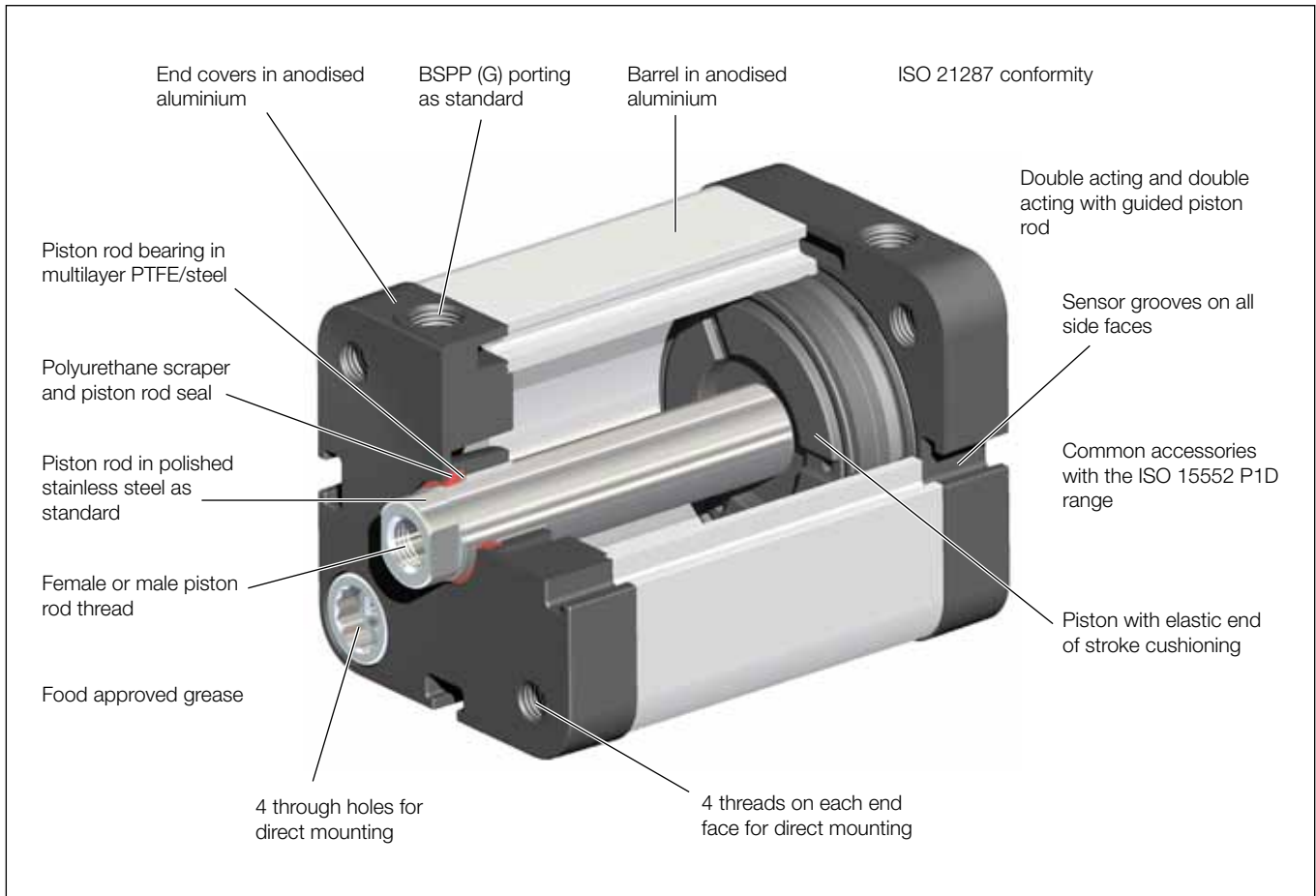

Flexible installation

The new P1P compact cylinder range offers many opportunities for mechanical installation.

- There are holes through the cylinder body. Use these to fix the cylinder with through bolts into threads in the surface behind the cylinder.
- In each end of the same through holes there are female threads. These can be used for flange mounting of the actuator from the rear or front face.
- The wide range of ISO 15552 cylinder mountings are available for use with P1P cylinders bore 32-63 mm. Examples are the foot and flange mountings, as well as MP2 and MP4 mountings for articulated applications.

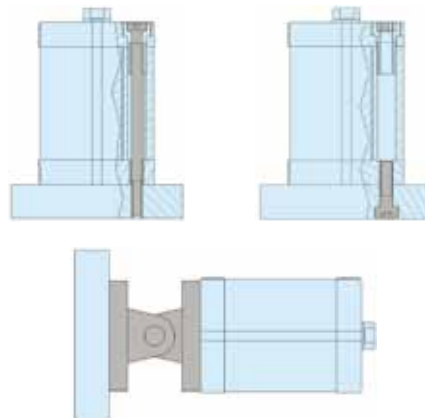

Global drop-in P8S-G sensor range

The global sensor range P8S-G fits P1P as well as most of our pneumatic cylinder families. This simplifies your ordering, stock and overall service of sensors.

The P8S-G sensors has a drop-in mounting into the sensor grooves facilitating the assembly and commissioning work. There are sensor grooves on all four side faces for maximum flexibility and adaptation to each application.

The wide range of P8S-G sensors includes both reed and solid state sensors, flying lead versions with 3 and 10 meter cable and pig tail versions with M8 and M12 connector.

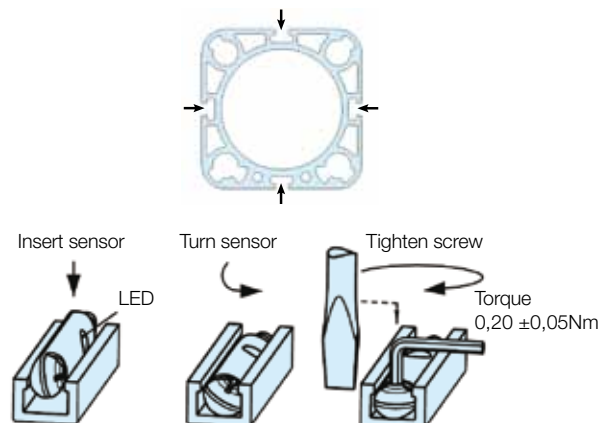

General technical data

Product type	Compact cylinder according to ISO 21287	
Bore size	32 - 63 mm	
Stroke length	1 - 500 mm	
Versions	P1PS...DS	Double acting
	P1PG...DS	Double acting with non rotating piston rod
Cushioning	Elastic cushioning	
Position sensing	Proximity sensor	
Installation	Direct	Through holes Female thread on front and rear end face
	Accessories	Cylinder and piston rod mountings
Mounting position	Any	

Operating and environmental data

Operating medium	For best possible service life and trouble-free operation it is recommended to use dry, filtered compressed air to ISO 8573-1:2010 quality class 3.4.3. This specifies a dew point of +3°C for indoor operation (a lower dew point should be selected for outdoor operation) and is in line with the air quality from most standard compressors with a standard filter. Refer to page 22.	
Operating pressure	0.5 bar to 10 bar	
Ambient temperature	Standard version	-20°C to +80°C
Pre-lubricated	Further lubrication is normally not necessary. If additional lubrication is introduced it must be continued.	
Corrosion resistance	High resistance to corrosion and chemicals. Materials and surface treatment have been selected for industrial applications where solvents and detergents are frequently used.	

Material specification

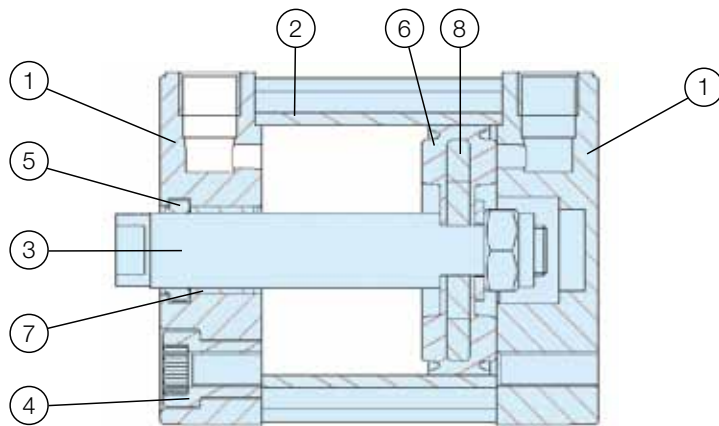

Pos	Part	Specification
1	End covers	Anodised aluminium
2	Cylinder barrel	Anodised aluminium
3	Piston rod	Standard Stainless steel, DIN X 10 CrNiS 18 9
4	End cover screws	Zinc plated steel
5	Piston rod seal	Polyurethane
6	Piston / piston seal	Steel / Nitrile rubber
7	Piston rod bearing	Multilayer PTFE/steel
8	Magnet	Plastic coated magnetic material
	Note on materials	RoHS compliant

Cylinder forces, double acting variants

Cylinder bore mm	Stroke	Bore mm	Piston rod mm	Area cm ²	Max theoretical force in N (bar)										
					1.0 bar	2.0 bar	3.0 bar	4.0 bar	5.0 bar	6.0 bar	7.0 bar	8.0 bar	9.0 bar	10.0 bar	
32	Double acting	+	32	12	8.0	79	158	237	315	394	473	552	631	710	789
		-	32	12	6.9	68	136	203	271	339	407	474	542	610	678
40	Double acting	+	40	12	12.6	123	246	370	493	616	740	863	986	1109	1233
		-	40	12	11.4	112	224	336	448	561	673	785	897	1010	1122
50	Double acting	+	50	16	19.6	193	385	578	770	963	1155	1348	1540	1733	1925
		-	50	16	17.6	173	346	518	691	864	1037	1210	1382	1555	1728
63	Double acting	+	63	16	31.2	306	611	917	1223	1528	1834	2140	2445	2751	3056
		-	63	16	29.1	286	572	858	1144	1430	1716	2002	2287	2573	2864

+ = Outward stroke
- = Return stroke

Note: Select a theoretical force 50-100% larger than the force required.

Technical data

Cylinder designation	Cylinder bore		Piston rod area		Piston rod thread	Total mass		Air consumption litres ⁽¹⁾	Port size
	mm	cm ²	mm	cm ²		at 0 mm stroke kg	addition per 10 mm stroke kg		
P1PS...DS7G Double acting with female piston rod thread									
P1PS032	32	8.0	12	1.1	M8 x 1.25	0.291	0.030	0.105	G1/8
P1PS040	40	12.6	12	1.1	M8 x 1.25	0.375	0.036	0.162	G1/8
P1PS050	50	19.6	16	2.0	M10 x 1.5	0.519	0.050	0.253	G1/8
P1PS063	63	31.2	16	2.0	M10 x 1.5	0.743	0.059	0.414	G1/8
P1PS...DS8G Double acting with male piston rod thread									
P1PS032	32	8.0	12	1.1	M10 x 1.25	0.308	0.030	0.105	G1/8
P1PS040	40	12.6	12	1.1	M10 x 1.25	0.392	0.036	0.162	G1/8
P1PS050	50	19.6	16	2.0	M12 x 1.25	0.548	0.050	0.253	G1/8
P1PS063	63	31.2	16	2.0	M12 x 1.25	0.772	0.059	0.414	G1/8
P1PG...DS7G Double acting with guided piston rod									
P1PS032	32	8.0	12	1.1		0.358	0.033	0.105	G1/8
P1PS040	40	12.6	12	1.1		0.455	0.039	0.162	G1/8
P1PS050	50	19.6	16	2.0		0.664	0.057	0.253	G1/8
P1PS063	63	31.2	16	2.0		0.930	0.067	0.414	G1/8

⁽¹⁾ Free air consumption per 10 mm stroke length for a double stroke at 6 bar

Selecting Pneumatic System Components

Cylinder to Valve: The below chart contains recommendations for selecting air valve products based on 5.5 bar with a 0.35 bar pressure drop. The values within the chart show the corresponding Cv values.

Moduflex Valve System

- Stand-alone valves, short-build valve manifold, or large valve manifold configurations available
- Cv range from 0.18 – 0.80
- Peripheral modules available— flow control, pressure regulation, P.O. check valves and vacuum generators



Cylinder speed (mm/s)	Cylinder bore size			
	32	40	50	63
50	0.03	0.04	0.06	0.10
100	0.05	0.08	0.13	0.20
150	0.08	0.12	0.19	0.30
200	0.10	0.16	0.26	0.41
250	0.13	0.20	0.32	0.51
300	0.16	0.25	0.38	0.61
350	0.18	0.29	0.45	0.71
400	0.21	0.33	0.51	0.81
450	0.24	0.37	0.58	0.91
500	0.26	0.41	0.64	1.10
	Size 1	Size 2		See larger valve system

Micro / ISO Valve System

- Isys Micro Cv range 0.30 – 0.35
- IsysNet system fieldbus, Turck system fieldbus, 25 pin D-sub, or low cost Moduflex fieldbus options available
- Isys ISO offers 5 sizes with Cv range 0.55 – 6.0



Cylinder speed (mm/s)	Cylinder bore size				Valve range
	32	40	50	63	
50	0.03	0.04	0.06	0.10	Isys Micro
100	0.05	0.08	0.13	0.20	
150	0.08	0.12	0.19	0.30	
200	0.10	0.16	0.26	0.41	HB
250	0.13	0.20	0.32	0.51	HA
300	0.16	0.25	0.38	0.61	
350	0.18	0.29	0.45	0.71	
400	0.21	0.33	0.51	0.81	
450	0.24	0.37	0.58	0.91	
500	0.26	0.41	0.64	1.10	

Order Code Key

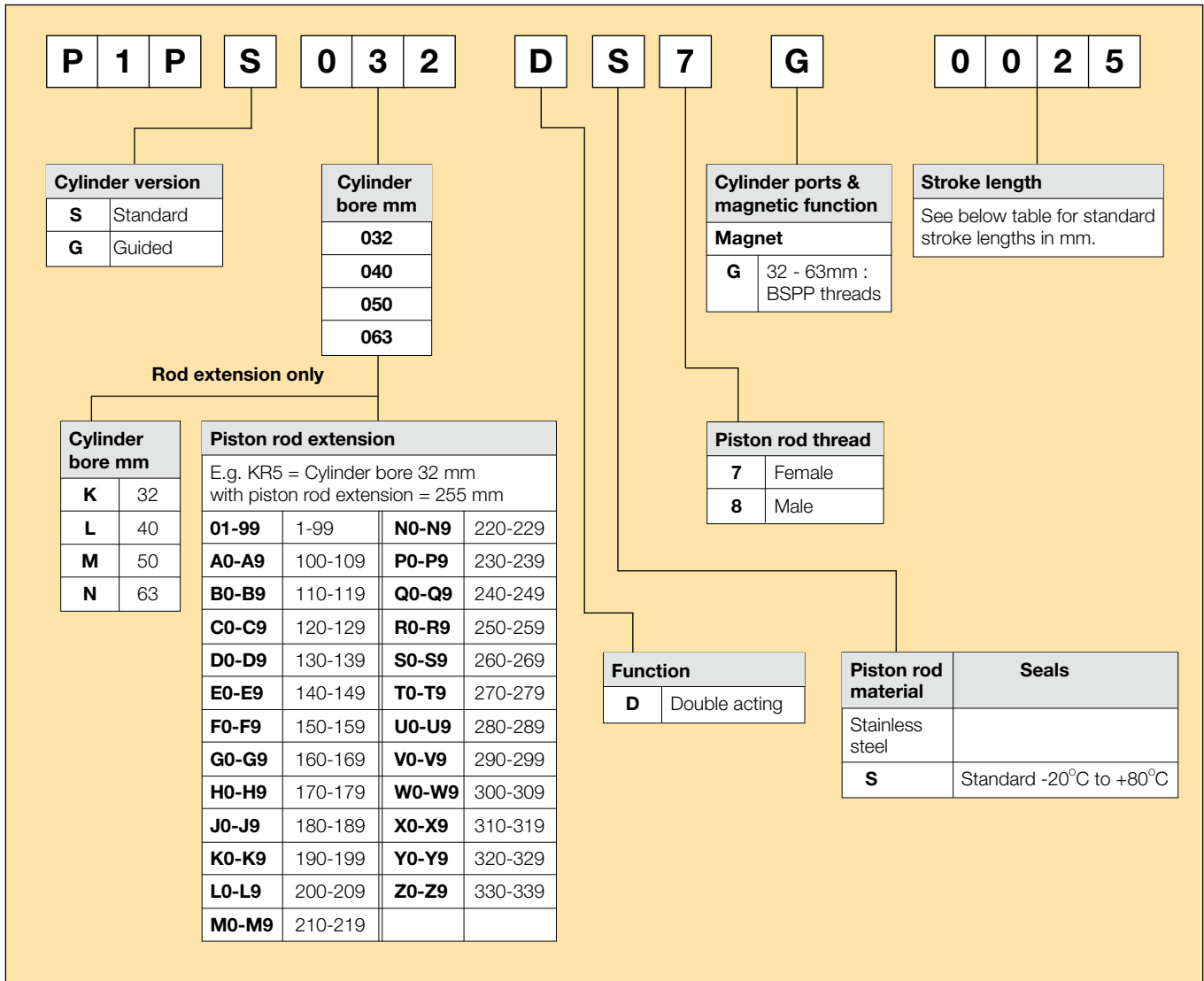

Standard stroke length

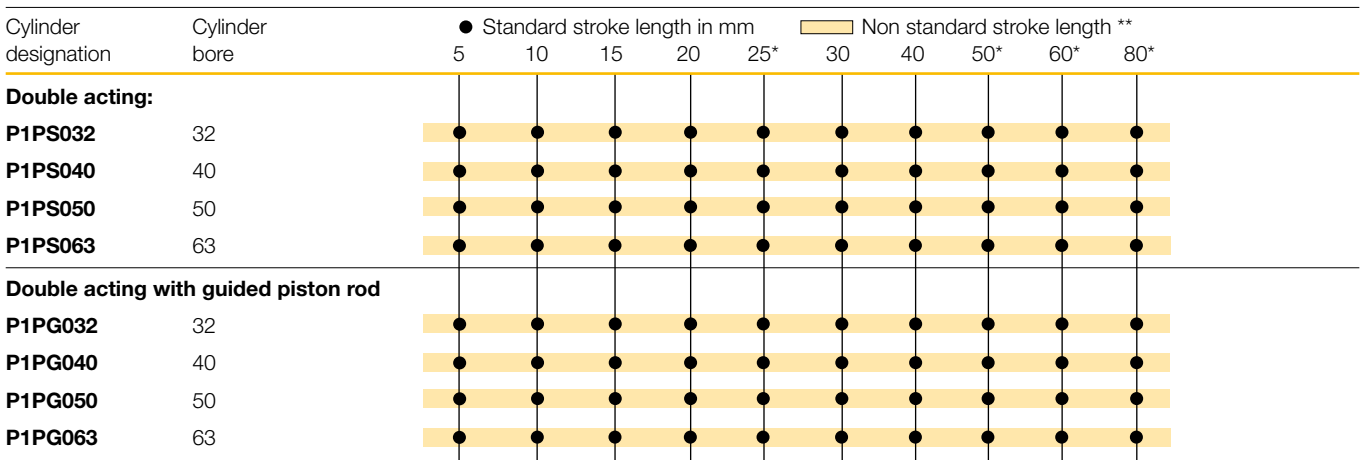

* Standard stroke lengths in mm according to ISO 4393
 ** Max stroke 500 mm

Double acting with female piston rod thread

- Bore 32-63 mm with ISO 21287 conformity
- Double acting with female piston rod thread
- Ideal for applications where space is at a premium
- Corrosion resistant thanks to use of anodised aluminium and stainless steel
- Elastic cushioning facilitates high speeds and short cycle times.
- Flexible direct mounting with through holes and threads
- Wide range of mountings and drop-in sensors



Ø 32mm - (G1/8)

Stroke (mm)	Order code
5	P1PS032DS7G0005
10	P1PS032DS7G0010
15	P1PS032DS7G0015
20	P1PS032DS7G0020
25	P1PS032DS7G0025
30	P1PS032DS7G0030
40	P1PS032DS7G0040
50	P1PS032DS7G0050
60	P1PS032DS7G0060
80	P1PS032DS7G0080

Ø 40mm - (G1/8)

Stroke (mm)	Order code
5	P1PS040DS7G0005
10	P1PS040DS7G0010
15	P1PS040DS7G0015
20	P1PS040DS7G0020
25	P1PS040DS7G0025
30	P1PS040DS7G0030
40	P1PS040DS7G0040
50	P1PS040DS7G0050
60	P1PS040DS7G0060
80	P1PS040DS7G0080

Ø 50mm - (G1/8)

Stroke (mm)	Order code
5	P1PS050DS7G0005
10	P1PS050DS7G0010
15	P1PS050DS7G0015
20	P1PS050DS7G0020
25	P1PS050DS7G0025
30	P1PS050DS7G0030
40	P1PS050DS7G0040
50	P1PS050DS7G0050
60	P1PS050DS7G0060
80	P1PS050DS7G0080

Ø 63mm - (G1/8)

Stroke (mm)	Order code
5	P1PS063DS7G0005
10	P1PS063DS7G0010
15	P1PS063DS7G0015
20	P1PS063DS7G0020
25	P1PS063DS7G0025
30	P1PS063DS7G0030
40	P1PS063DS7G0040
50	P1PS063DS7G0050
60	P1PS063DS7G0060
80	P1PS063DS7G0080

Double acting with guided piston rod

- Bore 32-63 mm
- Double acting with non rotating linear movement
- For fixing, clamping and moving anti rotate applications
- Anodised end covers, tool plate and barrel
- Stainless steel guide rods and piston rod as standard
- Flexible direct mounting with through holes and threads
- Wide range of mountings and drop-in sensors



Ø 32mm - (G1/8)

Stroke (mm)	Order code
5	P1PG032DS7G0005
10	P1PG032DS7G0010
15	P1PG032DS7G0015
20	P1PG032DS7G0020
25	P1PG032DS7G0025
30	P1PG032DS7G0030
40	P1PG032DS7G0040
50	P1PG032DS7G0050
60	P1PG032DS7G0060
80	P1PG032DS7G0080

Ø 40mm - (G1/8)

Stroke (mm)	Order code
5	P1PG040DS7G0005
10	P1PG040DS7G0010
15	P1PG040DS7G0015
20	P1PG040DS7G0020
25	P1PG040DS7G0025
30	P1PG040DS7G0030
40	P1PG040DS7G0040
50	P1PG040DS7G0050
60	P1PG040DS7G0060
80	P1PG040DS7G0080

Ø 50mm - (G1/8)

Stroke (mm)	Order code
5	P1PG050DS7G0005
10	P1PG050DS7G0010
15	P1PG050DS7G0015
20	P1PG050DS7G0020
25	P1PG050DS7G0025
30	P1PG050DS7G0030
40	P1PG050DS7G0040
50	P1PG050DS7G0050
60	P1PG050DS7G0060
80	P1PG050DS7G0080

Ø 63mm - (G1/8)

Stroke (mm)	Order code
5	P1PG063DS7G0005
10	P1PG063DS7G0010
15	P1PG063DS7G0015
20	P1PG063DS7G0020
25	P1PG063DS7G0025
30	P1PG063DS7G0030
40	P1PG063DS7G0040
50	P1PG063DS7G0050
60	P1PG063DS7G0060
80	P1PG063DS7G0080

Dimensions

P1PS...DS7G Double acting with female piston rod thread

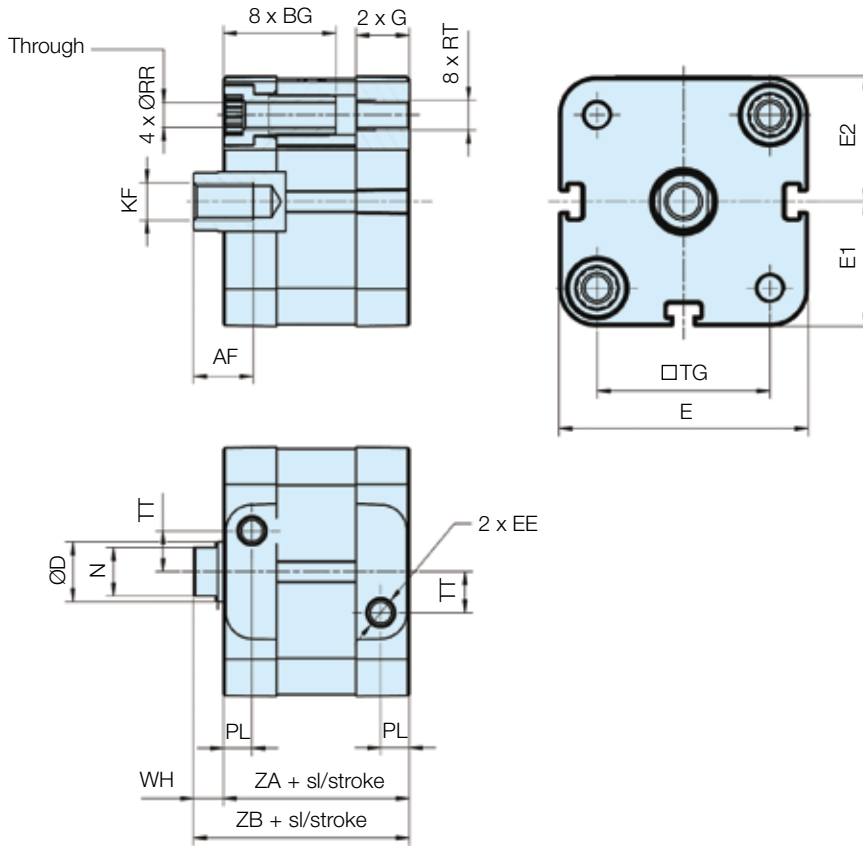

P1PG...DS Double acting with guided piston rod

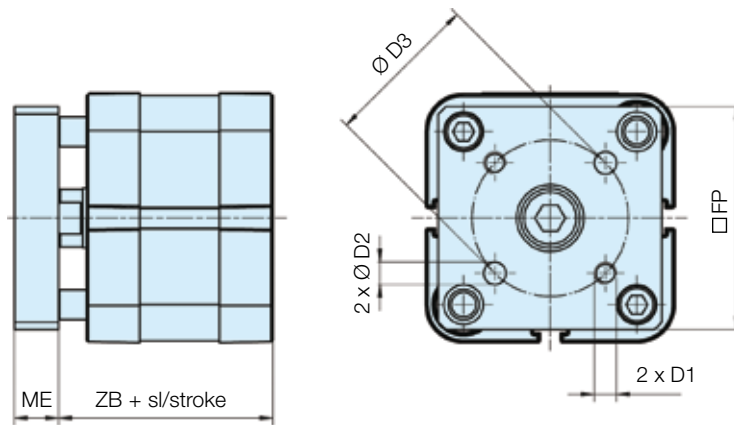

Bore size	AF	BG	ØD	D1	ØD2	ØD3	EE	E	E1	E2	FP	G	KF	ME	N	PL	ØRR	RT	TG	TT	WH	ZA	ZB
	min	min			H8										h14		min					± 0,3	± 0,6
Ø32	12	16	12	M5	5	28	G1/8	49,4	24,7	24,9	45	15,25	M8	10	10	7,8	5,1	M6	32,5	6,5	7	44	51
Ø40	12	16	12	M5	5	33	G1/8	56,0	28,0	28,5	50	15,25	M8	10	10	8,0	5,1	M6	38,0	8,0	7	45	52
Ø50	16	16	16	M6	6	42	G1/8	67,0	33,5	33,7	60	14,30	M10	12	13	7,7	6,4	M8	46,5	11,0	8	45	53
Ø63	16	16	16	M6	6	50	G1/8	79,0	39,5	39,8	70	16,30	M10	12	13	8,0	6,4	M8	56,5	16,0	8	49	57

P1PS...DS8G Double acting with male piston rod thread

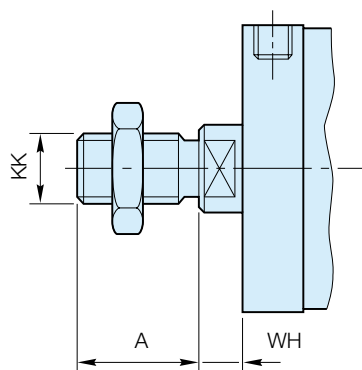

Bore size	A	WH		KK
		nom.	tol.	
	0 -0.05			
Ø32	19	7	± 1,6	M10 x 1,25
Ø40	19	7	± 1,6	M10 x 1,25
Ø50	22	8	± 1,6	M12 x 1,25
Ø63	22	8	± 1,6	M12 x 1,25

Note: Cylinders with male piston rod thread are delivered with one piston rod nut in zinc plated steel

Cylinder mountings

Flange MF1/MF2



Intended for fixed mounting of cylinder. Flange can be fitted to front- or rear end-plates of cylinder.

Materials
Flange: Surface-treated steel
Mounting screws according to DIN 6912: Zinc-plated steel 8.8

Supplied complete with mounting screws for attachment to cylinder.

Cyl. bore Ø mm	Weight kg	Order code
32	0,23	P1C-4KMB
40	0,28	P1C-4LMB
50	0,53	P1C-4MMB
63	0,71	P1C-4NMB

Ø32-100 according to ISO MF1/MF2, VDMA, AFNOR

Cyl. bore mm	d1 mm	FB mm	TG1 mm	E mm	R mm	MF mm	TF mm	UF mm	l1 mm	W mm	ZF* mm	ZB* mm	ZF2* mm	ZB2* mm
	H11	H13				JS14	JS14	JS14	-0,5					
32	30,0	7,0	32,5	45	32	10,0	64,0	80	5,0	2,0	58,5	48,5	67,0	57,0
40	35,0	9,0	38,0	52	36	10,0	72,0	90	5,0	2,0	60,5	50,5	68,5	58,5
50	40,0	9,0	46,5	65	45	12,0	90,0	110	6,5	4,0	64,5	52,5	71,0	59,0
63	45,0	9,0	56,5	75	50	12,0	100,0	120	6,5	4,0	70,0	58,0	75,5	63,5

S = Stroke length

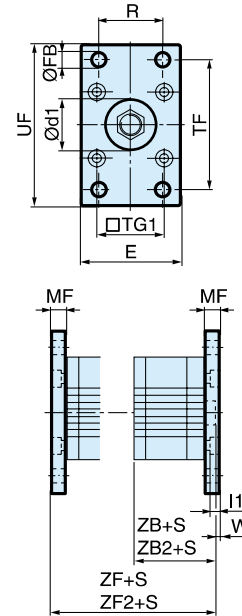

Foot bracket MS1



Intended for fixed mounting of cylinder. Angle bracket can be fitted to front- and rear end-plates of cylinder.

Materials
Foot bracket: Surface-treated steel, black
Mounting screws according to DIN 912: Zinc-plated steel 8.8

Supplied in pairs with mounting screws for attachment to cylinder.

Cyl. bore Ø mm	Weight kg	Order code
32	0,06**	P1C-4KMF
40	0,08**	P1C-4LMF
50	0,16**	P1C-4MMF
63	0,25**	P1C-4NMF*

** Weight per item

Ø32-63 according to ISO MS1, VDMA, AFNOR

Cyl. bore mm	AB mm	TG1 mm	E mm	TR mm	AO mm	AU mm	AH mm	I7 mm	AT mm	I9 mm	SA* mm	SA2* mm
	H14			JS14			JS15		JS14			
32	7,0	32,5	45	32	10,0	24,0	32	30,0	4,5	17,5	88,5	97,0
40	9,0	38,0	52	36	8,0	28,0	36	30,0	4,5	18,5	98,5	106,5
50	9,0	46,5	65	45	13,0	32,0	45	36,0	5,5	25,0	108,5	115,0
63	9,0	56,5	75	50	13,0	32,0	50	35,0	5,5	27,5	114,0	119,5

S = Stroke length

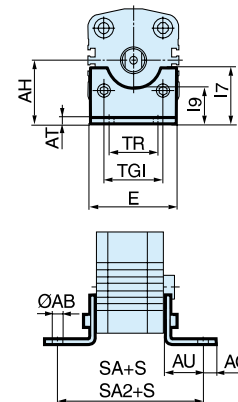

Cylinder mountings

Pivot bracket with rigid bearing



Intended for flexible mounting of cylinder. The pivot bracket can be combined with clevis bracket MP2.

Materials
 Pivot bracket: Surface-treated aluminium, black
 Bearing: Sintered oil-bronze bushing

Cyl. bore Ø mm	Weight kg	Order code
32	0,06	P1C-4KMD
40	0,08	P1C-4LMD
50	0,15	P1C-4MMD
63	0,20	P1C-4NMD

Ø32-63 according to CETOP RP 107 P, VDMA, AFNOR

Cyl. bore mm	CK H9 mm	S5 H13 mm	K1 JS14 mm	K2 mm	G1 JS14 mm	G2 JS14 mm	EM mm	G3 mm	CA JS15 mm	H6 mm	R1 mm
32	10	6,6	38	51	21	18	25,5	31	32	8	10
40	12	6,6	41	54	24	22	27,0	35	36	10	11
50	12	9,0	50	65	33	30	31,0	45	45	12	13
63	16	9,0	52	67	37	35	39,0	50	50	12	15

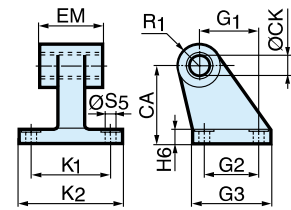

Clevis bracket MP2



Intended for flexible mounting of cylinder. Clevis bracket MP2 can be combined with clevis bracket MP4.

Materials
 Clevis bracket: Surface-treated aluminium, black
 Mounting screws according to DIN 912:
 Zinc-plated steel 8.8
 Pin: surface treated steel

Cyl. bore Ø mm	Weight kg	Order code
32	0,08	P1C-4KMT
40	0,11	P1C-4LMT
50	0,14	P1C-4MMT
63	0,29	P1C-4NMT

Supplied complete with mounting screws for attachment to cylinder.

Ø32-63 according to ISO MP2, VDMA, AFNOR

Cyl. bore mm	E mm	UB h14 mm	CB H14 mm	FL ±0,2 mm	L mm	I2 mm	CD H9 mm	MR mm	XD* mm	XD2* mm
32	45,0	45	26,0	22	13	5,5	10	10	70,5	79,0
40	52,0	52	28,0	25	16	5,5	12	12	75,5	83,5
50	65,0	60	32,0	27	16	6,5	12	12	79,5	86,0
63	75,0	70	40,0	32	21	6,5	16	16	90,0	95,5

S = Stroke length

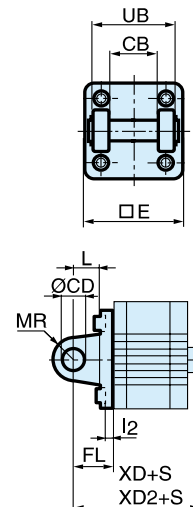

Cylinder mountings

Clevis bracket MP4



Intended for flexible mounting of cylinder. Clevis bracket MP4 can be combined with clevis bracket MP2.

Materials
 Clevis bracket: Surface-treated aluminium, black
 Mounting screws according to DIN 912: Zinc-plated steel 8.8

Supplied complete with mounting screws for attachment to cylinder.

Cyl. bore Ø mm	Weight kg	Order code
32	0,09	P1C-4KME
40	0,13	P1C-4LME
50	0,17	P1C-4MME
63	0,36	P1C-4NME

Ø32-100 according to ISO MP4, VDMA, AFNOR

Cyl. bore mm	E mm	EW mm	FL ±0,2 mm	L mm	I2 mm	CD H9 mm	MR mm	XD* mm	XD2* mm
32	45,0	26,0	22	13	5,5	10	10	70,5	79,0
40	52,0	28,0	25	16	5,5	12	12	75,5	83,5
50	65,0	32,0	27	16	6,5	12	12	79,5	86,0
63	75,0	40,0	32	21	6,5	16	16	90,0	95,5

S = Stroke length

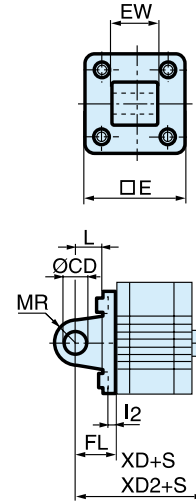

Clevis bracket GA



Intended for flexible mounting of cylinder. Clevis bracket GA can be combined with pivot bracket with swivel bearing, swivel eye bracket and swivel rod eye.

Materials
 Clevis bracket: Surface-treated aluminium, black
 Pin: Surface hardened steel
 Locking pin: Spring steel
 Circlips according to DIN 471: Spring steel
 Mounting screws acc. to DIN 912: Zinc-plated steel 8.8

Supplied complete with mounting screws for attachment to cylinder.

Cyl. bore Ø mm	Weight kg	Order code
32	0,09	P1C-4KMCA
40	0,13	P1C-4LMCA
50	0,17	P1C-4MMCA
63	0,36	P1C-4NMCA

According to VDMA, AFNOR

Cyl. bore mm	E mm	B2 d12 mm	B1 H14 mm	T mm	B3 mm	R2 mm	L1 mm	FL ±0,2 mm	I2 mm	L mm	CN F7 mm	R1 mm	XD* mm	XD2* mm
32	45	34	14	3	3,3	17	11,5	22	5,5	12	10	11	70,5	79,0
40	52	40	16	4	4,3	20	12,0	25	5,5	15	12	13	75,5	83,5
50	65	45	21	4	4,3	22	14,0	27	6,5	17	16	18	79,5	86,0
63	75	51	21	4	4,3	25	14,0	32	6,5	20	16	18	90,0	95,5

S = Stroke length

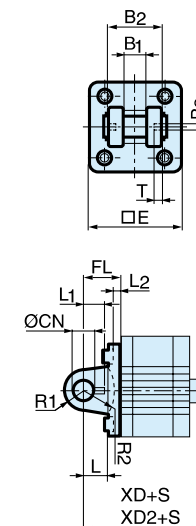

Stainless steel Pin Set GA

Materials
 Pin: Stainless steel
 Locking pin: Stainless steel
 Circlips according to DIN 471: Stainless steel

Cyl. bore Ø mm	Weight kg	Order code
32	0,05	9301054311
40	0,06	9301054312
50	0,07	9301054313
63	0,07	9301054314

Cylinder mountings

Pivot bracket with swivel bearing



Intended for use together with clevis bracket GA.

Material
 Pivot bracket: Surface-treated steel, black
 Swivel bearing according to DIN 648K: Hardened steel

Cyl. bore Ø mm	Weight kg	Order code
32	0,18	P1C-4KMA
40	0,25	P1C-4LMA
50	0,47	P1C-4MMA
63	0,57	P1C-4NMA

According to VDMA, AFNOR

Cyl. bore mm	CN mm	S5 mm	K1 mm	K2 mm	EU mm	G1 mm	G2 mm	EN mm	G3 mm	CH mm	H6 mm	ER mm	Z °
	H7	H13	JS14			JS14 JS14			JS15				
32	10	6,6	38	51	10,5	21	18	14	31	32	10	16	4°
40	12	6,6	41	54	12,0	24	22	16	35	36	10	18	4°
50	16	9,0	50	65	15,0	33	30	21	45	45	12	21	4°
63	16	9,0	52	67	15,0	37	35	21	50	50	12	23	4°

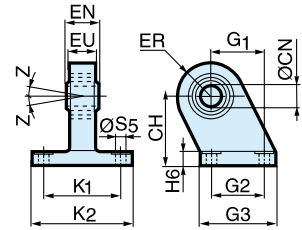

Swivel eye bracket



Intended for use together with clevis bracket GA.

Material
 Bracket: Surface-treated aluminium, black
 Swivel bearing acc. to DIN 648K: Hardened steel

Supplied complete with mounting screws for attachment to cylinder.

Cyl. bore Ø mm	Weight kg	Order code
32	0,08	P1C-4KMSA
40	0,11	P1C-4LMSA
50	0,20	P1C-4MMSA
63	0,27	P1C-4NMSA

According to VDMA, AFNOR

Cyl. bore mm	E mm	B1 mm	B2 mm	EN mm	R1 mm	R2 mm	FL mm	I2 mm	L mm	CN mm	XD* mm	XD2* mm	Z °
32	45	10,5	38	14	16	14	22	5,5	12	10	70,5	79,0	4°
40	52	12,0	44	16	18	16	25	5,5	15	12	75,5	83,5	4°
50	65	15,0	51	21	21	19	27	6,5	15	16	79,5	86,0	4°
63	75	15,0	56	21	23	22	32	6,5	20	16	90,0	95,5	4°

S=Stroke length

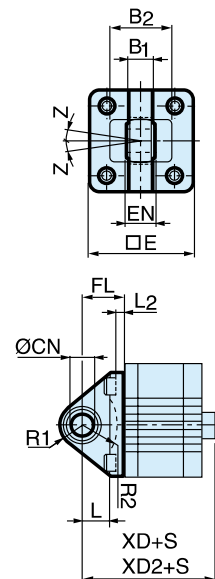

Cylinder mountings

Mounting kit



Mounting kit for back to back mounted cylinders, 3 and 4 position cylinders.

Material:
Mounting: Aluminium
Mounting screws: Zinc-plated steel 8.8

Cyl. bore Ø mm	Weight kg	Order code
32	0,060	P1E-6KB0
40	0,078	P1E-6LB0
50	0,162	P1E-6MB0
63	0,194	P1E-6NB0

Cyl. bore mm	E mm	TG mm	ØFB mm	MF mm	A mm	ØBA mm
32	50	32,5	6,5	5	16	30
40	60	38,0	6,5	5	16	35
50	66	46,5	8,5	6	20	40
63	80	56,5	8,5	6	20	45

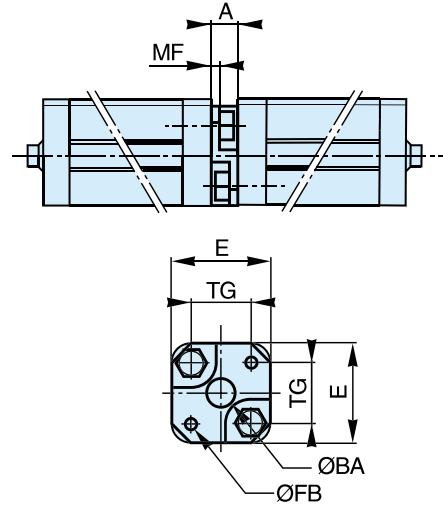

Piston rod mountings

Swivel rod eye



Swivel rod eye for articulated mounting of cylinder. Swivel rod eye can be combined with clevis bracket GA. Maintenance-free.

Materials
 Swivel rod eye: Zinc-plated steel
 Swivel bearing according to DIN 648K: Hardened steel

Cyl. bore Ø mm	Weight kg	Order code
32 / 40	0,08	P1C-4KRS
50 / 63	0,12	P1C-4LRS

Stainless steel swivel rod eye



Stainless-steel swivel rod eye for articulated mounting of cylinder. Swivel rod eye can be combined with clevis bracket GA. Maintenance-free.

Materials
 Swivel rod eye: Stainless steel
 Swivel bearing according to DIN 648K: Stainless steel

Use stainless steel nut with stainless steel swivel rod eye.

Cyl. bore Ø mm	Weight kg	Order code
32 / 40	0,08	P1S-4JRT
50 / 63	0,12	P1S-4LRT

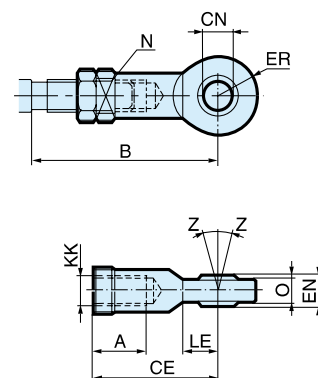

According to ISO 8139

Cyl. bore mm	A mm	B min mm	B max mm	CE mm	CN H9 mm	EN h12 mm	ER mm	KK mm	LE min mm	N mm	O mm	Z 12°
32 / 40	20	48,0	55	43	10	14	14	M10x1,25	15	17	10,5	12°
50 / 63	22	56,0	62	50	12	16	16	M12x1,25	17	19	12,0	12°

Clevis



Clevis for articulated mounting of cylinder.

Material
 Clevis, clip: Galvanized steel
 Pin: Hardened steel

Cyl. bore Ø mm	Weight kg	Order code
32 / 40	0,09	P1C-4KRC
50 / 63	0,15	P1C-4LRC

Stainless steel clevis



Stainless-steel clevis for articulated mounting of cylinder.

Material
 Clevis: Stainless steel
 Pin: Stainless steel
 Circlips according to DIN 471: Stainless steel

Use stainless steel nut with stainless steel swivel rod eye.

Cyl. bore Ø mm	Weight kg	Order code
32 / 40	0,09	P1S-4JRD
50 / 63	0,15	P1S-4LRD

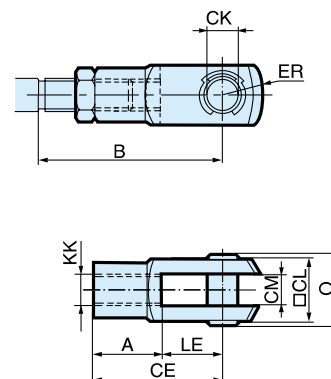

According to ISO 8140

Cyl. bore mm	A mm	B min mm	B max mm	CE mm	CK h11/E9 mm	CL mm	CM mm	ER mm	KK mm	LE mm	O mm
32 / 40	20	45,0	52	40	10	20	10	16	M10x1,25	20	28,0
50 / 63	24	54,0	60	48	12	24	12	19	M12x1,25	24	32,0

Piston rod mountings

Flexo coupling



Flexo coupling for articulated mounting of piston rod. Flexo fitting is intended to take up axial angle errors within a range of ±4°.

Material
Flexo coupling, nut: Zinc-plated steel
Socket: Hardened steel

Supplied complete with galvanized adjustment nut.

Cyl. bore Ø mm	Weight kg	Order code
32 / 40	0,21	P1C-4KRF
50 / 63	0,22	P1C-4LRF

Cyl. bore mm	B min mm	B max mm	DL	EH	EI	EK	EL	EN	EO	EP	EQ	ER	M	Z
				mm	mm	mm	mm	mm	mm	mm	mm	mm	mm	mm
32 / 40	36,0	43	M10x1,25	20	23	70	31	12	30	30	19	30	5,0	4°
50 / 63	37,0	43	M12x1,25	23	23	67	31	12	30	30	19	30	6,0	4°

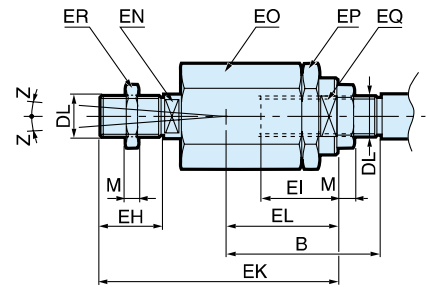

Nut



Intended for fixed mounting of accessories to the piston rod.

Material: Galvanized steel

(Supplied in quantities in multiples of 10 only)

Cyl. bore Ø mm	Weight kg	Order code
32 / 40	0,007	9128985601
50 / 63	0,010	0261109910

Stainless steel nut



Intended for fixed mounting of accessories to the piston rod.

Material: Stainless steel A2

Cyl. bore Ø mm	Weight kg	Order code
32 / 40	0,007	9126725404
50 / 63	0,010	9126725405

According to DIN 439 B

Cyl. bore mm	d	M	S
		mm	mm
32 / 40	M10x1,25	5,0	17
50 / 63	M12x1,25	6,0	19

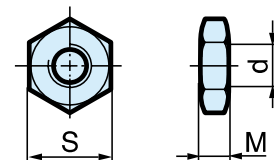

Drop-in sensors

The "drop-in" sensors can easily be installed from the side in the sensor groove, at any position along the piston stroke.

The sensors are completely recessed and thus mechanically protected. Choose between electronic or reed sensors and several cable lengths and 8 mm and M12 connectors.

The same standard sensors are used for all versions.



Electronic sensors

The new electronic sensors are "Solid State", i.e. they have no moving parts at all. They are provided with short-circuit protection and transient protection as standard. The built-in electronics make the sensors suitable for applications with high on and off switching frequency, and where very long service life is required.

Technical data

Design	GMR (Giant Magnetic Resistance) magneto-resistive function
Installation	From side, down into the sensor groove, so-called drop-in
Outputs	PNP, normally open (also available in NPN design, normally closed, on request)
Voltage range	10-30 VDC 10-18 V DC, ATEX sensor
Ripple	max 10%
Voltage drop	max 2,5 V
Load current	max 100 mA
Internal consumption	max 10 mA
Actuating distance	min 9 mm
Hysteresis	max 1,5 mm
Repeatability accuracy	max 0,2 mm
On/off switching frequency	max 5 kHz
On switching time	max 2 ms
Off switching time	max 2 ms
Encapsulation	IP 67 (EN 60529)
Temperature range	-25 °C to +75 °C -20 °C to +45 °C, ATEX sensor
Indication	LED, yellow
Material housing	PA 12
Material screw	Stainless steel
Cable	PVC or PUR 3x0.25 mm ² see order code respectively

Reed sensors

The sensors are based on proven reed switches, which offer reliable function in many applications. Simple installation, a protected position on the cylinder and clear LED indication are important advantages of this range of sensors.

Technical data

Design	Reed element
Mounting	From side, down into the sensor groove, so-called drop-in
Output	Normally open , or normally closed
Voltage range	10-30 V AC/DC or 10-120 V AC/DC 24-230 V AC/DC
Load current	max 500 mA for 10-30 V or max 100 mA for 10-120 V max 30 mA for 24-230 V
Breaking power (resistive)	max 6 W/VA
Actuating distance	min 9 mm
Hysteresis	max 1,5 mm
Repeatability accuracy	0,2 mm
On/off switching frequency	max 400 Hz
On switching time	max 1,5 ms
Off switching time	max 0,5 ms
Encapsulation	IP 67 (EN 60529)
Temperature range	-25 °C to +75 °C
Indication	LED, yellow
Material housing	PA12
Material screw	Stainless steel
Cable	PVC or PUR 3x0.14 mm ² see order code respectively

Electronic sensors

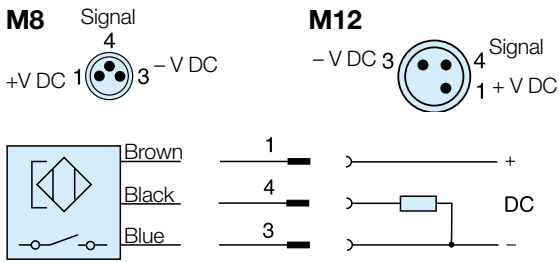

Reed sensors

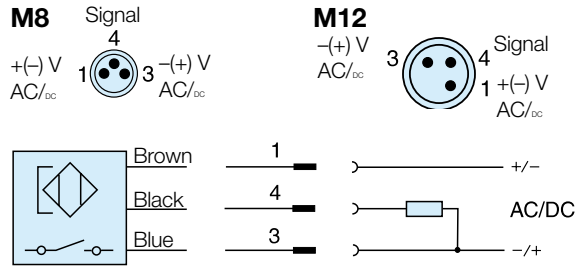

P8S-GCFPX

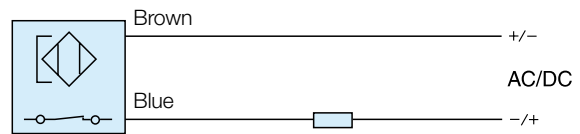

P8S-GRFLX / P8S-GRFLX2

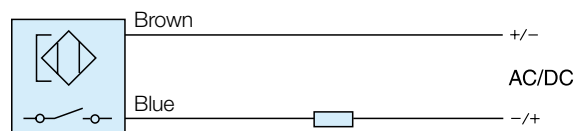

Dimensions

Sensors

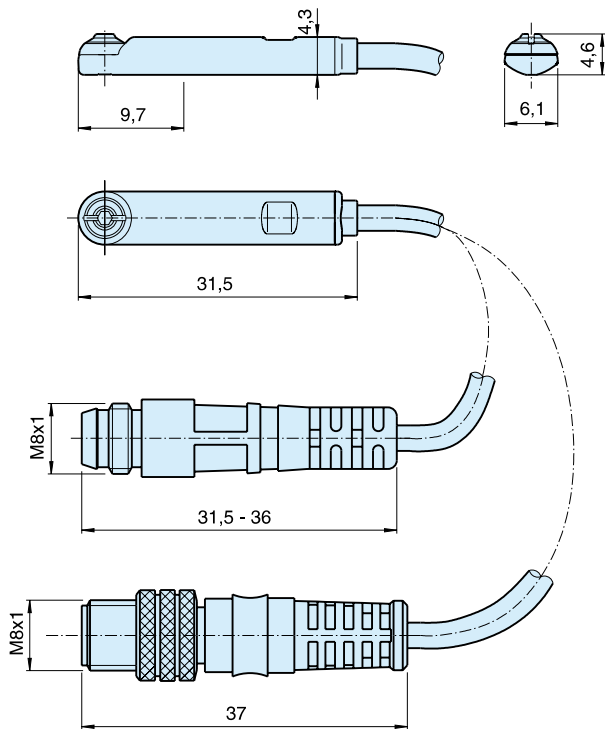

Sensor Installation

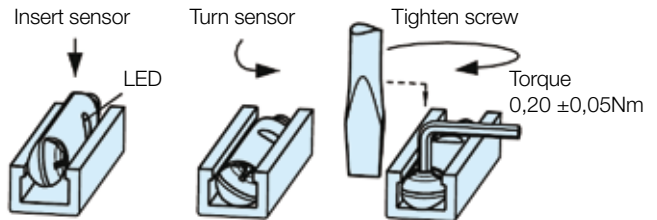

Ordering data

Output/function	Cable/connector	Weight kg	Order code
Electronic sensors , 10-30 V DC			
PNP type, normally open	0,27 m PUR-cable and 8 mm snap-in male connector	0,007	P8S-GPSHX
PNP type, normally open	0,27 m PUR-cable and M12 screw male connector	0,015	P8S-GPMHX
PNP type, normally open	3 m PVC-cable without connector	0,030	P8S-GPFLX
PNP type, normally open	10 m PVC-cable without connector	0,110	P8S-GPFTX
Reed sensors , 10-30 V AC/DC			
Normally open	0,27 m PUR-cable and 8 mm snap-in male connector	0,007	P8S-GSSHX
Normally open	0,27 m PUR-cable and M12 screw male connector	0,015	P8S-GSMHX
Normally open	3 m PVC-cable without connector	0,030	P8S-GSFLX
Normally open	10 m PVC-cable without connector	0,110	P8S-GSFTX
Normally closed	5m PVC-cable without connector ⁽¹⁾	0,050	P8S-GCFPX
Reed sensors, 10-120 V AC/DC			
Normally open	3 m PVC-cable without connector	0,030	P8S-GRFLX
Reed sensorer, 24-230 V AC/DC			
Normalt öppen	3 m PVC-kabel utan kontakt	0,030	P8S-GRFLX2

1) Without LED

Connecting cables with one connector

The cables have an integral snap-in female connector.



Type of cable	Cable/connector	Weight kg	Order code
Cables for sensors, complete with one female connector			
Cable, Flex PVC	3 m 8 mm Snap-in connector	0,07	9126344341
Cable, Flex PVC	10 m 8 mm Snap-in connector	0,21	9126344342
Cable, Polyurethane	3 m 8 mm Snap-in connector	0,01	9126344345
Cable, Polyurethane	10 m 8 mm Snap-in connector	0,20	9126344346
Cable, Polyurethane	5 m M12 screw connector	0,07	9126344348
Cable, Polyurethane	10 m M12 screw connector	0,20	9126344349

Male connectors for connecting cables

Cable connectors for producing your own connecting cables. The connectors can be quickly attached to the cable without special tools. Only the outer sheath of the cable is removed. The connectors are available for M8 and M12 screw connectors and meet protection class IP 65.



Connector	Weight kg	Order code
M8 screw connector	0,017	P8CS0803J
M12 screw connector	0,022	P8CS1204J

Specifying air quality (purity) in accordance with ISO8573-1:2010, the international standard for Compressed Air Quality

ISO8573-1 is the primary document used from the ISO8573 series as it is this document which specifies the amount of contamination allowed in each cubic metre of compressed air.

ISO8573-1 lists the main contaminants as Solid Particulate, Water and Oil. The purity levels for each contaminant are shown separately in tabular form, however for ease of use, this document combines all three contaminants into one easy to use table.

ISO8573-1:2010 CLASS	Solid Particulate				Water		Oil
	Maximum number of particles per m ³			Mass Concentration mg/m ³	Vapour Pressure Dewpoint	Liquid g/m ³	Total Oil (aerosol liquid and vapour) mg/m ³
	0,1 - 0,5 micron	0,5 - 1 micron	1 - 5 micron				
0	As specified by the equipment user or supplier and more stringent than Class 1						
1	≤ 20 000	≤ 400	≤ 10	-	≤ -70 °C	-	0,01
2	≤ 400 000	≤ 6 000	≤ 100	-	≤ -40 °C	-	0,1
3	-	≤ 90 000	≤ 1 000	-	≤ -20 °C	-	1
4	-	-	≤ 10 000	-	≤ +3 °C	-	5
5	-	-	≤ 100 000	-	≤ +7 °C	-	-
6	-	-	-	≤ 5	≤ +10 °C	-	-
7	-	-	-	5 - 10	-	≤ 0,5	-
8	-	-	-	-	-	0,5 - 5	-
9	-	-	-	-	-	5 - 10	-
X	-	-	-	> 10	-	> 10	> 10

Specifying air purity in accordance with ISO8573-1:2010

When specifying the purity of air required, the standard must always be referenced, followed by the purity class selected for each contaminant (a different purity class can be selected for each contamination if required).

An example of how to write an air quality specification is shown below:

ISO 8573-1:2010 Class 1.2.1

ISO 8573-1:2010 refers to the standard document and its revision, the three digits refer to the purity classifications selected for solid particulate, water and total oil. Selecting an air purity class of 1.2.1 would specify the following air quality when operating at the standard's reference conditions :

Class 1 - Particulate

In each cubic metre of compressed air, the particulate count should not exceed 20,000 particles in the 0.1 - 0.5 micron size range, 400 particles in the 0.5 - 1 micron size range and 10 particles in the 1 - 5 micron size range.

Class 2 - Water

A pressure dewpoint (PDP) of -40°C or better is required and no liquid water is allowed.

Class 1 - Oil

In each cubic metre of compressed air, not more than 0.01mg of oil is allowed. This is a total level for liquid oil, oil aerosol and oil vapour.

ISO8573-1:2010 Class zero

- **Class 0 does not mean zero contamination.**
- **Class 0 requires the user and the equipment manufacturer to agree contamination levels as part of a written specification.**
- **The agreed contamination levels for a Class 0 specification should be within the measurement capabilities of the test equipment and test methods shown in ISO8573 Pt 2 to Pt 9.**
- **The agreed Class 0 specification must be written on all documentation to be in accordance with the standard.**
- **Stating Class 0 without the agreed specification is meaningless and not in accordance with the standard.**
- **A number of compressor manufacturers claim that the delivered air from their oil-free compressors is in compliance with Class 0.**
- **If the compressor was tested in clean room conditions, the contamination detected at the outlet will be minimal. Should the same compressor now be installed in typical urban environment, the level of contamination will be dependent upon what is drawn into the compressor intake, rendering the Class 0 claim invalid.**
- **A compressor delivering air to Class 0 will still require purification equipment in both the compressor room and at the point of use for the Class 0 purity to be maintained at the application.**
- **Air for critical applications such as breathing, medical, food, etc typically only requires air quality to Class 2.2.1 or Class 2.1.1.**
- **Purification of air to meet a Class 0 specification is only cost effective if carried out at the point of use.**

Parker Worldwide

Europe, Middle East, Africa

AE – United Arab Emirates,
Dubai

Tel: +971 4 8127100
parker.me@parker.com

AT – Austria, Wiener Neustadt

Tel: +43 (0)2622 23501-0
parker.austria@parker.com

AT – Eastern Europe, Wiener
Neustadt

Tel: +43 (0)2622 23501 900
parker.easteurope@parker.com

AZ – Azerbaijan, Baku

Tel: +994 50 2233 458
parker.azerbaijan@parker.com

BE/LU – Belgium, Nivelles

Tel: +32 (0)67 280 900
parker.belgium@parker.com

BY – Belarus, Minsk

Tel: +375 17 209 9399
parker.belarus@parker.com

CH – Switzerland, Etoy

Tel: +41 (0)21 821 87 00
parker.switzerland@parker.com

CZ – Czech Republic, Klecany

Tel: +420 284 083 111
parker.czechrepublic@parker.com

DE – Germany, Kaarst

Tel: +49 (0)2131 4016 0
parker.germany@parker.com

DK – Denmark, Ballerup

Tel: +45 43 56 04 00
parker.denmark@parker.com

ES – Spain, Madrid

Tel: +34 902 330 001
parker.spain@parker.com

FI – Finland, Vantaa

Tel: +358 (0)20 753 2500
parker.finland@parker.com

FR – France, Contamine s/Arve

Tel: +33 (0)4 50 25 80 25
parker.france@parker.com

GR – Greece, Athens

Tel: +30 210 933 6450
parker.greece@parker.com

HU – Hungary, Budapest

Tel: +36 1 220 4155
parker.hungary@parker.com

IE – Ireland, Dublin

Tel: +353 (0)1 466 6370
parker.ireland@parker.com

IT – Italy, Corsico (MI)

Tel: +39 02 45 19 21
parker.italy@parker.com

KZ – Kazakhstan, Almaty

Tel: +7 7272 505 800
parker.easteurope@parker.com

NL – The Netherlands, Oldenzaal

Tel: +31 (0)541 585 000
parker.nl@parker.com

NO – Norway, Asker

Tel: +47 66 75 34 00
parker.norway@parker.com

PL – Poland, Warsaw

Tel: +48 (0)22 573 24 00
parker.poland@parker.com

PT – Portugal, Leca da Palmeira

Tel: +351 22 999 7360
parker.portugal@parker.com

RO – Romania, Bucharest

Tel: +40 21 252 1382
parker.romania@parker.com

RU – Russia, Moscow

Tel: +7 495 645-2156
parker.russia@parker.com

SE – Sweden, Spånga

Tel: +46 (0)8 59 79 50 00
parker.sweden@parker.com

SK – Slovakia, Banská Bystrica

Tel: +421 484 162 252
parker.slovakia@parker.com

SL – Slovenia, Novo Mesto

Tel: +386 7 337 6650
parker.slovenia@parker.com

TR – Turkey, Istanbul

Tel: +90 216 4997081
parker.turkey@parker.com

UA – Ukraine, Kiev

Tel: +380 44 494 2731
parker.ukraine@parker.com

UK – United Kingdom, Warwick

Tel: +44 (0)1926 317 878
parker.uk@parker.com

ZA – South Africa, Kempton Park

Tel: +27 (0)11 961 0700
parker.southafrica@parker.com

North America

CA – Canada, Milton, Ontario

Tel: +1 905 693 3000

US – USA, Cleveland

Tel: +1 216 896 3000

Asia Pacific

AU – Australia, Castle Hill

Tel: +61 (0)2-9634 7777

CN – China, Shanghai

Tel: +86 21 2899 5000

HK – Hong Kong

Tel: +852 2428 8008

IN – India, Mumbai

Tel: +91 22 6513 7081-85

JP – Japan, Tokyo

Tel: +81 (0)3 6408 3901

KR – South Korea, Seoul

Tel: +82 2 559 0400

MY – Malaysia, Shah Alam

Tel: +60 3 7849 0800

NZ – New Zealand, Mt Wellington

Tel: +64 9 574 1744

SG – Singapore

Tel: +65 6887 6300

TH – Thailand, Bangkok

Tel: +662 186 7000-99

TW – Taiwan, Taipei

Tel: +886 2 2298 8987

South America

AR – Argentina, Buenos Aires

Tel: +54 3327 44 4129

BR – Brazil, Sao Jose dos Campos

Tel: +55 800 727 5374

CL – Chile, Santiago

Tel: +56 2 623 1216

MX – Mexico, Apodaca

Tel: +52 81 8156 6000

European Product Information Centre

Free phone: 00 800 27 27 5374

(from AT, BE, CH, CZ, DE, DK, EE, ES, FI,
FR, IE, IL, IS, IT, LU, MT, NL, NO, PL, PT, RU,
SE, SK, UK, ZA)



Parker Hannifin Ltd.

Tachbrook Park Drive
Tachbrook Park,
Warwick, CV34 6TU
United Kingdom
Tel.: +44 (0) 1926 317 878
Fax: +44 (0) 1926 317 855
parker.uk@parker.com
www.parker.com



www.hccl.ie