

MODELS-1071, 1072, 1073, 1074



Standard Aluminium Case & Brass Internals Test Gauges

APPLICATIONS

The Stewarts test gauge is used for inspection, test and validation of key installation points. An ideal choice for satisfying pressure measurement when highly-reliable precision is needed.

STANDARD SPECIFICATION

Standard Test Gauge with Aluminium Case & Brass Internals
(Weatherproof construction to IP54)

Sizes

150 and 250mm

Case/ Bezel

Aluminium. Stove Enamelled

Socket & Element

Brass, Phosphor Bronze or Beryllium Copper

Movement

Brass

Blowout Protection

Blow-out device (EN 837-1 S1)

Dial

White Anodised Aluminium (Black Printing)

Pointer

Black Aluminium (Knife Edge)

Window

Sheet Glass

Traceability

All instruments are individually calibrated and have an unique Serial Number. Calibration Certificates are issued for each gauge

Certification available on request

- Certificate of Conformity Traceable to National Standards
- Group Certification (Pressure Test Calibration Statement)

For (316ss & Monel) only

Safety

All units are manufactured to comply with EN 837-1, S1 Blowout device specification and other regulatory standards including PED 2014/68/EU.

Installation instructions

Refer to EN 837-2 and our [Guidance On Use of Equipment](#) data sheet.

Accuracy class

	ACCURACY CLASS EN837-1 (Optional)			Higher Pressure
	0 - 600 bar	>600 - 1600 bar	>1600 - 2500 bar	
150mm	0.25 (0.6)	0.25 (0.6)	0.6 (0.25)	
250mm	0.25 (0.6)	0.25 (0.6)	0.6 (0.25)	

0.5% Accuracy on request (Consult Sales)

Higher Ranges on request (Consult Sales)

Over 1600 bar on rising pressure only

Over-pressure

0 - 100 bar	>100 - 600 bar	>600 - 1600 bar	>1600 - 2500 bar
1.25 x FSD	1.15 x FSD	1.10 x FSD	1.10 x FSD

Scale Range

150 & 250mm gauges vacuum to 2500 bar

Or other equivalent units of pressure or vacuum

PED 97/23/EC limits, GAS Group.1 <1000 bar, GAS Group.2 <3000 bar

Pressure Connection Thread

1/8", 1/4", 3/8", 1/2" NPT, BSP, BSPT (See High Pressure Options)

	BRASS MAX PRESSURE EN 837-1		
THREAD EN837	NPT (316ss / Monel)	BSP (316ss / Monel)	BSPT (316ss / Monel)
1/8"	400 (400 bar)	400 (400 bar)	600 (1000 bar)
1/4"	600 (1000 bar)	600 (1000 bar)	600 (1000 bar)
3/8"	600 (1000 bar)	600 (1000 bar)	600 (1000 bar)
1/2"	600 (1000 bar)	600 (1000 bar)	600 (1000 bar)

Model-1072 Direct Mounted



- Model-1071 Surface Mounted (Bottom Connection)
 - Model-1072 Direct Mounted (Bottom Connection)
 - Model-1073 Flush Mounted Screw Fixing (Rear Connection)
 - Model-1074 Flush Mounted Clamp Fixing (Rear Connection)
- [See Page-2 for dimension](#)

Operating Temperature Range EN837

-20° to 60°C (-4°F to 140°F)

[Options for lower/higher operating ranges \(Contact Sales\)](#)

Temperature Error

Additional error when temperature changes from reference

Temperature of 20°C (68°F) ±0.4% for every 10°C (18°F) rising or Falling % of span

Optional Extras

- 316 Stainless Steel wetted parts
- Monel according to ISO 15156 / NACE MR-01-75 wetted parts
- Optional dial materials & Custom markings
- Other pressure connections (including high pressure)
- Perspex window
- Laminated Safety Glass
- Orifice Restrictor Screw (standard Ø0.9mm, Ø0.4mm on request)
- Customer logo printed on dial
- Gauge over-pressure up to 130% of FSD
- Safety Pattern Type with Baffle wall, EN837-1, S3 (Dimensions available on request)
- Steel case EN837-1 S1 construction (painted black)

[Further options on request](#)

Available with a wide range of accessories

Syphons, Snubbers, Overrange gauge protectors, Valves, Manifolds, Diaphragm seals, Swivel adaptors, etc ensures that STEWARTS can provide you with the right product to suit any individual application or requirement.

GAUGE	HIGH PRESSURE THREAD OPTIONS (Up to 2500 bar) 316 s.s / Monel					
	TUBE MP (Up to 20 ksi)			TUBE HP (Up to 36 ksi)		
	1/4	3/8	9/16	1/4	3/8	9/16
150mm	M	M	M	M/F	M	M
250mm	M/F	M/F	M	M/F	M	M

Ordering Parameters, Please state the following: SIZE, MODEL NO, SCALE RANGE, CONNECTION, PRESSURE MEDIUM & OPTIONAL EXTRAS

MODELS-1071, 1072, 1073, 1074

Aluminium Case & Brass Internals Test Gauges

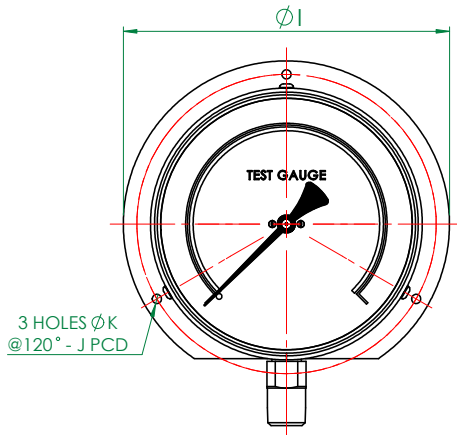

MODEL - 1071
Surface Mounted

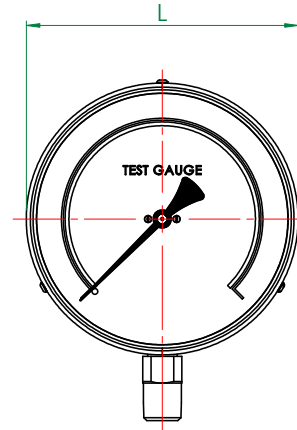
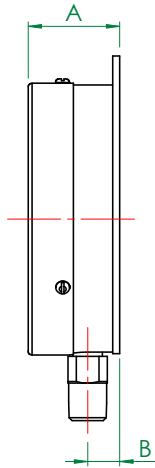

MODEL - 1072
Direct Mounted (Standard)

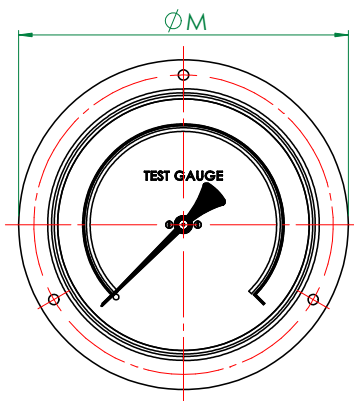
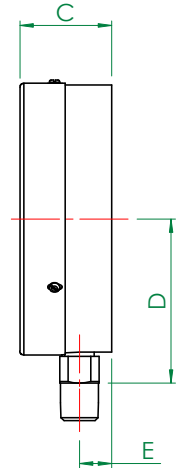

MODEL - 1073
Flush Mounted Screw Fixing

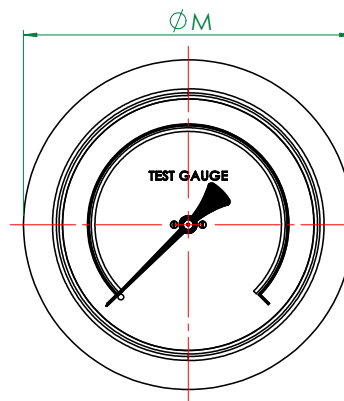
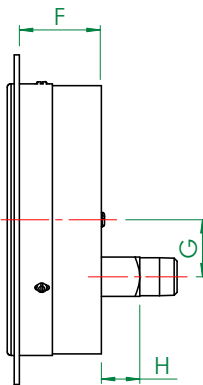

MODEL - 1074
Flush Mounted - Clamp Fixing

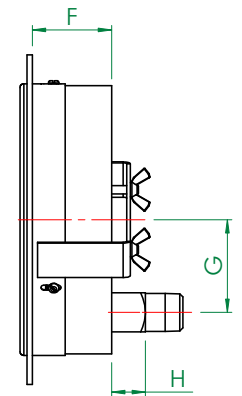

General Arrangement Dimensions in mm, tol' ± 1mm

Dim	A	B	C	D	E	F	G	H	I	J	K	L	M	PANEL CUT OUT
Dial Ø 6" (150mm)	50	19	45	93	14	39	32	18.5	178	168	5	152	185	165
10" (250mm)	55	17	55	148	17	49	52	16	290	273	6.5	256	302	270

STEWART-BUCHANAN GAUGES LTD

Sales Office & Manufacturing Facility - 7 Garrell Road, Burnside Industrial Estate, Kilsyth, Glasgow G65 9JX, SCOTLAND
Tel: +44 (0)1236 821533 | Fax: +44 (0)1236 824090 | E-mail: sales@stewarts-group.com | Web: stewarts-group.com

DATA SHEET REF: 107-REV01-15



HANLEY CONTROLS

CLONMEL

www.hccl.ie