

MODELS-1071S, 1072S, 1073S, 1074S



All stainless steel construction Test Gauges

APPLICATIONS

The Stewarts test gauge is used for inspection, test and validation of key installation points. An ideal choice for satisfying pressure measurement when highly-reliable precision is needed.

STANDARD SPECIFICATION

All Stainless Steel Test Gauge
(150mm Weatherproof Construction to IP66) (250mm to IP54)

Sizes

150 and 250mm

Case/ Bezel

304 Stainless Steel (316 Stainless Steel can be supplied on request)

Socket & Element

316 Stainless Steel

Movement

Stainless Steel Construction

Blowout Protection

Blow-out device (EN 837-1 S1)

Dial

White Anodised Aluminium (Black Printing)

Pointer

Black Aluminium (Knife edge)

Window

Sheet Glass

Traceability

All instruments are individually calibrated and have an unique Serial Number. Calibration Certificates are issued for each gauge

Certification available on request

- Certificate of Conformity Traceable to National Standards
- Group Certification (Pressure Test Calibration Statement)
- BS EN 10204 3.1 Material Certification

Safety

All units are manufactured to comply with EN 837-1, S1 Blowout device specification and other regulatory standards including PED 2014/68/EU.

Installation instructions

Refer to EN 837-2 and our [Guidance On Use of Equipment](#) data sheet.

Accuracy class

	ACCURACY CLASS EN837-1 (Optional)		Higher Pressure
	0 - 600 bar	>600 - 1600 bar	>1600 - 2500 bar
150mm	0.25 (0.6)	0.25 (0.6)	0.6 (0.25)
250mm	0.25 (0.6)	0.25 (0.6)	0.6 (0.25)

0.5% Accuracy on request (Consult Sales)

Higher Ranges on request (Consult Sales)

Over 1600 bar on rising pressure only

Over-pressure

0 - 100 bar	>100 - 600 bar	>600 - 1600 bar	>1600 - 2500 bar
1.25 x FSD	1.15 x FSD	1.10 x FSD	1.10 x FSD

Scale Range

150 & 250mm gauges vacuum to 2500 bar

Or other equivalent units of pressure or vacuum

PED 97/23/EC limits, GAS Group.1 <1000 bar, GAS Group.2 <3000 bar

Pressure Connection Thread

1/8", 1/4", 3/8", 1/2" NPT, BSP, BSPT (See High Pressure Options)

MAX PRESSURE EN 837-1			
THREAD EN837	NPT (316ss / Monel)	BSP (316ss / Monel)	BSPT (316ss / Monel)
1/8"	400 bar	400 bar	400 bar
1/4"	1000 bar	1000 bar	1000 bar
3/8"	1000 bar	1000 bar	1000 bar
1/2"	1000 bar	1600 bar	1000 bar

Ordering Parameters, Please state the following: SIZE, MODEL NO, SCALE RANGE, CONNECTION, PRESSURE MEDIUM & OPTIONAL EXTRAS

DATA SHEET REF: 107S-REV01-15

Specifications and dimensions in this leaflet, are subject to change without prior notice.

Model-1072S Direct Mounted



Model-1071s Surface Mounted (Bottom Connection)

Model-1072s Direct Mounted (Bottom Connection)

Model-1073s Flush Mounted Screw Fixing (Rear Connection)

Model-1074s Flush Mounted Clamp Fixing (Rear Connection)

See Page-2 for dimension

Operating Temperature Range EN837

-20° to 60°C (-4°F to 140°F)

Options for lower/higher operating ranges (Contact Sales)

Temperature Error

Additional error when temperature changes from reference

Temperature of 20°C (68°F) ±0.4% for every 10°C (18°F) rising or Falling % of span

Optional Extras

- Optional dial materials & Custom markings
- Monel according to ISO 15156 / NACE MR-01-75 wetted parts
- Other pressure connections (Including high pressure)
- Laminated safety glass / Perspex window
- Orifice Restrictor Screw (standard Ø0.9mm, Ø0.4mm on request)
- Customer logo printed on dial
- Gauge over-pressure up to 130% of FSD
- Safety Pattern Type with Baffle wall, EN837-1, S3 (Dimensions available on request)

Further options on request

Available with a wide range of accessories

Syphons, Snubbers, Overrange gauge protectors, Valves, Manifolds, Diaphragm seals, Swivel adaptors, etc ensures that STEWARTS can provide you with the right product to suit any individual application or requirement.

High Pressure Options Available

GAUGE	HIGH PRESSURE THREAD OPTIONS (Up to 2500 bar)					
	TUBE MP (Up to 20 ksi)			TUBE HP (Up to 36 ksi)		
	1/4"	3/8"	9/16"	1/4"	3/8"	9/16"
150mm	M	M	M	M/F	M	M
250mm	M/F	M/F	M	M/F	M	M

MODELS-1071S, 1072S, 1073S, 1074S

All stainless steel construction Test Gauges

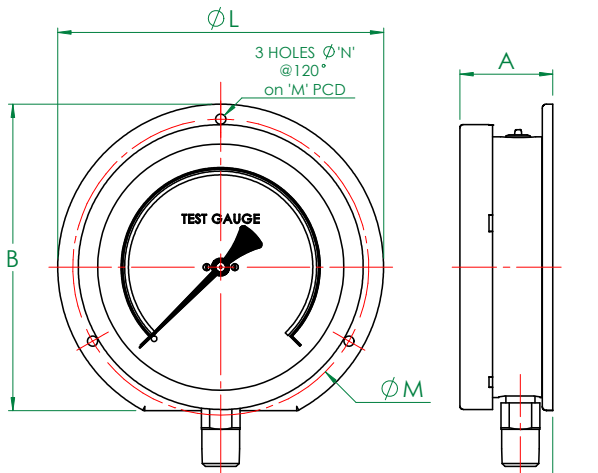

MODEL - 1071/S
Surface Mounted

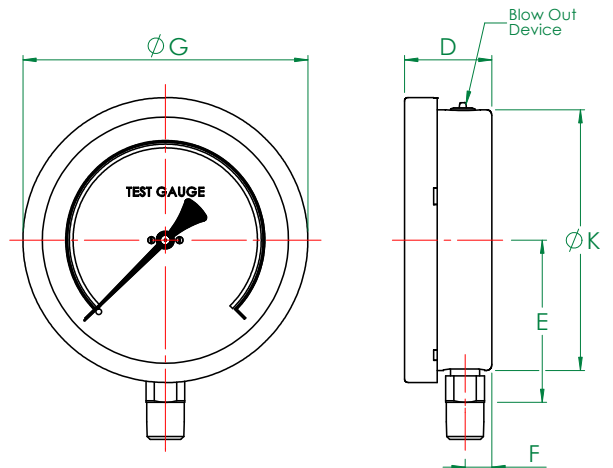

MODEL - 1072/S
Direct Mounted (Standard)

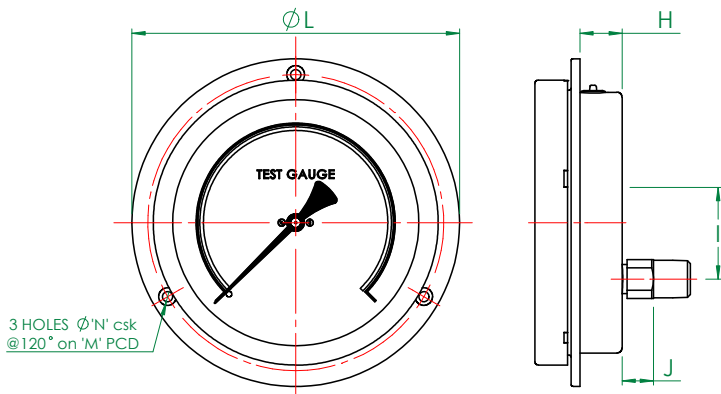

MODEL - 1073/S
Flush Mounted Screw Fixing

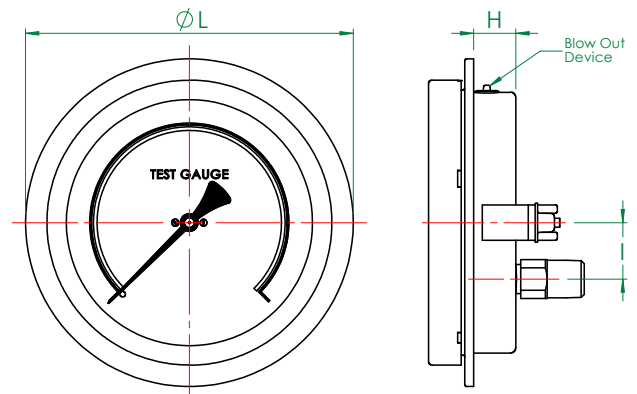

MODEL - 1074/S
Flush Mounted - Clamp Fixing

General Arrangement Dimensions in mm, tol' ± 1mm

Dim	A	B	C	D	E	F	G	H	I	J	K	L	M	N	O	PANEL CUT OUT
Dial Ø																
6" (150mm)	50.5	174	17	48.5	93	15	162	24.5	32	18	148	185	168	5	5.8	153
10" (250mm)	51.5	*294	19	51.5	148	19	252	43.5	52	16	248	302	273	6.5	6.35	270

* Mounting lugs are used instead of surface flange.

STEWART-BUCHANAN GAUGES LTD

Sales Office & Manufacturing Facility - 7 Garrell Road, Burnside Industrial Estate, Kilsyth, Glasgow G65 9JX, SCOTLAND
Tel: +44 (0)1236 821533 | Fax: +44 (0)1236 824090 | E-mail: sales@stewarts-group.com | Web: stewarts-group.com

DATA SHEET REF: 107s-REV01-15



HANLEY CONTROLS

CLONMEL

www.hccl.ie