

COMMUNICATING CARBON DIOXIDE DETECTORS

Measures CO₂, Humidity, Temperature, Temperature Set Point, and Override

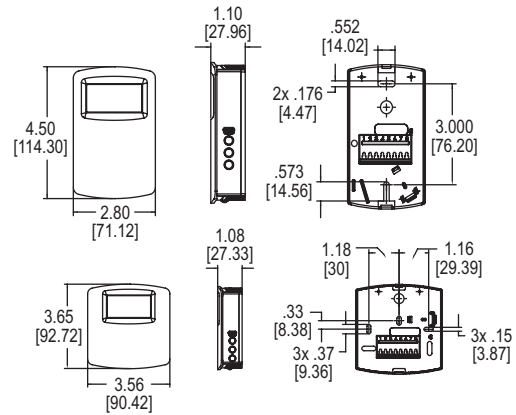

www.hccl.ie



The **Series CDTA Communicating Carbon Dioxide Detectors** combine the function of three room sensors into a single, compact housing. Parameters include carbon dioxide, humidity, temperature, and temperature set point with override. By having field selectable Modbus® and BACnet Communications, only four wires are needed for power and the communication signal. The communicating detectors can be daisy chained together to further reduce installation cost. In order to reduce the set up time, the RS-485 MAC address is set up using on board dip switches. A second set of dip switches are used to select whether output is Modbus® RTU or BACnet MS/TP communication protocols and to limit access to the set up menu.

Like our Series CDT Carbon Dioxide Transmitter, the Series CDTA uses a Single Beam Dual Wavelength Non-Dispersive Infrared (NDIR) sensor to measure the carbon dioxide level. This technology can be used in installations that will be occupied 24 hours per day. For improved accuracy, the transmitter can be field calibrated to the environmental conditions of the installation. Also, the barometric pressure can be programmed to correct for altitude. The humidity uses a capacitive polymer sensor and the temperature is measured using a 10KΩ thermistor sensor. The humidity sensor is field replaceable without the need for additional calibration.

Optional local and remote displays are available to display any of the parameters. For applications in which the building occupants aren't familiar with CO₂ concentrations, the LCD can be programmed to display temperature, humidity, or temperature set point instead.

FEATURES/BENEFITS

- Digital Intelligent Temperature Compensation Algorithm (DITCA) corrects for errors due to self heating effects of combination wall sensors
- Field selectable Modbus® and BACnet communications reduces wiring
- Single beam dual wavelength CO₂ sensor
- Replaceable humidity/temperature sensor
- Physical hardware lockout
- Optional remote display tool

APPLICATIONS

- Demand control ventilation in schools, office buildings, hospitals, and other indoor environments
- LEED® certification

MODEL CHART			
Model	CO ₂ Concentration	Housing Style	Display
CDTA-2N000	2000 PPM	North American	No
CDTA-2N000-LCD	2000 PPM	North American	Yes
CDTA-2E000	2000 PPM	European	No
CDTA-2E000-LCD	2000 PPM	European	Yes
CDTA-5N000	5000 PPM	North American	No
CDTA-5N000-LCD	5000 PPM	North American	Yes
CDTA-5E000	5000 PPM	European	No
CDTA-5E000-LCD	5000 PPM	European	Yes

OPTIONS	
To order add suffix:	Description
-FC	Factory calibration certificate
Example: CDTA-2N000-FC	

SPECIFICATIONS

Sensor (CO₂): Single beam, dual wavelength NDIR; Humidity: Capacitive polymer; Temperature: 10K Ω thermistor.
Range: CO₂: 0 to 2000 or 5000 PPM CO₂ (depending on model); Humidity: 0 to 100% RH; Temperature: 32 to 122°F (0 to 50°C).
Accuracy: CO₂: ±40 PPM ±3% of reading; RH: ±2% (10 to 90% RH); Temperature: ±1°C @ 25°C.
Temperature Dependence (CO₂): ±8 PPM / °C at 1100 PPM.
Non-Linearity (CO₂): 16 PPM.
Pressure Dependence (CO₂): 0.13% of reading per mm of Hg.
Response Time (CO₂): 2 min= for 99% step change.
Temperature Limits: 32 to 122°F (0 to 50°C).
Humidity Limits: 10 to 95% RH (non-condensing).
Power Requirements: 10-42 VDC / 10-30 VAC.
Power Consumption: Average: 0.5 w; Peak: 1.2 w.
Output: 2-wire RS-485, Modbus® RTU or BACnet MS/TP communication protocol.
Weight: 4.4 oz (125 g).
Enclosure Rating: IP20.
Agency Approvals: BTL, CE.

ACCESSORIES	
Model	Description
GCK-200CO-2000CO2	Calibration gas kit includes a 99.99% nitrogen gas cylinder for calibrating the zero point and a 200 PPM CO / 2000 PPM CO ₂ gas cylinder for calibrating the span point on Dwyer's gas sensing transmitters
A-449	Remote LCD display allows remote indication of select Dwyer® wall mount transmitters for validation or certification purposes
A-CDT-KIT	Accessory kit including terminal block and power supply



LEED® is a registered trademark of the U.S. Green Building Council.
Modbus® is a registered trademark of Schneider Automation, Inc.