

# Compression Fittings

**Brass Compression Fittings**

**Stainless Steel Compression Fittings**

**PL Nickel-Plated Brass Spigot Fittings**



**HANLEY CONTROLS**

CLONMEL

[www.hccl.ie](http://www.hccl.ie)



**HANLEY CONTROLS**

C L O N M E L

[www.hccl.ie](http://www.hccl.ie)

# Compression Fittings

## Brass Compression Fittings (P. 5-5)



**Fluids:** compressed air, non-corrosive industrial fluids  
**Materials:** forged or machined brass  
**Pressure:** 550 bar  
**Temperature:** -60°C to +250°C  
**Ø metric:** 4 mm to 28 mm

## Stainless Steel Compression Fittings (P. 5-31)



**Fluids:** compressed air, coolants, industrial and corrosive fluids  
**Materials:** 316L stainless steel  
**Pressure:** 400 bar  
**Temperature:** -60°C to +250°C  
**Ø metric:** 6 mm to 16 mm

## PL Nickel-Plated Brass Spigot Fittings (P. 5-41)



**Fluids:** compressed air, compatible industrial fluids  
**Materials:** forged or machined nickel-plated brass  
**Pressure:** 18 bar  
**Temperature:** -40°C to +100°C  
**Ø metric:** 4 mm to 14 mm

## Compression Fitting Part Numbers

**0105 14 27 99**

Item Type		Thread	Suffix
01XX: brass	Ø	10 = 1/8	39: bonded seal
18XX: stainless steel		13 = 1/4	40: treated steel
		...	60: nut
	04 = 4 mm	21 = 1/2	70: polymer nut
	06 = 6 mm	27 = 3/4	99: chemical nickel
	...		
	20 = 20 mm		
	28 = 28 mm		

## PL Fitting Part Numbers

**F3BPL 8/10 -1/4**

Item Type		Thread
FBPL	Ø	BSPT:
F3BPL		1/8
HBPL		1/4
WBPL		3/8
...		...
	2.7/4	Metric:
	4/6	M10
	6/8	M12
	7.5/10	
	8/10	
	10/12	
	11/14	

NPT: with adaptor  
BSPT and NPT

### Related Products

Parker also offers another type of brass compression fitting: **Metroluk**, with a one-piece olive/nut. Do not hesitate to contact us.



# Brass Compression Fitting Range

## Brass Fittings

### Stud Fittings

- |                                 |                                |   |                                      |                                    |                                  |                                  |                                 |
|---------------------------------|--------------------------------|---|--------------------------------------|------------------------------------|----------------------------------|----------------------------------|---------------------------------|
| <b>0105</b><br>BSPT<br>Page 5-9 | <b>0105</b><br>NPT<br>Page 5-9 | <b>0101</b><br>BSPP/Metric<br>Page 5-10 | <b>0101..39</b><br>BSPP<br>Page 5-10 | <b>0101</b><br>Metric<br>Page 5-11 | <b>0114</b><br>BSPP<br>Page 5-11 | <b>0109</b><br>BSPT<br>Page 5-12 | <b>0109</b><br>NPT<br>Page 5-12 |
|---------------------------------|--------------------------------|---|--------------------------------------|------------------------------------|----------------------------------|----------------------------------|---------------------------------|



- |                                  |                                  |                                  |                                  |                                      |                                  |                                      |
|----------------------------------|----------------------------------|----------------------------------|----------------------------------|--------------------------------------|----------------------------------|--------------------------------------|
| <b>0199</b><br>BSPP<br>Page 5-12 | <b>0108</b><br>BSPT<br>Page 5-13 | <b>0103</b><br>BSPT<br>Page 5-13 | <b>0118</b><br>BSPP<br>Page 5-14 | <b>0118..39</b><br>BSPP<br>Page 5-14 | <b>0119</b><br>BSPP<br>Page 5-15 | <b>0119..39</b><br>BSPP<br>Page 5-15 |
|----------------------------------|----------------------------------|----------------------------------|----------------------------------|--------------------------------------|----------------------------------|--------------------------------------|



### Tube-to-Tube Fittings

- |                          |                          |                          |                          |                          |                          |                          |
|--------------------------|--------------------------|--------------------------|--------------------------|--------------------------|--------------------------|--------------------------|
| <b>0106</b><br>Page 5-15 | <b>0113</b><br>Page 5-16 | <b>0116</b><br>Page 5-16 | <b>0102</b><br>Page 5-16 | <b>0104</b><br>Page 5-17 | <b>0142</b><br>Page 5-17 | <b>0107</b><br>Page 5-17 |
|--------------------------|--------------------------|--------------------------|--------------------------|--------------------------|--------------------------|--------------------------|



### Complementary Fittings

- |                          |                          |                              |                          |                          |                              |                              |                              |
|--------------------------|--------------------------|------------------------------|--------------------------|--------------------------|------------------------------|------------------------------|------------------------------|
| <b>0166</b><br>Page 5-20 | <b>0124</b><br>Page 5-21 | <b>0124..40</b><br>Page 5-21 | <b>0111</b><br>Page 5-21 | <b>0110</b><br>Page 5-22 | <b>0110..40</b><br>Page 5-22 | <b>0110..60</b><br>Page 5-22 | <b>0110..70</b><br>Page 5-22 |
|--------------------------|--------------------------|------------------------------|--------------------------|--------------------------|------------------------------|------------------------------|------------------------------|



## Self-Fastening Hose Barb Connectors

- |                          |                              |                          |
|--------------------------|------------------------------|--------------------------|
| <b>0132</b><br>Page 5-25 | <b>0133..39</b><br>Page 5-25 | <b>0134</b><br>Page 5-25 |
|--------------------------|------------------------------|--------------------------|



## Accessories

- |                          |                          |                          |                          |                          |                              |                          |                          |                              |                              |                              |
|--------------------------|--------------------------|--------------------------|--------------------------|--------------------------|------------------------------|--------------------------|--------------------------|------------------------------|------------------------------|------------------------------|
| <b>0122</b><br>Page 5-26 | <b>0165</b><br>Page 5-26 | <b>0126</b><br>Page 5-27 | <b>0125</b><br>Page 5-27 | <b>0220</b><br>Page 5-27 | <b>0220..39</b><br>Page 5-27 | <b>0120</b><br>Page 5-28 | <b>0112</b><br>Page 5-28 | <b>0128..39</b><br>Page 5-29 | <b>0151..39</b><br>Page 5-29 | <b>0168..39</b><br>Page 5-29 |
|--------------------------|--------------------------|--------------------------|--------------------------|--------------------------|------------------------------|--------------------------|--------------------------|------------------------------|------------------------------|------------------------------|



- |                          |
|--------------------------|
| <b>0127</b><br>Page 5-30 |
|--------------------------|



# Brass Compression Fittings

These **"universal"** fittings provide users with **numerous connection** options for a wide variety of tube materials without the need for tube threading or soldering. This range **guarantees** excellent long-term sealing and performance.

## Product Advantages

### Simple to Install and Use

- Suitable for pneumatic and medium pressure hydraulic applications
- Compatible with many industrial fluids
- Large product range: 22 configurations
- Excellent sealing due to the tightening of the olive onto the tube
- Metallic sealing guarantees maximum service life
- High strength brass for increased mechanical reliability

### Wide Variety of Tubing

- Connection of different types of tubing and hose: metal, polymer, steel, rubber, etc.
- Multiple tube diameters can be connected using the Parker Legris reducer assembly system
- No insert required for rigid and semi-rigid polyamide tubing below 14 mm



- Applications**
- Pneumatics
  - Cooling
  - Automotive Process
  - Lubrication
  - Fluid Transmission
  - Packaging
  - Industrial Machinery

## Technical Characteristics

<b>Compatible Fluids</b>	Water, machining oil, fuel, hydraulic oil, compressed air, chemical fluids, disinfectants
<b>Working Pressure</b>	Vacuum to 550 bar
<b>Working Temperature</b>	-60°C to +250°C without sealing washer, with metal tubing
<b>Tightening Torque</b>	See "Technical Characteristics" on opposite page

### Component Materials

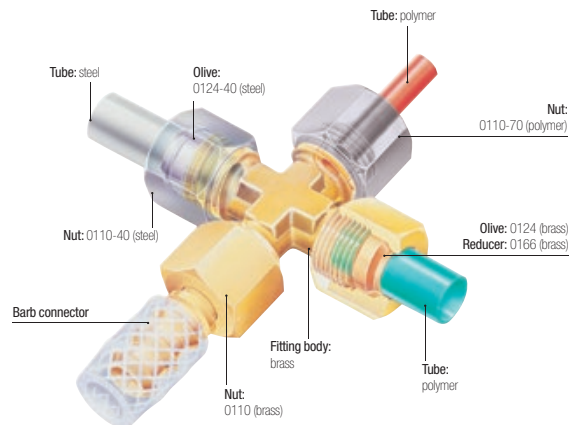

Working temperature: -20°C to +100°C, with sealing washer and polyamide tubing. Reliable performance is dependent upon the type of fluid conveyed, component materials and tubing being used. Guaranteed for use with a vacuum of 755 mm Hg (99% vacuum). Thread sealing must be guaranteed by user.

### Maximum Bore Diameters

The table below shows the recommended compatibility of tube size, BSPP male thread and maximum bore.

Tube O.D.	BSPP Thread	Max. Bore
4-5-6	G1/8	4
6-8-10	G1/4	7
10-12-14	G3/8	11
14-15-16-18	G1/2	14
18-20-22	G3/4	18
22-25-28	G1	24

### Tube Length for Assembly

Minimum length of tube (L) between 2 fittings.









ØD	L (mm)	ØD	L (mm)	ØD	L (mm)
4	26.5	12	39	20	51
5	26	14	41	22	54
6	26	15	41	25	62
8	32	16	46.5	28	62
10	39	18	49.5		

### Regulations

- CNOMO:** E07.21.115N (for robotic equipment in the automotive industry)
- DI:** 97/23/EC (PED)
- RG:** 1907/2006 (REACH)
- DI:** 2002/95/EC (RoHS)
- DI:** 94/9/EC (ATEX)

# Technical Characteristics

## Installing Compression Fittings

Cutting the Tube	Preparing the Connection	Connecting the Tube	Final Assembly
 <p>Cut the polymer or metal tube square.</p>	 <p>For metal tubing, de-burr the tube prior to connection. Tube bending should be done before connection.</p>	 <p>Push the tube up against the shoulder of the body of the fitting and hand tighten.</p>	 <p>Tighten the nut using a spanner or torque wrench to enable the olive to bite on the tube, the connection being completed when the recommended tightening torque is reached (see tables below).</p>
	 <p>Slide the nut onto the tube; lubricate the threads on the body and nut along with the olive to facilitate tightening (for metal tubing as well). Fit the olive onto the end of the tube.</p>		 <p>It is recommended to use an insert in order to prevent tube creeping (diameter &gt; 14mm)</p>

## Recommended Nut Tightening Torque

**Tightening torque in daN.m =** maximum tightening torque of a 0110 nut and 0124 olive with copper, brass or steel tube.

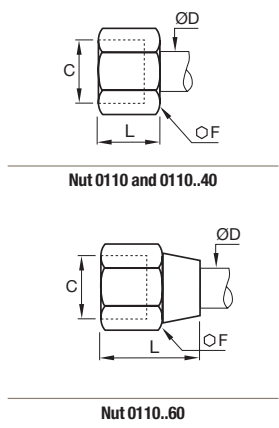

Ø D (mm)	Ø F 0110	Ø F 0110.60	Max. daN.m Copper or Brass	Ø F 0110.40	Max. daN.m Steel
4	10	11	0.7	10	1.5
5	12	13	0.7	12	1.5
6	13	13	1.5	13	2.5
8	14	16	1.5	14	2.5
10	19	20	1.8	19	3
12	22	22	3	22	4.5
14	24	24	3.5	24	5.5
15	24	24	4	24	6
16	27	27	5	27	7
18	30	30	6	30	9
20	32	32	6	32	10
22	36	36	7	36	12
25	41	41	8	41	13
28	42		9		

## Customised Fittings

Working directly with its customers and based on its knowledge and experience, Parker Legris can design customised brass compression fittings for specific requirements using the customer's specifications.

The range of compression fittings also offers nickel chemical surface treatment in order to improve the corrosion resistance and chemical compatibility of the fittings (the model number of the fitting is then given the suffix 99).

The above recommendations are given in good faith. However, since each application is different, it is advisable to undertake tests in actual working conditions.



# Technical Characteristics

The use of Parker Legris brass compression fittings is dependant on the tube material. Tables of recommended working pressure for the different tubes are shown below.

## Recommended Tube Type

**Copper tube:** copper which has been "cold rolled", cold drawn and in straight lengths.  
**Brass tube:** in cold-rolled straight lengths (same working pressure as for copper tube).  
**"Coiled annealed" copper tube:** reduces working pressure by 35%; must be avoided completely if vibration is present.

**Steel tube:** "thin wall" cold drawn, seamless, bright annealed and in straight lengths.  
 6 mm to 16 mm O.D.: max. wall thickness 1 mm  
 Above 16 mm O.D.: max. wall thickness 1.5 mm

**Polyamide tube:** semi-rigid  
 For rigid polyamide tube, multiply the figures in this table by 1.8.

## Recommended Tube-Fitting Assembly Configurations

Assembled using Parker Legris brass olive and nut.

Assembled using Parker Legris steel olive and nut (nut type 0110..40).

Assembled using Parker Legris brass olive and nut.

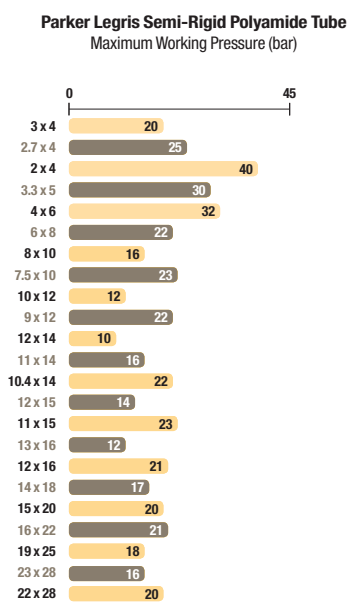
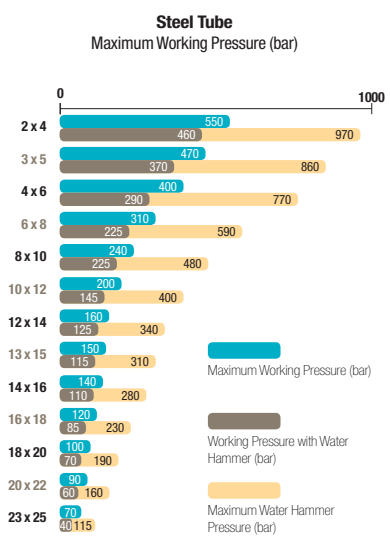
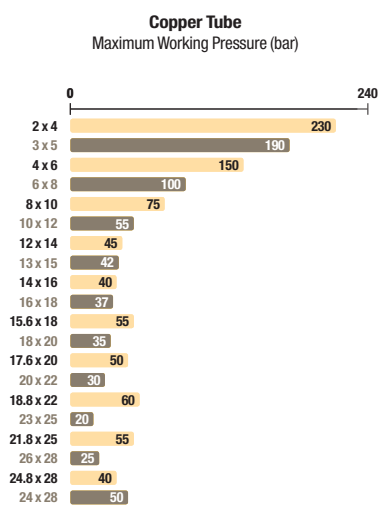

When using a plastic nut type 0110..70, the maximum working pressure is 10 bar, for all diameters.

## Working Pressure Coefficients for Semi-Rigid Polyamide Tubing

Temperature °C	-40°C / -15°C	-15°C / +30°C	+30°C / +50°C	+50°C / +70°C	+70°C / +100°C
Factor	1.8	1	0.68	0.55	0.31

Parker Legris brass compression fittings are not compatible with ammonia and its derivatives.

The above recommendations are given in good faith. However, since each application is different, it is advisable to undertake tests in actual working conditions.

# Brass Compression Fittings

## 0105 Stud Fitting, Male BSPT Thread

Brass

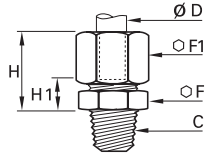

ØD	C		F	F1	H <sub>max</sub>	H1	Kg
4	R1/8	0105 04 10	10	10	17	7	0.012
5	R1/8	0105 05 10	11	12	17.5	7.5	0.016
	R1/4	0105 05 13	14	12	17.5	7.5	0.023
6	R1/8	0105 06 10	11	13	18	7.5	0.017
	R1/4	0105 06 13	14	13	18	7.5	0.024
8	R3/8	0105 06 17	17	13	18	8.5	0.030
	R1/8	0105 08 10	13	14	19.5	7	0.020
	R1/4	0105 08 13	14	14	19.5	7	0.025
8	R3/8	0105 08 17	17	14	20.5	8	0.032
	R1/8	0105 10 10	17	19	24	9	0.042
10	R1/4	0105 10 13	17	19	24	9	0.047
	R3/8	0105 10 17	17	19	24	9	0.048
12	R1/2	0105 10 21	22	19	25	10	0.066
	R1/4	0105 12 13	19	22	24	9	0.059
	R3/8	0105 12 17	19	22	24	9	0.060
12	R1/2	0105 12 21	22	22	25	10	0.076
	R1/4	0105 14 13	22	24	25	8	0.067
	R3/8	0105 14 17	22	24	25	8	0.068
14	R1/2	0105 14 21	22	24	26	9	0.080
	R3/4	0105 14 27	27	24	27	10	0.107
15	R3/8	0105 15 17	22	24	25	8	0.066
	R1/2	0105 15 21	22	24	26	9	0.077
16	R1/4	0105 16 13	24	27	27	9.5	0.090
	R3/8	0105 16 17	24	27	27	9.5	0.092
16	R1/2	0105 16 21	24	27	27	9.5	0.099
	R3/4	0105 16 27	27	27	28	10.5	0.119
18	R1/2	0105 18 21	27	30	30	10.5	0.125
	R3/4	0105 18 27	27	30	30	10.5	0.137
20	R1/2	0105 20 21	30	32	32	11	0.146
	R3/4	0105 20 27	30	32	32	11	0.157
22	R1/2	0105 22 21	32	36	33	11	0.188
	R3/4	0105 22 27	32	36	33	11	0.197
25	R1	0105 22 34	36	36	33	11	0.225
	R3/4	0105 25 27	36	41	36	11	0.263
25	R1	0105 25 34	36	41	36	11	0.277
	R3/4	0105 28 27	41	42	36	11	0.273
28	R1	0105 28 34	41	42	36	11	0.284

Metric taper threads or NPT threads are available by special order, subject to minimum quantities.

## 0105 Stud Fitting, Male NPT Thread

Brass

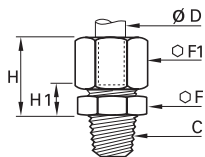

ØD	C		F	F1	H <sub>max</sub>	H1	Kg
6	NPT1/8	0105 06 11	11	13	18	7.5	0.018
	NPT1/4	0105 06 14	14	13	18	7.5	0.027
8	NPT1/8	0105 08 11	13	14	21	7	0.021
	NPT1/4	0105 08 14	14	14	18.5	7	0.026
10	NPT1/4	0105 10 14	17	19	24	9	0.047
	NPT3/8	0105 10 18	17	19	24	9	0.047
10	NPT1/2	0105 10 22	22	19	25	10	0.066

### Related Products

Parker also offers another type of brass compression fitting: **Metrolok**, with a one-piece olive/nut.

Do not hesitate to contact us.



# Brass Compression Fittings

## 0101 Stud Fitting with Captive Sealing Washer, Male BSPP and Metric Thread

Brass, technical polymer

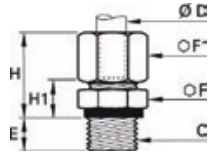

ØD	C		E	F	F1	H <sub>max</sub>	H1	Kg
4	M5x0.8	<a href="#">0101 04 19</a>	5	10	10	16.5	8	0.011
	G1/8	<a href="#">0101 04 10</a>	6.5	13	10	16.5	8	0.016
5	G1/8	<a href="#">0101 05 10</a>	6.5	13	12	17.5	8.5	0.018
6	G1/8	<a href="#">0101 06 10</a>	6.5	13	13	18	8.5	0.020
	G1/4	<a href="#">0101 06 13</a>	8	17	13	18	9.5	0.030
	G1/8	<a href="#">0101 08 10</a>	6.5	13	14	19	8.5	0.021
8	G1/4	<a href="#">0101 08 13</a>	8	17	14	19.5	9	0.031
	G3/8	<a href="#">0101 08 17</a>	11	22	14	20	10.5	0.044
	G1/4	<a href="#">0101 10 13</a>	8	17	19	24	11	0.048
10	G3/8	<a href="#">0101 10 17</a>	11	22	19	24	11.5	0.061
	G1/4	<a href="#">0101 12 13</a>	8	19	22	24	11	0.062
12	G3/8	<a href="#">0101 12 17</a>	11	22	22	24	11.5	0.070
	G1/2	<a href="#">0101 12 21</a>	12	27	22	24	12	0.089
	G3/8	<a href="#">0101 14 17</a>	11	22	24	25	10.5	0.074
14	G1/2	<a href="#">0101 14 21</a>	12	27	24	25	11	0.093
	G3/8	<a href="#">0101 15 17</a>	11	22	24	25	10.5	0.071
15	G1/2	<a href="#">0101 15 21</a>	12	27	24	25	11	0.094
	G3/8	<a href="#">0101 16 17</a>	11	22	27	27	12	0.091
16	G1/2	<a href="#">0101 16 21</a>	12	27	27	27	12.5	0.109
	G1/2	<a href="#">0101 18 21</a>	12	27	30	29.5	12.5	0.128
18	G3/4	<a href="#">0101 18 27</a>	13	32	30	29.5	13	0.152
20	G3/4	<a href="#">0101 20 27</a>	13	32	32	31	13	0.164
	G3/4	<a href="#">0101 22 27</a>	13	32	36	32	13	0.194
22	G1	<a href="#">0101 22 34</a>	15	41	36	31	13.5	0.259
	G3/4	<a href="#">0101 25 27</a>	13	36	41	35.5	13	0.260
25	G1	<a href="#">0101 25 34</a>	15	41	41	35.5	13	0.306
28	G1	<a href="#">0101 28 34</a>	15	41	42	35.5	13.5	0.299

With pre-assembled polyamide washer  
 Sealing washers 0602 can be found in chapter 9.

## 0101..39 Stud Fitting, with Bi-Material Seal, Male BSPP Thread

Brass, zinc-plated steel with NBR seal

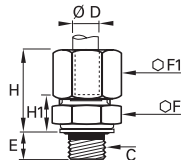

ØD	C		E	F	F1	H <sub>max</sub>	H1	Kg
4	G1/8	<a href="#">0101 04 10 39</a>	5.5	13	10	17.5	9	0.016
5	G1/8	<a href="#">0101 05 10 39</a>	5.5	13	12	18.5	9.5	0.019
6	G1/8	<a href="#">0101 06 10 39</a>	5.5	13	13	19	9.5	0.020
	G1/4	<a href="#">0101 06 13 39</a>	7	17	13	19	10.5	0.030
	G1/8	<a href="#">0101 08 10 39</a>	5.5	13	14	20	9.5	0.022
8	G1/4	<a href="#">0101 08 13 39</a>	7	17	14	20.5	10	0.031
	G3/8	<a href="#">0101 08 17 39</a>	9.5	22	14	21.5	12	0.045
	G1/4	<a href="#">0101 10 13 39</a>	7	17	19	25	12	0.048
10	G3/8	<a href="#">0101 10 17 39</a>	9.5	22	19	25.5	13	0.061
	G1/4	<a href="#">0101 12 13 39</a>	7	19	22	25	12	0.062
12	G3/8	<a href="#">0101 12 17 39</a>	9.5	22	22	25	13	0.070
	G1/2	<a href="#">0101 12 21 39</a>	10.5	27	22	25	13.5	0.090
	G3/8	<a href="#">0101 14 17 39</a>	9.5	22	24	26.5	12	0.076
14	G1/2	<a href="#">0101 14 21 39</a>	10.5	27	24	26.5	12.5	0.094
	G3/8	<a href="#">0101 15 17 39</a>	9.5	22	24	26.5	12	0.071
15	G1/2	<a href="#">0101 15 21 39</a>	10.5	27	24	26.5	12.5	0.094
	G3/8	<a href="#">0101 16 17 39</a>	9.5	22	27	28.5	13.5	0.092
16	G1/2	<a href="#">0101 16 21 39</a>	10.5	27	27	28.5	14	0.109
	G1/2	<a href="#">0101 18 21 39</a>	10.5	27	30	31	14	0.129
18	G3/4	<a href="#">0101 18 27 39</a>	11.5	32	30	31	14.5	0.154
20	G3/4	<a href="#">0101 20 27 39</a>	11.5	32	32	32.5	14.5	0.167
	G3/4	<a href="#">0101 22 27 39</a>	11.5	32	36	32.5	14.5	0.197
22	G1	<a href="#">0101 22 34 39</a>	13	41	36	33	15.5	0.259
25	G1	<a href="#">0101 25 34 39</a>	13	41	41	37.5	15.5	0.309
28	G1	<a href="#">0101 28 34 39</a>	13	41	42	37.5	15.5	0.300

Thread with bi-material seal  
 Bi-material sealing washers, part number 0139, can be found in Chapter 9

# Brass Compression Fittings

## 0101 Stud Fitting, Male Metric Thread

Brass

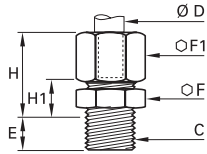

ØD	C		E	F	F1	H <sub>max</sub>	H1	Kg
4	M7x1	0101 04 55	6.5	10	10	16.5	7.5	0.012
	M8x1	0101 04 56	6.5	11	10	16.5	7.5	0.013
5	M8x1	0101 05 56	6.5	11	12	17.5	8	0.015
	M10x1	0101 05 60	6.5	14	12	17.5	8.5	0.020
6	M10x1	0101 06 60	6.5	14	13	18	8.5	0.021
	M10x1.5	0101 06 62	6.5	14	13	18	8.5	0.021
8	M12x1	0101 08 65	8	17	14	19.5	9	0.029
	M12x1.25	0101 08 66	8	17	14	19.5	9	0.029
	M13x1.25	0101 08 68	8	17	14	19.5	9	0.030
10	M14x1.25	0101 10 70	8	17	19	24	11	0.048
	M14x1.5	0101 10 71	8	17	19	24	11	0.047
	M16x1.25	0101 10 74	9	19	19	24	11	0.051
	M16x1.5	0101 10 75	9	19	19	24	11	0.051
12	M18x1.5	0101 10 78	9	22	19	24	11.5	0.060
	M16x1.25	0101 12 74	9	19	22	24	11	0.061
	M16x1.5	0101 12 75	9	19	22	24	11	0.061
14	M18x1.5	0101 12 78	9	22	22	24	11.5	0.071
	M18x1.5	0101 14 78	9	22	24	25	10.5	0.073
	M20x1.5	0101 14 80	10	24	24	25	11	0.084
15	M18x1.5	0101 15 78	9	22	24	25	10.5	0.071
	M20x1.5	0101 16 80	10	24	27	27	12.5	0.101
16	M22x1.5	0101 16 82	10	27	27	27	12.5	0.110
	M22x1.5	0101 18 82	10	27	30	29.5	12.5	0.129
18	M24x1.5	0101 18 83	11	30	30	29.5	13	0.142

## 0114 Stud Fitting, Female BSPP Thread

Brass

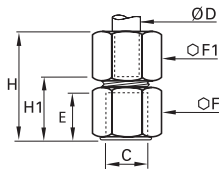

ØD	C		E	F	F1	H <sub>max</sub>	H1	Kg
4	G1/8	0114 04 10	9.5	14	10	26	16.5	0.020
	G1/4	0114 04 13	13.5	17	10	30	20.5	0.030
5	G1/8	0114 05 10	9.5	14	12	28	17	0.023
	G1/4	0114 05 13	13.5	17	12	31	21	0.033
6	G1/8	0114 06 10	9.5	14	13	28	17	0.025
	G1/4	0114 06 13	13.5	17	13	32	21	0.034
8	G3/8	0114 06 17	14	22	13	32	21.5	0.051
	G1/8	0114 08 10	9.5	14	14	29	16.5	0.026
	G1/4	0114 08 13	13.5	17	14	33	20.5	0.035
10	G3/8	0114 08 17	14	22	14	34	21	0.052
	G1/4	0114 10 13	13.5	17	19	37	21.5	0.052
	G3/8	0114 10 17	14	22	19	37	22	0.068
12	G1/2	0114 10 21	18.5	27	19	42	26.5	0.100
	G1/4	0114 12 13	13.5	19	22	36	20.5	0.068
	G3/8	0114 12 17	14	22	22	37	22	0.078
14	G1/2	0114 12 21	18.5	27	22	42	26.5	0.109
	G1/4	0114 14 13	13.5	22	24	36	18.5	0.085
	G3/8	0114 14 17	14	22	24	38	21	0.048
15	G1/2	0114 14 21	18.5	27	24	43	25.5	0.112
	G3/8	0114 15 17	14	22	24	38	21	0.078
	G1/2	0114 15 21	18.5	27	24	43	25.5	0.109
16	G1/4	0114 16 13	13.5	24	27	36	18	0.107
	G3/8	0114 16 17	14	24	27	38	20.5	0.106
	G1/2	0114 16 21	18.5	27	27	44	26	0.128
18	G3/8	0114 18 17	14	27	30	39	19.5	0.140
	G1/2	0114 18 21	18.5	27	30	45	26	0.144
	G3/4	0114 18 27	19.5	32	30	46	27	0.164
20	G3/8	0114 20 17	14	30	32	38	18	0.161
	G1/2	0114 20 21	18.5	30	32	44.5	24	0.171
	G3/4	0114 20 27	19.5	32	32	47	26.5	0.171
22	G1/2	0114 22 27	19.5	32	36	48	26.5	0.203
	G3/4	0114 22 27	19.5	32	36	48	26.5	0.203
25	G3/4	0114 25 27	19.5	36	41	50.5	26	0.297

Brass Compression Fittings

Compression Fittings

# Brass Compression Fittings

## 0109 Stud Elbow, Male BSPT Thread

Brass

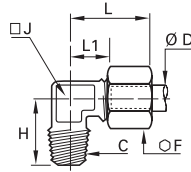

ØD	C		F	H	J	L <sub>max</sub>	L1	Kg
4	R1/8	<a href="#">0109 04 10</a>	10	17	8	19	9.5	0.016
	R1/4	<a href="#">0109 04 13</a>	10	20	10	19	11	0.024
5	R1/8	<a href="#">0109 05 10</a>	12	17.5	8	21	11	0.019
	R1/4	<a href="#">0109 05 13</a>	12	21.5	10	22	12	0.029
6	R1/8	<a href="#">0109 06 10</a>	13	18	8	22	11	0.021
	R1/4	<a href="#">0109 06 13</a>	13	21.5	10	22	12	0.030
8	R1/8	<a href="#">0109 08 10</a>	14	18.5	10	28	15	0.028
	R1/4	<a href="#">0109 08 13</a>	14	22	10	28	15	0.034
	R3/8	<a href="#">0109 08 17</a>	14	24	12	28	15	0.043
10	R1/4	<a href="#">0109 10 13</a>	19	25	12	30	14.5	0.053
	R3/8	<a href="#">0109 10 17</a>	19	25.5	12	30	14.5	0.059
	R1/2	<a href="#">0109 10 21</a>	19	32	19	36	21	0.108
12	R1/4	<a href="#">0109 12 13</a>	22	26	15	30	15	0.074
	R3/8	<a href="#">0109 12 17</a>	22	27	15	30	15	0.077
14	R1/2	<a href="#">0109 12 21</a>	22	32	19	36	21	0.114
	R3/8	<a href="#">0109 14 17</a>	24	30	19	35	18	0.105
15	R1/2	<a href="#">0109 14 21</a>	24	32	19	35	18	0.111
	R3/8	<a href="#">0109 15 17</a>	24	30	19	35	18	0.100
	R1/2	<a href="#">0109 15 21</a>	24	32	19	35	18	0.108
16	R3/8	<a href="#">0109 16 17</a>	27	30	19	39	21	0.121
	R1/2	<a href="#">0109 16 21</a>	27	33.5	19	39	21	0.129
	R3/4	<a href="#">0109 16 27</a>	27	36.5	23	41	23	0.185
18	R1/2	<a href="#">0109 18 21</a>	30	35.5	23	41	21.5	0.179
	R3/4	<a href="#">0109 18 27</a>	30	36.5	23	41	21.5	0.198
20	R1/2	<a href="#">0109 20 21</a>	32	36.5	23	42	21.5	0.183
	R3/4	<a href="#">0109 20 27</a>	32	38	23	42	21.5	0.203
22	R3/4	<a href="#">0109 22 27</a>	36	40	27	50	30	0.287
	R1	<a href="#">0109 22 34</a>	36	44	27	50	30	0.336
25	R3/4	<a href="#">0109 25 27</a>	41	43	27	54	30	0.328
	R1	<a href="#">0109 25 34</a>	41	44	27	54	30	0.368
28	R3/4	<a href="#">0109 28 27</a>	42	46	32	54	30	0.404
	R1	<a href="#">0109 28 34</a>	42	48	32	54	30	0.382

Metric taper threads or NPT threads are available by special order, subject to minimum quantities.

## 0109 Stud Elbow, Male NPT Thread

Brass

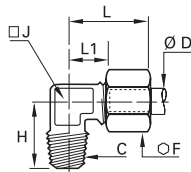

ØD	C		F	H	J	L <sub>max</sub>	L1	Kg
6	NPT1/8	<a href="#">0109 06 11</a>	13	18	8	22	11	0.021
	NPT1/4	<a href="#">0109 06 14</a>	13	21.5	10	22	12	0.030
8	NPT1/8	<a href="#">0109 08 11</a>	14	18.5	10	28	15	0.028
	NPT1/4	<a href="#">0109 08 14</a>	14	22	10	28	15	0.033
10	NPT1/4	<a href="#">0109 10 14</a>	19	25	12	30	14.5	0.053

## 0199 Stud Orientable Elbow, Male BSPP Thread

Brass, NBR

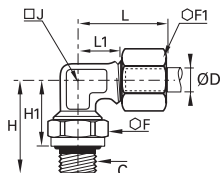

ØD	C		F	F1	H	H1	H1 <sub>max</sub>	J	L <sub>max</sub>	L1	Kg
4	G1/8	<a href="#">0199 04 10</a>	14	10	23	16	17	8	19	9.5	0.022
	G1/4	<a href="#">0199 04 13</a>	19	10	30.5	22	23.5	10	19	11	0.043
6	G1/8	<a href="#">0199 06 10</a>	14	13	23	16	17	8	22	11	0.027
	G1/4	<a href="#">0199 06 13</a>	19	13	30.5	22	23.5	10	22	12	0.046
8	G1/8	<a href="#">0199 08 10</a>	14	14	24	17	18	10	28	15	0.034
	G1/4	<a href="#">0199 08 13</a>	19	14	30.5	22	23.5	10	28	15	0.049
10	G3/8	<a href="#">0199 08 17</a>	22	14	33.5	24	25.5	12	28	15	0.065
	G1/4	<a href="#">0199 10 13</a>	19	19	31	22.5	24	12	30	14.5	0.067
	G3/8	<a href="#">0199 10 17</a>	22	19	33.5	24	25.5	12	30	14.5	0.078
14	G1/2	<a href="#">0199 10 21</a>	27	19	40	29.5	31	19	37	22	0.137
	G3/8	<a href="#">0199 14 17</a>	22	24	35.5	26	27.5	19	35	18	0.118
18	G1/2	<a href="#">0199 14 21</a>	27	24	40	29.5	31	19	35	18	0.140
	G1/2	<a href="#">0199 18 21</a>	27	30	40	29	30.5	23	41	21.5	0.187
22	G3/4	<a href="#">0199 18 27</a>	32	30	43.5	32	33.5	23	41	21.5	0.222
	G3/4	<a href="#">0199 22 27</a>	32	36	45.5	34	36	32	51	31	0.385
28	G1	<a href="#">0199 22 34</a>	41	36	54	40.5	43	32	51	31	0.409
	G1	<a href="#">0199 28 34</a>	41	42	54	40.5	43	32	54	30	0.411

The body will orientate for positioning purposes.

# Brass Compression Fittings

## 0108 Stud Branch Tee, Male BSPT Thread

Brass

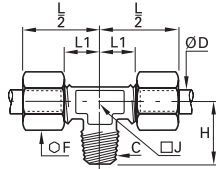

ØD	C		F	H	J	L1	L2	Kg
4	R1/8	<a href="#">0108 04 10</a>	10	17	8	9.5	19	0.025
5	R1/8	<a href="#">0108 05 10</a>	12	17.5	8	11	21	0.031
6	R1/8	<a href="#">0108 06 10</a>	13	18	8	11	22	0.033
	R1/4	<a href="#">0108 06 13</a>	13	21.5	10	16	27	0.047
8	R1/8	<a href="#">0108 08 10</a>	14	18.5	10	15	28	0.043
	R1/4	<a href="#">0108 08 13</a>	14	22	10	15	28	0.050
10	R3/8	<a href="#">0108 08 17</a>	14	24	12	15	28	0.061
	R1/4	<a href="#">0108 10 13</a>	19	25	12	14.5	30	0.085
12	R3/8	<a href="#">0108 10 17</a>	19	25.5	12	14.5	30	0.092
	R1/4	<a href="#">0108 12 13</a>	22	26	15	15	30	0.114
14	R3/8	<a href="#">0108 12 17</a>	22	27	15	15	30	0.117
	R1/2	<a href="#">0108 14 21</a>	24	32	19	18	35	0.166
15	R3/8	<a href="#">0108 15 17</a>	24	30	19	18	35	0.147
	R1/2	<a href="#">0108 15 21</a>	24	32	19	18	35	0.155
16	R3/8	<a href="#">0108 16 17</a>	27	30	19	21	39	0.190
	R1/2	<a href="#">0108 16 21</a>	27	33.5	19	21	39	0.203
18	R1/2	<a href="#">0108 18 21</a>	30	35.5	23	21.5	41	0.270
	R3/4	<a href="#">0108 18 27</a>	30	36.5	23	21.5	41	0.292
20	R3/4	<a href="#">0108 20 27</a>	32	38	23	21.5	42	0.299
22	R3/4	<a href="#">0108 22 27</a>	36	40	27	29	50	0.431
	R1	<a href="#">0108 22 34</a>	36	44	27	29	50	0.466

Metric taper threads or NPT threads are available by special order, subject to minimum quantities.

## 0103 Stud Run Tee, Male BSPT Thread

Brass

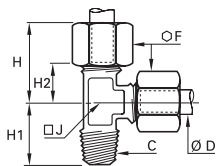

ØD	C		F	H max	H1	H2	J	Kg
4	R1/8	<a href="#">0103 04 10</a>	10	19	17	9.5	8	0.025
5	R1/8	<a href="#">0103 05 10</a>	12	21	17.5	11	8	0.030
6	R1/8	<a href="#">0103 06 10</a>	13	22	18	11	8	0.033
	R1/4	<a href="#">0103 06 13</a>	13	27	21.5	16	10	0.046
8	R1/8	<a href="#">0103 08 10</a>	14	28	18.5	15	10	0.044
	R1/4	<a href="#">0103 08 13</a>	14	28	22	15	10	0.049
10	R3/8	<a href="#">0103 08 17</a>	14	28	24	15	12	0.061
	R1/4	<a href="#">0103 10 13</a>	19	30	25	14.5	12	0.084
12	R3/8	<a href="#">0103 10 17</a>	19	30	25.5	14.5	12	0.091
	R1/4	<a href="#">0103 12 13</a>	22	30	26	15	15	0.114
14	R3/8	<a href="#">0103 12 17</a>	22	30	27	15	15	0.121
	R3/8	<a href="#">0103 14 17</a>	24	35	30	18	19	0.161
15	R1/2	<a href="#">0103 14 21</a>	24	35	32	18	19	0.171
	R3/8	<a href="#">0103 15 17</a>	24	35	30	18	19	0.148
16	R1/2	<a href="#">0103 15 21</a>	24	35	32	18	19	0.158
	R3/8	<a href="#">0103 16 17</a>	27	39	30	21	19	0.188
18	R1/2	<a href="#">0103 16 21</a>	27	39	33.5	21	19	0.202
	R1/2	<a href="#">0103 18 21</a>	30	41	35.5	21.5	23	0.269
20	R3/4	<a href="#">0103 18 27</a>	30	41	36.5	21.5	23	0.291
	R3/4	<a href="#">0103 20 27</a>	32	42	38	21.5	23	0.298
22	R3/4	<a href="#">0103 22 27</a>	36	50	40	29	27	0.435

Metric taper threads or NPT threads are available by special order, subject to minimum quantities.

### Related Products

Parker also offers another type of brass compression fitting: **Metrolok**, with a one-piece olive/nut. Do not hesitate to contact us.



# Brass Compression Fittings

## 0118 Single Banjo with Captive Sealing Washer, Male BSPP Thread

Brass, technical polymer

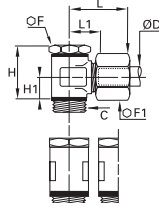

ØD	C		F	F1	H	H1	L <sub>max</sub>	L1	N	Kg
4	G1/8	<a href="#">0118 04 10</a>	14	10	24	9.5	24	14.5	17.5	0.038
5	G1/8	<a href="#">0118 05 10</a>	14	12	24	9.5	25	14.5	17.5	0.041
	G1/4	<a href="#">0118 05 13</a>	17	12	25	10	26	16	21	0.058
6	G1/8	<a href="#">0118 06 10</a>	14	13	24	9.5	25	14.5	17.5	0.041
	G1/4	<a href="#">0118 06 13</a>	17	13	25	10	26	16	21	0.056
8	G1/8	<a href="#">0118 08 10</a>	14	14	24	9.5	28	15.5	17.5	0.055
	G1/4	<a href="#">0118 08 13</a>	17	14	25	10	28	15.5	21	0.058
10	G3/8	<a href="#">0118 08 17</a>	22	14	32	13	30	18	26.5	0.110
	G1/4	<a href="#">0118 10 13</a>	17	19	31	13	34	19	23	0.117
12	G3/8	<a href="#">0118 10 17</a>	22	19	32	13	34	19	26.5	0.125
	G1/4	<a href="#">0118 12 13</a>	17	22	34	14.5	34	19	23	0.126
14	G3/8	<a href="#">0118 12 17</a>	22	22	35	14.5	34	19	26.5	0.138
	G1/4	<a href="#">0118 14 13</a>	17	24	37	16	37	20.5	28	0.154
15	G3/8	<a href="#">0118 14 17</a>	22	24	38	16	37	20.5	28	0.202
	G1/2	<a href="#">0118 14 21</a>	27	24	40	16	38	20.5	32.5	0.202
16	G3/8	<a href="#">0118 15 17</a>	22	24	38	16	37	20.5	28	0.189
	G1/2	<a href="#">0118 15 21</a>	27	24	40	16	38	20.5	32.5	0.196
18	G1/2	<a href="#">0118 16 21</a>	27	27	42	16	38	21	32.5	0.219
20	G3/4	<a href="#">0118 18 21</a>	27	30	46	19.5	43	24.5	36	0.362
22	G3/4	<a href="#">0118 20 27</a>	32	32	49	20	44	24.5	39	0.406
	G3/4	<a href="#">0118 22 27</a>	32	36	53	22	45	24.5	39	0.454

Thread with pre-assembled washer  
Sealing washers 0602 can be found in chapter 9.

## 0118..39 Single Banjo with Bi-Material Seal, Male BSPP Thread

Brass, zinc-plated steel with NBR seal

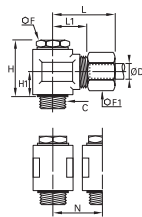

ØD	C		F	F1	H	H1	L <sub>max</sub>	L1	N	Kg
4	G1/8	<a href="#">0118 04 10 39</a>	14	10	23	9.5	24	14.5	17.5	0.039
5	G1/8	<a href="#">0118 05 10 39</a>	14	12	23	9.5	25	14.5	17.5	0.041
	G1/4	<a href="#">0118 05 13 39</a>	17	12	24	10	26	16	21	0.064
6	G1/8	<a href="#">0118 06 10 39</a>	14	13	23	9.5	25	14.5	17.5	0.042
	G1/4	<a href="#">0118 06 13 39</a>	17	13	24	10	26	16	21	0.057
8	G1/8	<a href="#">0118 08 10 39</a>	14	14	23	9.5	28	15.5	17.5	0.056
	G1/4	<a href="#">0118 08 13 39</a>	17	14	24	10	28	15.5	21	0.059
10	G3/8	<a href="#">0118 08 17 39</a>	22	14	31.5	13.5	30	18	26.5	0.113
	G1/4	<a href="#">0118 10 13 39</a>	17	19	30	13	34	19	23	0.119
12	G3/8	<a href="#">0118 10 17 39</a>	22	19	31.5	13.5	34	19	26.5	0.127
	G1/4	<a href="#">0118 12 13 39</a>	17	22	33	14.5	34	19	23	0.126
14	G3/8	<a href="#">0118 12 17 39</a>	22	22	34.5	15	34	19	26.5	0.136
	G1/4	<a href="#">0118 14 13 39</a>	17	24	36	16	37	20.5	28	0.190
15	G3/8	<a href="#">0118 14 17 39</a>	22	24	37.5	16.5	37	20.5	28	0.198
	G1/2	<a href="#">0118 14 21 39</a>	27	24	39	16.5	38	20.5	32.5	0.206
16	G1/2	<a href="#">0118 15 21 39</a>	27	24	40	16.5	38	20.5	32.5	0.202
18	G1/2	<a href="#">0118 16 21 39</a>	27	27	40	16.5	38	21	32.5	0.222
20	G1/2	<a href="#">0118 18 21 39</a>	27	30	47	20	43	24.5	36	0.365
	G3/4	<a href="#">0118 20 27 39</a>	32	32	50	20.5	44	24.5	39	0.394
22	G3/4	<a href="#">0118 22 27 39</a>	32	36	54	22.5	45	24.5	39	0.462

With bi-material sealing washer  
The bi-material sealing washers, part number 0139, can be found in chapter 9.

# Brass Compression Fittings

## 0119 Double Banjo with Captive Sealing Washer, Male BSPP Thread

Brass, technical polymer

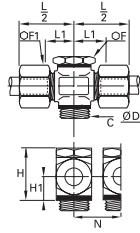

ØD	C		F	F1	H	H1	L1	L/2	N	Kg
4	G1/8	<a href="#">0119 04 10</a>	14	10	24	9.5	14.5	24	17.5	0.051
6	G1/8	<a href="#">0119 06 10</a>	14	13	24	9.5	14.5	25	17.5	0.056
	G1/4	<a href="#">0119 06 13</a>	17	13	25	10	16	26.5	21	0.073
8	G1/8	<a href="#">0119 08 10</a>	14	14	24	9.5	15.5	28	17.5	0.070
	G1/4	<a href="#">0119 08 13</a>	17	14	25	10	15.5	28	21	0.075
10	G3/8	<a href="#">0119 08 17</a>	22	14	32	13	18	30.5	26.5	0.140
	G1/4	<a href="#">0119 10 13</a>	17	19	31	13	19	34	23	0.156
12	G3/8	<a href="#">0119 10 17</a>	22	19	32	13	19	34	26.5	0.173
	G1/4	<a href="#">0119 12 13</a>	17	22	34	14.5	19	34	23	0.173
14	G3/8	<a href="#">0119 12 17</a>	22	22	35	14.5	19	34	26.5	0.182
	G1/4	<a href="#">0119 14 13</a>	17	24	37	16	20.5	37.5	28	0.246
	G3/8	<a href="#">0119 14 17</a>	22	24	38	16	20.5	37.5	28	0.245
14	G1/2	<a href="#">0119 14 21</a>	27	24	40	16	20.5	38	32.5	0.219

Thread with pre-assembled washer  
 Sealing washers 0602 can be found in Chapter 9.

## 0119..39 Double Banjo with Bi-Material Seal, Male BSPP Thread

Brass, zinc-plated steel with NBR seal

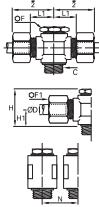

ØD	C		F	F1	H	H1	L1	L/2	N	Kg
4	G1/8	<a href="#">0119 04 10 39</a>	14	10	23	9.5	14.5	24	17.5	0.050
5	G1/8	<a href="#">0119 05 10 39</a>	14	12	23	9.5	14.5	25	17.5	0.049
	G1/4	<a href="#">0119 05 13 39</a>	17	12	24	10	126	26	21	0.072
6	G1/8	<a href="#">0119 06 10 39</a>	14	13	23	9.5	14.5	25	17.5	0.057
	G1/4	<a href="#">0119 06 13 39</a>	17	13	24	10	16	26	21	0.071
8	G1/8	<a href="#">0119 08 10 39</a>	14	14	23	9.5	15.5	28	17.5	0.071
	G1/4	<a href="#">0119 08 13 39</a>	17	14	24	10	15.5	28	21	0.075
10	G3/8	<a href="#">0119 08 17 39</a>	22	14	31.5	13.5	18	30	26.5	0.137
	G1/4	<a href="#">0119 10 13 39</a>	17	19	30	13	19	34	23	0.156
12	G3/8	<a href="#">0119 10 17 39</a>	22	19	31.5	13.5	19	34	26.5	0.167
	G1/4	<a href="#">0119 12 13 39</a>	17	22	33	14.5	19	34	23	0.180
14	G1/4	<a href="#">0119 14 13 39</a>	17	24	36	16	20.5	37	28	0.248
	G3/8	<a href="#">0119 14 17 39</a>	22	24	39	16.5	20.5	37	28	0.247
	G1/2	<a href="#">0119 14 21 39</a>	27	24	39	16.5	20.5	38	32.5	0.261
15	G3/8	<a href="#">0119 15 17 39</a>	22	24	37.5	16.5	20.5	37	28	0.246
	G1/2	<a href="#">0119 15 21 39</a>	27	24	40	16.5	20.5	38	32.5	0.251
18	G1/2	<a href="#">0119 18 21 39</a>	27	30	47	20	24.5	43	36	0.471
20	G3/4	<a href="#">0119 20 27 39</a>	32	32	50	20.5	24.5	44	39	0.638
22	G3/4	<a href="#">0119 22 27 39</a>	32	36	54	22.5	24.5	45	39	0.610

Thread with pre-assembled washer  
 Bi-material sealing washers, part number 0139, can be found in Chapter 9.

## 0106 Equal Tube-to-Tube Connector

Brass

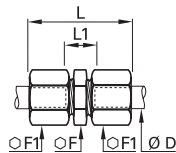

ØD		F	F1	L <sub>max</sub>	L1	Kg
4	<a href="#">0106 04 00</a>	10	10	28	10	0.017
5	<a href="#">0106 05 00</a>	11	12	31	11	0.024
6	<a href="#">0106 06 00</a>	11	13	32	11	0.026
8	<a href="#">0106 08 00</a>	13	14	36	10	0.031
10	<a href="#">0106 10 00</a>	17	19	42	13	0.070
12	<a href="#">0106 12 00</a>	19	22	42	13	0.091
14	<a href="#">0106 14 00</a>	22	24	45	11	0.103
15	<a href="#">0106 15 00</a>	22	24	45	11	0.098
16	<a href="#">0106 16 00</a>	24	27	48	13	0.142
18	<a href="#">0106 18 00</a>	27	30	53	14	0.188
20	<a href="#">0106 20 00</a>	30	32	56	14	0.215
22	<a href="#">0106 22 00</a>	32	36	60	14	0.282
25	<a href="#">0106 25 00</a>	36	41	64	14	0.401
28	<a href="#">0106 28 00</a>	41	42	64	14	0.397

# Brass Compression Fittings

## 0113 Equal Tube-to-Tube Connector with Mounting Boss

Brass

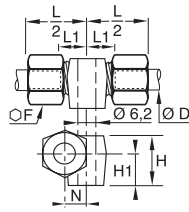

ØD		F	H	H1	L1	L/2	N	Kg
4	<a href="#">0113 04 00</a>	10	10.5	7	9.5	19	6	0.021
6	<a href="#">0113 06 00</a>	13	13	9	10	20.5	7	0.033
8	<a href="#">0113 08 00</a>	14	14.5	9.5	11	23.5	8	0.040
10	<a href="#">0113 10 00</a>	19	19.5	12.5	11	26	9	0.081
12	<a href="#">0113 12 00</a>	22	22	14	12	26.5	11	0.108
14	<a href="#">0113 14 00</a>	24	25	16	11	28	12	0.124

## 0116 Equal Bulkhead Connector

Brass

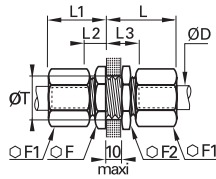

ØD		F	F1	F2	L max	L1 max	L2	L3	ØT min	Kg
4	<a href="#">0116 04 00</a>	10	10	13	27	17	7	17	8.3	0.024
5	<a href="#">0116 05 00</a>	13	12	14	28	18	7.5	17.5	10.3	0.035
6	<a href="#">0116 06 00</a>	13	13	14	28	19	7.5	17.5	10.3	0.037
8	<a href="#">0116 08 00</a>	14	14	17	29	20	7	17	12.3	0.045
10	<a href="#">0116 10 00</a>	19	19	22	33	25	9	19	16.5	0.100
12	<a href="#">0116 12 00</a>	22	22	22	33	25	9	19	18.5	0.121
14	<a href="#">0116 14 00</a>	24	24	27	35	25	8	18	20.5	0.144
15	<a href="#">0116 15 00</a>	24	24	24	35	25	8	18	20.5	0.134
16	<a href="#">0116 16 00</a>	27	27	27	36	28	9.5	19.5	22.5	0.188
18	<a href="#">0116 18 00</a>	27	30	30	40	30	10.5	20.5	24.5	0.238
20	<a href="#">0116 20 00</a>	32	30	32	41	31	11	21	27.5	0.275
22	<a href="#">0116 22 00</a>	36	36	36	42	32	11	21	30.5	0.376
25	<a href="#">0116 25 00</a>	36	41	38	46	36	11	21	33.5	0.479

## 0102 Equal Elbow

Brass

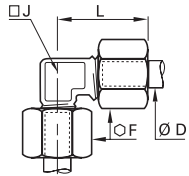

ØD		F	J	L max	Kg
4	<a href="#">0102 04 00</a>	10	5	19	0.016
5	<a href="#">0102 05 00</a>	12	8	21	0.025
6	<a href="#">0102 06 00</a>	13	8	22	0.027
8	<a href="#">0102 08 00</a>	14	10	28	0.038
10	<a href="#">0102 10 00</a>	19	12	30	0.072
12	<a href="#">0102 12 00</a>	22	15	30	0.098
14	<a href="#">0102 14 00</a>	24	19	35	0.133
15	<a href="#">0102 15 00</a>	24	19	35	0.123
16	<a href="#">0102 16 00</a>	27	19	39	0.165
18	<a href="#">0102 18 00</a>	30	23	41	0.230
20	<a href="#">0102 20 00</a>	32	23	42	0.236
22	<a href="#">0102 22 00</a>	36	27	50	0.373
25	<a href="#">0102 25 00</a>	41	27	54	0.452
28	<a href="#">0102 28 00</a>	42	32	54.5	0.474

### Related Products

Parker also offers another type of brass compression fitting: **Metroluk**, with a one-piece olive/nut.

Do not hesitate to contact us.



# Brass Compression Fittings

## 0104 Equal Tee

Brass

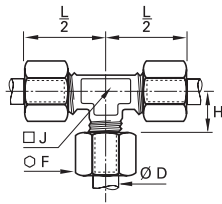

ØD		F	H	J	L/2	Kg
4	<a href="#">0104 04 00</a>	10	9.5	8	19	0.028
5	<a href="#">0104 05 00</a>	12	11	8	21	0.036
6	<a href="#">0104 06 00</a>	13	11	8	22	0.040
8	<a href="#">0104 08 00</a>	14	15	10	28	0.055
10	<a href="#">0104 10 00</a>	19	14.5	12	30	0.105
12	<a href="#">0104 12 00</a>	22	15	15	30	0.141
14	<a href="#">0104 14 00</a>	24	18	19	35	0.186
15	<a href="#">0104 15 00</a>	24	18	19	35	0.174
16	<a href="#">0104 16 00</a>	27	21	19	39	0.234
18	<a href="#">0104 18 00</a>	30	21.5	23	41	0.319
20	<a href="#">0104 20 00</a>	32	21.5	23	42	0.330
22	<a href="#">0104 22 00</a>	36	29	27	50	0.516
25	<a href="#">0104 25 00</a>	41	29	27	54	0.637
28	<a href="#">0104 28 00</a>	42	30	32	55	0.661

## 0142 Equal Y Piece with Mounting Boss

Brass

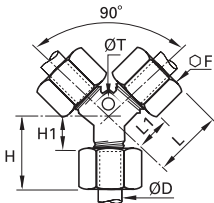

ØD		F	H <sub>max</sub>	H1	L <sub>max</sub>	L1	ØT	Kg
4	<a href="#">0142 04 00</a>	10	16.5	7	26.5	17	4.2	0.032
6	<a href="#">0142 06 00</a>	13	19.5	8.5	28	17	4.2	0.049
8	<a href="#">0142 08 00</a>	14	21	8	30	17	6.2	0.061
10	<a href="#">0142 10 00</a>	19	24.5	9	37.5	22	6.2	0.128
12	<a href="#">0142 12 00</a>	22	26	11	38	23	6.2	0.110
14	<a href="#">0142 14 00</a>	24	28	11	41.5	24.5	6.2	0.201
15	<a href="#">0142 15 00</a>	24	28	11	41.5	24.5	6.2	0.204
16	<a href="#">0142 16 00</a>	27	30	12	43	25	6.2	0.252
18	<a href="#">0142 18 00</a>	30	31.5	12	50.5	31	10.2	0.353

## 0107 Equal Cross

Brass

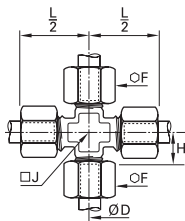

ØD		F	H	J	L/2	Kg
4	<a href="#">0107 04 00</a>	10	9.5	8	19	0.035
5	<a href="#">0107 05 00</a>	12	11	8	21	0.047
6	<a href="#">0107 06 00</a>	13	11	8	22	0.052
8	<a href="#">0107 08 00</a>	14	15	11	28	0.074
10	<a href="#">0107 10 00</a>	19	14.5	14	30	0.142
12	<a href="#">0107 12 00</a>	22	15	15	35	0.234
14	<a href="#">0107 14 00</a>	24	18	20	35	0.246
15	<a href="#">0107 15 00</a>	24	18	20	35	0.224
16	<a href="#">0107 16 00</a>	27	21	20	39	0.309
18	<a href="#">0107 18 00</a>	30	21.5	25	41	0.423
20	<a href="#">0107 20 00</a>	32	21.5	25	42	0.429
22	<a href="#">0107 22 00</a>	36	29	27	50	0.670
25	<a href="#">0107 25 00</a>	41	29	27	50	0.833

Brass Compression Fittings

Compression Fittings

# Complementary Brass Fittings Reducers, Olives and Nuts

This innovative reducer system, using a full range of nuts and olives, enables **different diameters** of steel, copper, brass or polymer tubes to be fitted onto **a single Parker Legris compression fitting**.

## Product Advantages

**Efficient Solution** Reduces envelope dimensions  
 Quick and easy to assemble, whatever the diameters and tube material  
 Improved stock management  
 Silicone-free

**Multiple Combinations** A single connector for up to 4 different tube materials and sizes  
 Example:
 

- polymer tube 4 mm O.D.
- copper tube 8 mm O.D.
- brass tube 12 mm O.D.
- braided PVC hose 12 mm I.D.

 A full range of olives and nuts to optimise all assembly operations





Pneumatics  
 Cooling  
 Automotive Process  
 Lubrication  
 Fluid Transmission  
 Packaging  
 Industrial Machinery

**Applications**

### Regulations

- DI:** 97/23/EC (PED)
- RG:** 1907/2006 (REACH)
- DI:** 2002/95/EC (RoHS)
- DI:** 94/9/EC (ATEX)

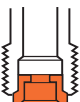
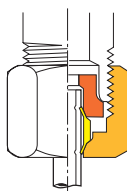
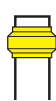
## Reducer Assembly Procedure







Operation	Assembly Sequence	Assembled Fitting
<b>1</b> <b>Assemble the reducer</b> Place the reducer in the fitting body.	<b>1</b> 	
<b>2</b> <b>Assemble the nut and olive</b> Place the nut and then the olive onto the tube.	<b>2</b> 	
<b>3</b> <b>Assemble the nut</b> Push the tubing into the fitting until it butts against the tube reducer. Tighten the nut to the recommended torque (see opposite page).	<b>3</b> 	

# Complementary Brass Fittings

## Assembly Configuration

The table and information given below illustrate the large number of options available with Parker Legris brass compression fittings. To these must be added the advantages specific to the original Parker Legris reducer shown on the previous page.

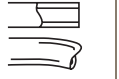

0110 Brass			0110..60 Brass		0110..40 Steel		0110..70* Polymer			
0124 Brass	0111 BNA** Brass		0124 Brass	0111 BNA** Brass		0124...40 Steel				
No olive required to assemble the plug			No olive required to assemble the tube		No olive required to assemble the tube		No olive required to assemble the tube			
Brass plug: <b>0126</b> 			Cold-rolled copper tube for vibration and side loading, etc. 		Coiled annealed copper tube for vibration and side loading, etc. 		Steel or copper tube: low/medium hydraulic pressure, lubricate before assembly 		Polymer tube 	
Copper, cold-rolled brass, polymer tube and barb connectors <b>0122</b> and <b>0165</b> 			Coiled annealed copper tube 							

### \*Assembly specifications for nut-olive 0110 ..70

This part functions as both olive and nut for flexible polymer tube assemblies:

1. Hand tighten the polymer nut-olive a few turns onto the body of the fitting; the knurling makes this easier.
2. Then introduce the polymer tube and push home into the body of the fitting.
3. Continue manually tightening the polymer nut-olive.
4. Finish tightening using a spanner until the nut body disengages and turns freely, which acts as a torque limiter.

**N.B.:** To avoid damaging the threads, do not insert the tube before hand tightening the nut-olive into the body of the fitting.

\*\*Bureau de Normalisation de l'Automobile (French Automotive Bureau of Standards)

### Recommended Tightening Torque

#### Tightening torque in daN.m =

maximum tightening torque of a **0110** nut and **0124** olive with copper, brass or steel tube.

Nut **0110** and **0110..40**

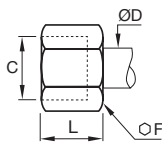

Nut **0110..60**

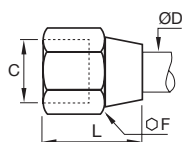

Ø D (mm)	OF 0110	OF 0110..60	max. daN.m copper or brass	OF 0110..40	max. daN.m steel
4	10	11	0.7	10	1.5
5	12	13	0.7	12	1.5
6	13	13	1.5	13	2.5
8	14	16	1.5	14	2.5
10	19	20	1.8	19	3
12	22	22	3	22	4.5
14	24	24	3.5	24	5.5
15	24	24	4	24	6
16	27	27	5	27	7
18	30	30	6	30	9
20	32	32	6	32	10
22	36	36	7	36	12
25	41	41	8	41	13
28	42		9		

# Complementary Brass Compression Fittings

## 0166 3-Piece Reducer

Brass

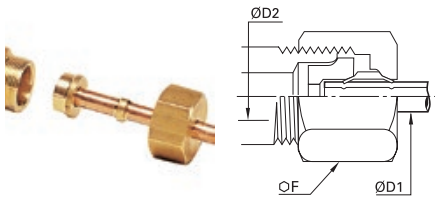

ØD1	ØD2		F	Kg
4	5	0166 04 05	13	0.011
	6	0166 04 06	13	0.011
	8	0166 04 08	14	0.012
	10	0166 04 10	19	0.030
	12	0166 04 12	22	0.044
	14	0166 04 14	24	0.054
5	15	0166 04 15	24	0.056
	6	0166 05 06	13	0.011
	8	0166 05 08	14	0.012
	10	0166 05 10	19	0.030
	12	0166 05 12	22	0.044
	14	0166 05 14	24	0.053
6	16	0166 05 16	27	0.078
	8	0166 06 08	14	0.011
	10	0166 06 10	19	0.030
	12	0166 06 12	22	0.043
	14	0166 06 14	24	0.052
	15	0166 06 15	24	0.054
8	16	0166 06 16	27	0.077
	10	0166 08 10	19	0.027
	12	0166 08 12	22	0.040
	14	0166 08 14	24	0.050
	15	0166 08 15	24	0.052
	16	0166 08 16	27	0.077
10	18	0166 08 18	30	0.099
	12	0166 10 12	22	0.037
	14	0166 10 14	24	0.045
	15	0166 10 15	24	0.047
	16	0166 10 16	27	0.068
	18	0166 10 18	30	0.095
12	20	0166 10 20	32	0.107
	22	0166 10 22	36	0.146
	25	0166 10 25	41	0.209
	14	0166 12 14	24	0.042
	15	0166 12 15	24	0.044
	16	0166 12 16	27	0.066
14	18	0166 12 18	30	0.091
	20	0166 12 20	32	0.102
	22	0166 12 22	36	0.141
	25	0166 12 25	41	0.200
	16	0166 14 16	27	0.060
	18	0166 14 18	30	0.085
15	20	0166 14 20	32	0.095
	22	0166 14 22	36	0.134
	25	0166 14 25	41	0.189
	18	0166 15 18	30	0.081
16	22	0166 15 22	36	0.130
	18	0166 16 18	30	0.078
	20	0166 16 20	32	0.087
	22	0166 16 22	36	0.125
18	25	0166 16 25	41	0.185
	20	0166 18 20	32	0.082
	22	0166 18 22	36	0.118
	25	0166 18 25	41	0.180
20	28	0166 18 28	42	0.177
	25	0166 20 25	41	0.168
	22	0166 22 28	42	0.168

ØD1: tube to be fitted

ØD2: for a x mm fitting

Each of the above part numbers comprises:

- a reduction piece
- an olive, PN 0124
- a sleeve nut

# Complementary Brass Compression Fittings

## 0124 Brass Olive

Brass

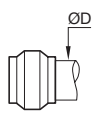

ØD		Kg
4	<a href="#">0124 04 00</a>	0.001
5	<a href="#">0124 05 00</a>	0.001
6	<a href="#">0124 06 00</a>	0.001
8	<a href="#">0124 08 00</a>	0.001
10	<a href="#">0124 10 00</a>	0.003
12	<a href="#">0124 12 00</a>	0.004
14	<a href="#">0124 14 00</a>	0.005
15	<a href="#">0124 15 00</a>	0.004
16	<a href="#">0124 16 00</a>	0.006
18	<a href="#">0124 18 00</a>	0.007
20	<a href="#">0124 20 00</a>	0.009
22	<a href="#">0124 22 00</a>	0.012
25	<a href="#">0124 25 00</a>	0.017
28	<a href="#">0124 28 00</a>	0.017

## 0124..40 Steel Olive

Zinc-plated steel

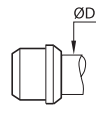

ØD		Kg
4	<a href="#">0124 04 00 40</a>	0.001
6	<a href="#">0124 06 00 40</a>	0.001
8	<a href="#">0124 08 00 40</a>	0.001
10	<a href="#">0124 10 00 40</a>	0.003
12	<a href="#">0124 12 00 40</a>	0.003
14	<a href="#">0124 14 00 40</a>	0.005
15	<a href="#">0124 15 00 40</a>	0.004
16	<a href="#">0124 16 00 40</a>	0.006
18	<a href="#">0124 18 00 40</a>	0.007
20	<a href="#">0124 20 00 40</a>	0.008
22	<a href="#">0124 22 00 40</a>	0.010
25	<a href="#">0124 25 00 40</a>	0.014

## 0111 BNA\* Brass Olive

Brass

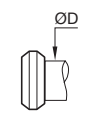

ØD		Kg
4	<a href="#">0111 04 00</a>	0.001
5	<a href="#">0111 05 00</a>	0.001
6	<a href="#">0111 06 00</a>	0.001
8	<a href="#">0111 08 00</a>	0.001
10	<a href="#">0111 10 00</a>	0.002
12	<a href="#">0111 12 00</a>	0.002
14	<a href="#">0111 14 00</a>	0.002
15	<a href="#">0111 15 00</a>	0.003
16	<a href="#">0111 16 00</a>	0.003

\*Bureau de Normalisation de l'Automobile

### Related Products

Parker also offers another type of brass compression fitting: **Metrulok**, with a one-piece olive/nut. Do not hesitate to contact us.



Brass Compression Fittings

Compression Fittings

# Complementary Brass Compression Fittings

## 0110 Brass Nut

Brass

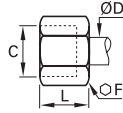

ØD	C		F	L	Kg
4	M8x1	<a href="#">0110 04 00</a>	10	11	0.005
5	M10x1	<a href="#">0110 05 00</a>	12	11	0.006
6	M10x1	<a href="#">0110 06 00</a>	13	11	0.008
8	M12x1	<a href="#">0110 08 00</a>	14	13	0.009
10	M16x1.5	<a href="#">0110 10 00</a>	19	15	0.018
12	M18x1.5	<a href="#">0110 12 00</a>	22	15	0.026
14	M20x1.5	<a href="#">0110 14 00</a>	24	15	0.029
15	M20x1.5	<a href="#">0110 15 00</a>	24	15	0.029
16	M22x1.5	<a href="#">0110 16 00</a>	27	17	0.042
18	M24x1.5	<a href="#">0110 18 00</a>	30	18	0.055
20	M27x1.5	<a href="#">0110 20 00</a>	32	18	0.057
22	M30x1.5	<a href="#">0110 22 00</a>	36	19	0.080
25	M33x1.5	<a href="#">0110 25 00</a>	41	21	0.121
28	M36x1.5	<a href="#">0110 28 00</a>	42	21	0.108

## 0110..40 Steel Nut

Zinc-plated steel

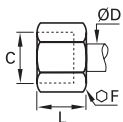

ØD	C		F	L	Kg
4	M8x1	<a href="#">0110 04 00 40</a>	10	11	0.004
5	M10x1	<a href="#">0110 05 00 40</a>	12	11.5	0.006
6	M10x1	<a href="#">0110 06 00 40</a>	13	12	0.008
8	M12x1	<a href="#">0110 08 00 40</a>	14	13.5	0.008
10	M16x1.5	<a href="#">0110 10 00 40</a>	19	16	0.018
12	M18x1.5	<a href="#">0110 12 00 40</a>	22	16.5	0.026
14	M20x1.5	<a href="#">0110 14 00 40</a>	24	17	0.030
15	M20x1.5	<a href="#">0110 15 00 40</a>	24	17	0.030
16	M22x1.5	<a href="#">0110 16 00 40</a>	27	18	0.043
18	M24x1.5	<a href="#">0110 18 00 40</a>	30	19	0.057
20	M27x1.5	<a href="#">0110 20 00 40</a>	32	20.5	0.061
22	M30x1.5	<a href="#">0110 22 00 40</a>	36	21.5	0.085

## 0110..60 Brass Long Nut

Brass

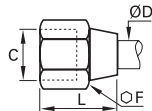

ØD	C		F	L	Kg
4	M8x1	<a href="#">0110 04 00 60</a>	11	14.5	0.007
5	M10x1	<a href="#">0110 05 00 60</a>	13	17	0.008
6	M10x1	<a href="#">0110 06 00 60</a>	13	17.5	0.011
8	M12x1	<a href="#">0110 08 00 60</a>	16	20	0.019
10	M16x1.5	<a href="#">0110 10 00 60</a>	20	23	0.032
12	M18x1.5	<a href="#">0110 12 00 60</a>	22	25	0.039
14	M20x1.5	<a href="#">0110 14 00 60</a>	24	30	0.051
15	M20x1.5	<a href="#">0110 15 00 60</a>	24	30	0.049
18	M24x1.5	<a href="#">0110 18 00 60</a>	30	35	0.098
20	M27x1.5	<a href="#">0110 20 00 60</a>	32	35	0.102
22	M30x1.5	<a href="#">0110 22 00 60</a>	36	36	0.129

## 0110..70 Technical Polymer Nut-Olive

Technical polymer

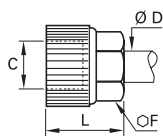

ØD	C		F	L	Kg
4	M8x1	<a href="#">0110 04 00 70</a>	8	13	0.008
6	M10x1	<a href="#">0110 06 00 70</a>	11	15	0.002
8	M12x1	<a href="#">0110 08 00 70</a>	13	16	0.002
10	M16x1.5	<a href="#">0110 10 00 70</a>	17	19	0.004
12	M18x1.5	<a href="#">0110 12 00 70</a>	19	19	0.005
14	M20x1.5	<a href="#">0110 14 00 70</a>	22	20	0.005

NB: polymer nut-olives should not be used on metal tubes.



HANLEY CONTROLS

CLONMEL

[www.hccl.ie](http://www.hccl.ie)



Brass Compression Fittings

Compression Fittings

# Self-Fastening Barb Connectors for NBR Hose

This range of fittings is designed to meet the requirements of the automotive and robotics industries, combining as it does **optimum CNOMO manufacturing quality**, simple installation, reliable operation and a **long service life**.

## Product Advantages

- Perfect for Self-Fastening NBR Hose**
  - Quick and simple to install
  - Compatible with the Parker Legris range of brass compression fittings
  - Mechanical properties proven for use in industrial robotic installations
  - Spark-resistant
- Ergonomic and Time-Saving**
  - Fitting does not require lubrication or clamping, reducing assembly time
  - Visual stop confirms installation is correct and improves operating safety
  - Removal by cutting the tube
  - The fitting can be re-used if necessary



- Welding Robots  
 Pneumatics  
 Compressed Air Systems  
 Automotive Process  
 Cooling
- Applications**

## Technical Characteristics

<b>Compatible Fluids</b>	Coolants, compressed air						
<b>Working Pressure</b>	0 to 16 bar						
<b>Working Temperature</b>	0°C to +100°C (water) -20°C to +70°C (air)						
<b>Tightening Torque, Type 0132</b>	DN	6	8	10	14	18	22
	daN.m	0.7	1.5	1.8	3.5	6	7

### Component Materials

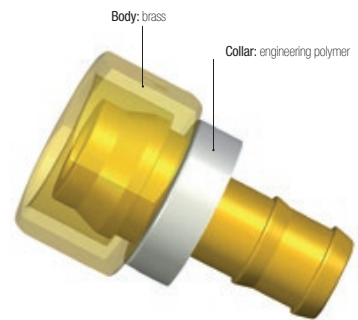

Reliable performance is dependent upon the type of fluid conveyed and hose being used.

**Silicone-free**

### Self-Fastening Hose Assembly Machine

Machine designed to assemble a barb connector and a self-fastening NBR hose.  
Machine part number: **0650 00 00 05**



#### Tube Cutting and Positioning

Cut the hose square and position the barb connector on the mounting tool.

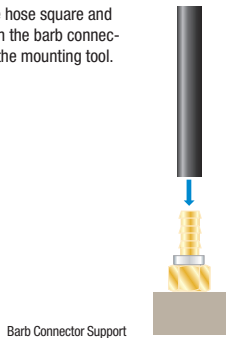

#### Press-Fitting the Tube

Activate the press-fit tool; connection is complete when the tube is fully home on the barb connector. This tool has been designed for use with 5 different diameters and is easy to operate.



### Regulations

**Industrial**  
 DI: 2002/95/EC (RoHS), 2011/65/EC  
 DI: 97/23/EC (PED)  
 RG: 1907/2006 (REACH)  
 CNOMO: E07.21.115N

# Self-Fastening Barb Connectors for NBR Hose

## 0132 Self-Fastening Barb Connector for Brass Compression Fitting

Brass

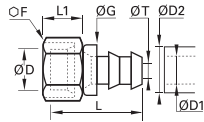



ØD	ØD1	ØD2		F	G	L	L1	ØT	Kg
6	6.3	13	<a href="#">0132 06 56</a>	12	16.5	32.5	12.5	4.8	0.010
8	6.3	13	<a href="#">0132 08 56</a>	14	16.5	29.5	11.5	4.8	0.015
			<a href="#">0132 10 56</a>	19	16.5	30	14	4.8	0.028
10	9.5	16	<a href="#">0132 10 60</a>	19	19.5	34	14	7.5	0.030
			<a href="#">0132 14 60</a>	24	19.5	35.5	15	7.5	0.050
14	12.7	19	<a href="#">0132 14 62</a>	24	23.5	39.5	15	10	0.054
			<a href="#">0132 18 62</a>	30	23.5	41.5	17	10	0.090
18	15.9	23	<a href="#">0132 18 66</a>	30	27	50	17	13.5	0.090
			<a href="#">0132 22 69</a>	36	30.5	56.5	17	16	0.128

Polymer collar

## 0133..39 Self-Fastening Bar Connector with Bi-Material Seal, Male BSPP Thread

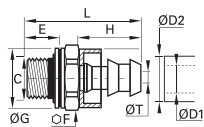
Brass, zinc-plated steel with NBR seal



ØD1	ØD2	C		E	F	G	H	L	ØT	Kg
6.3	13	G1/8	<a href="#">0133 56 10 39</a>	5.5	13	14	20	31.5	4.8	0.012
			<a href="#">0133 56 13 39</a>	7	17	17	20	33.5	4.8	0.018
9.5	16	G1/4	<a href="#">0133 60 13 39</a>	7	17	17	24	37.5	7.5	0.021
			<a href="#">0133 60 17 39</a>	9.5	22	22	24	42.5	7.5	0.038
12.7	19	G3/8	<a href="#">0133 62 17 39</a>	9.5	22	22	28	46.5	10	0.044
			<a href="#">0133 62 21 39</a>	10.5	27	26	28	48.5	10	0.060
15.9	23	G1/2	<a href="#">0133 66 21 39</a>	10.5	27	26	36.5	57	13.5	0.063
			<a href="#">0133 66 27 39</a>	11.5	32	32	36.5	59	13.5	0.096
19.1	27	G3/4	<a href="#">0133 69 27 39</a>	11.5	32	32	43	65.5	16	0.111

Thread with bi-material seal and polymer collar

Bi-material sealing washers part number 0139 can be found in chapter 9.

## 0134 Self-Fastening Barb Connector, Male BSPT Thread

Brass

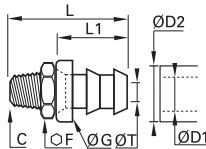

ØD1	ØD2	C		F	G	L	L1	ØT	Kg
6.3	13	R1/8	<a href="#">0134 56 10</a>	14	16.5	32.5	20	4.8	0.015
		R1/4	<a href="#">0134 56 13</a>	14	16.5	37	20	4.8	0.020
9.5	16	R1/4	<a href="#">0134 60 13</a>	14	19.5	41	24	7.5	0.022
		R3/8	<a href="#">0134 60 17</a>	19	19.5	41.5	24	7.5	0.036
12.7	19	R3/8	<a href="#">0134 62 17</a>	19	23.5	45.5	28	10	0.038
		R1/2	<a href="#">0134 62 21</a>	22	23.5	50	28	10	0.062
15.9	23	R1/2	<a href="#">0134 66 21</a>	22	27	58.5	36.5	13.5	0.056
		R3/4	<a href="#">0134 66 27</a>	27	27	60.5	36.5	13.5	0.101
19.1	27	R3/4	<a href="#">0134 69 27</a>	27	30.5	67	43	16	0.108

Polymer collar

Self-fastening NBR hose is selected by nominal diameter; for example:

Barb Connector	O.D. (Tube)	Ø DN (Tube)	Self-Fastening NBR hose
<b>0132 10 56</b>	<b>10</b>	<b>1/4</b>	<b>10..H 56...</b>



# Brass Adaptors

## 0122 Barb Connector for Hose

Brass

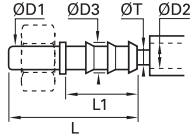

ØD1	ØD2		ØD3	L	L1	ØT min	Kg
4	4	0122 04 04	6	37.5	22.5	3	0.004
5	4	0122 05 04	6	37.5	22.5	3	0.003
6	4	0122 06 04	6	37.5	22.5	3	0.005
	7	0122 06 07	9	37.5	22.5	6	0.007
8	6	0122 08 06	8	40	22.5	5	0.007
	7	0122 08 07	9	40	22.5	6	0.008
10	10	0122 08 10	12.5	40	22.5	9	0.012
	7	0122 10 07	9	43	22.5	6	0.010
12	10	0122 10 10	12.5	43	22.5	9	0.014
	13	0122 12 13	15	50	29.5	12	0.018
14	13	0122 14 13	15	52	29.5	12	0.019
	16	0122 14 16	18.5	60.5	38	15	0.031
15	13	0122 15 13	15	52	29.5	12	0.020
	16	0122 15 16	18.5	60.5	38	15	0.032
16	13	0122 16 13	15	53.5	29.5	12	0.021
	16	0122 16 16	18.5	62	38	15	0.032
18	16	0122 18 16	18.5	62	38	15	0.032
	19	0122 18 19	21.5	62	38	18	0.040
20	16	0122 20 16	18.5	64	38	15	0.034
	19	0122 20 19	21.5	64	38	18	0.039
22	19	0122 22 19	21.5	64	38	18	0.041
	19	0122 25 19	21.5	70	38	18	0.048
25	25	0122 25 25	27.5	70	38	24	0.054
	28	0122 28 25	27.5	70	38	24	0.087

## 0165 Barb Connector for Flexible Tubing

Brass

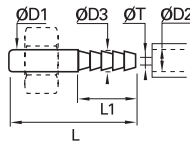

ØD1	ØD2		ØD3	L	L1	ØT min	Kg
4	4	0165 04 06	4.3	30	15	2	0.002
5	4	0165 05 06	4.3	30	15	2	0.003
	4	0165 06 06	4.3	30	15	2	0.003
6	6	0165 06 08	6.4	30	15	4	0.004
	8	0165 06 10	8.4	30	15	4	0.004
8	6	0165 08 08	6.4	32.5	15	4	0.005
	8	0165 08 10	8.4	32.5	15	6	0.006
10	10	0165 08 12	10.7	37.5	20	8	0.009
	8	0165 10 10	8.4	35.5	15	6	0.008
12	10	0165 10 12	10.7	40.5	20	8	0.010
	12	0165 10 14	12.7	40.5	20	8	0.012
14	10	0165 12 12	10.7	40.5	20	8	0.011
	12	0165 12 14	12.7	40.5	20	10	0.012
15	12	0165 14 14	12.7	42.5	20	10	0.015
	13	0165 15 16	13.7	42.5	20	11	0.015
16	13	0165 16 16	13.7	44	20	11	0.018

### Assembly: Barb Connectors

Our barb connectors 0122 and 0165 are designed to be used with different types of hose. They are secured using the nut and olive provided with the fitting.

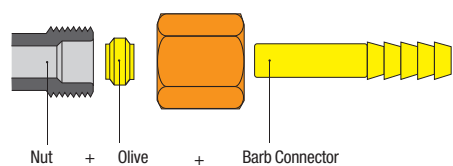

# Brass Adaptors

## 0126 Plug for Compression Fitting

Brass

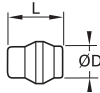

ØD		L	Kg
4	<a href="#">0126 04 00</a>	10	0.002
5	<a href="#">0126 05 00</a>	10	0.003
6	<a href="#">0126 06 00</a>	10	0.003
8	<a href="#">0126 08 00</a>	11.5	0.006
10	<a href="#">0126 10 00</a>	13	0.010
12	<a href="#">0126 12 00</a>	13	0.014
14	<a href="#">0126 14 00</a>	13.5	0.020
15	<a href="#">0126 15 00</a>	13.5	0.022
16	<a href="#">0126 16 00</a>	16	0.030
18	<a href="#">0126 18 00</a>	16	0.038
20	<a href="#">0126 20 00</a>	16	0.045
22	<a href="#">0126 22 00</a>	18	0.003
28	<a href="#">0126 28 00</a>	19.5	0.108

The plug is used to blank off an outlet in a compression fitting, replacing the olive.

When an open outlet is required, simply dismantle and replace the plug with the tube olive, reusing the nut. The plug is also reusable.

## 0125 Tube End Plug for Compression Fitting

Brass

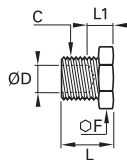

ØD	C		F	L	L1	Kg
4	M8x1	<a href="#">0125 04 00</a>	10	12	8	0.006
6	M10x1	<a href="#">0125 06 00</a>	11	13.5	9.5	0.008
8	M12x1	<a href="#">0125 08 00</a>	14	14	9	0.012
10	M16x1.5	<a href="#">0125 10 00</a>	17	18	11	0.025
12	M18x1.5	<a href="#">0125 12 00</a>	19	18	11	0.030
14	M20x1.5	<a href="#">0125 14 00</a>	22	19	11	0.041

This plug enables unused tubes to be blanked off.

The male thread on the plug has the same pitch as the female thread on the sleeve nut of a standard Parker Legris fitting.

Therefore the plug screwed into the sleeve nut blanks off the tube.

To reopen the passage, simply unscrew the plug and fit the required coupler.

No further treatment of the tube is required.

## 0220 Hex Head Plug, Male BSPP and Metric Thread

Brass, technical polymer

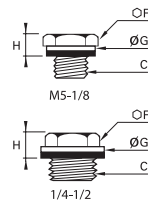

C		F	G	H1	Kg
M5x0.8	<a href="#">0220 19 00</a>	8	8	5	0.002
G1/8	<a href="#">0220 10 00</a>	14	14	7.5	0.011
G1/4	<a href="#">0220 13 00</a>	17	17	7.5	0.020
G3/8	<a href="#">0220 17 00</a>	17	22	8.5	0.024
G1/2	<a href="#">0220 21 00</a>	22	27	10	0.041

Thread with pre-assembled sealing washer

M5: with screwdriver slot for tightening

Maximum allowable working pressure = 20 bar

Part number with suffix 99, maximum allowable working pressure = 250 bar, example: 0220 19 00 99

Conforms to BNA 229 (with the exception of M5 model), BSPP thread, ISO ISO 228-1,

Parallel metric thread, ISO NFE 03-054

## 0220..39 Hex Head Plug with Bi-Material Seal, Male BSPP Thread

Brass, zinc-plated steel with NBR seal

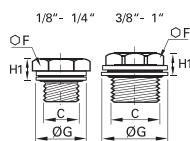

C		F	G	H	Kg
G1/8	<a href="#">0220 10 00 39</a>	14	14	6.5	0.012
G1/4	<a href="#">0220 13 00 39</a>	17	17	6.5	0.020
G3/8	<a href="#">0220 17 00 39</a>	17	22	8	0.025
G1/2	<a href="#">0220 21 00 39</a>	22	26	9	0.043
G3/4	<a href="#">0220 27 00 39</a>	22	32	10	0.060
G1	<a href="#">0220 34 00 39</a>	27	39.5	10.5	0.089

Plug with bi-material seal

Bi-material washers part number 0139 can be found in chapter 9.

# Brass Adaptors

## 0120 Stud Standpipe, Male BSPT Thread

Brass

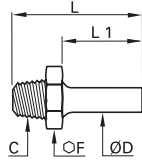

ØD	C		F	L	L1	Kg
4	R1/8	<a href="#">0120 04 10</a>	11	25.5	14	0.007
5	R1/8	<a href="#">0120 05 10</a>	11	26	14.5	0.007
6	R1/8	<a href="#">0120 06 10</a>	11	26.5	15	0.008
	R1/4	<a href="#">0120 06 13</a>	14	31	15	0.015
8	R1/8	<a href="#">0120 08 10</a>	11	28.5	17	0.009
	R1/4	<a href="#">0120 08 13</a>	14	33	17	0.016
	R3/8	<a href="#">0120 08 17</a>	17	33.5	17	0.020
10	R1/4	<a href="#">0120 10 13</a>	14	36	20	0.018
	R3/8	<a href="#">0120 10 17</a>	17	36.5	20	0.022
	R1/2	<a href="#">0120 10 21</a>	22	41	20	0.040
12	R1/4	<a href="#">0120 12 13</a>	14	36	20	0.018
	R3/8	<a href="#">0120 12 17</a>	17	36.5	20	0.022
	R1/2	<a href="#">0120 12 21</a>	22	41	20	0.040
14	R3/8	<a href="#">0120 14 17</a>	17	38	21.5	0.023
	R1/2	<a href="#">0120 14 21</a>	22	42.5	21.5	0.041
15	R3/8	<a href="#">0120 15 17</a>	17	38	21.5	0.023
	R1/2	<a href="#">0120 15 21</a>	22	42.5	21.5	0.041
16	R3/8	<a href="#">0120 16 17</a>	17	39.5	23	0.024
	R1/2	<a href="#">0120 16 21</a>	22	44	23	0.042
18	R1/2	<a href="#">0120 18 21</a>	22	44.5	23.5	0.042
	R3/4	<a href="#">0120 18 27</a>	27	47.5	23.5	0.071
20	R3/4	<a href="#">0120 20 27</a>	27	49	25	0.070
	R3/4	<a href="#">0120 22 27</a>	27	48.5	25.5	0.067
22	R1	<a href="#">0120 22 34</a>	36	52.5	25.5	0.117
25	R1	<a href="#">0120 25 34</a>	36	57	30	0.118
28	R1	<a href="#">0120 28 34</a>	36	57	30	0.140

## 0112 Sleeve Nut for Compression Fitting, Male Metric Thread

Brass

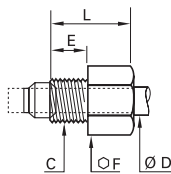

ØD	C		E	F	L	Kg
4	M8x1	<a href="#">0112 04 00</a>	7	10	13	0.005
5	M10x1	<a href="#">0112 05 00</a>	7.5	11	13.5	0.007
6	M10x1	<a href="#">0112 06 00</a>	7.5	11	13.5	0.006
8	M12x1	<a href="#">0112 08 00</a>	8	13	15	0.009
10	M16x1.5	<a href="#">0112 10 00</a>	11	17	18	0.018
12	M18x1.5	<a href="#">0112 12 00</a>	11	19	18	0.021
14	M20x1.5	<a href="#">0112 14 00</a>	11	22	18	0.026

This product was designed to allow the tube to be fitted directly into the tapped port in a body using a standard Parker Legris olive.

For the corresponding drawings (cavity for Parker Legris olive), please consult us.

# Brass Adaptors

## 0128..39 Stud Standpipe with Bi-Material Seal, Male BSPP Thread

Brass, zinc-plated steel with NBR seal

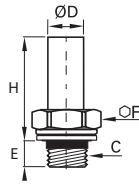

ØD	C		E	F	H	Kg
4	G1/8	0128 04 10 39	7.5	13	20	0.009
	G1/4	0128 04 13 39	9	17	22	0.015
6	G1/8	0128 06 10 39	7.5	13	21	0.010
	G1/4	0128 06 13 39	9	17	23	0.016
8	G1/8	0128 08 10 39	7.5	13	23	0.011
	G1/4	0128 08 13 39	9	17	25	0.017
	G3/8	0128 08 17 39	12	22	26	0.032
10	G1/4	0128 10 13 39	9	17	28	0.018
	G3/8	0128 10 17 39	12	22	29	0.034
	G1/2	0128 10 21 39	27	27	30	0.049
14	G3/8	0128 14 17 39	12	22	30.5	0.035
	G1/2	0128 14 21 39	27	27	31.5	0.049
18	G1/2	0128 18 21 39	27	27	33.5	0.051
	G3/4	0128 18 27 39	14	32	34.5	0.084
22	G3/4	0128 22 27 39	14	32	36.5	0.082
	G1	0128 22 34 39	16.5	41	38	0.123
28	G1	0128 28 34 39	16.5	41	42.5	0.147

With bi-material seal. Bi-material washers part number 0139 can be found in Chapter 9.

## 0151..39 Straight Male Orientable Adaptor, with Bi-Material Seal, Male BSPP Thread

Brass, NBR, zinc-plated steel with NBR seal

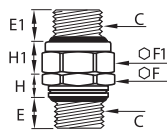

C		E	E1	F	F1	H	H1	Kg
G1/8	0151 10 10 39	5.5	7	13	14	6	6.5	0.017
G1/4	0151 13 13 39	7	8.5	17	19	6.5	9	0.036
G3/8	0151 17 17 39	9.5	9.5	22	22	9	9	0.056
G1/2	0151 21 21 39	10.5	10.5	27	27	10	10	0.083
G3/4	0151 27 27 39	11.5	11.5	32	32	11	10	0.121
G1	0151 34 34 39	13	13.5	41	41	12.5	10.5	0.217

With bi-material seal.

Bi-material washers part number 0139 can be found in Chapter 9.

## 0168..39 Reducer, with Bi-Material Seal, Male BSPP Thread/Female BSPP and Metric Thread

Brass, zinc-plated steel with NBR seal

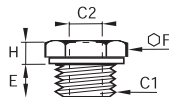

C1	C2		E	F	H	Kg
G1/8	M5x0.8	0168 10 19 39	8	14	4.5	0.009
	M5x0.8	0168 13 19 39	8	17	5	0.018
G1/4	G1/8	0168 13 10 39	8	17	5	0.012
	G1/8	0168 17 10 39	10	19	5	0.020
G3/8	G1/4	0168 17 13 39	10	19	5	0.013
	G1/8	0168 21 10 39	12	24	7.5	0.052
G1/2	G1/4	0168 21 13 39	12	24	7.5	0.044
	G3/8	0168 21 17 39	12	24	7.5	0.031
G3/4	G1/4	0168 27 13 39	12	32	9.5	0.100
	G3/8	0168 27 17 39	12	32	9.5	0.086
	G1/2	0168 27 21 39	12	32	9.5	0.065

With bi-material seal.

Bi-material washers part number 0139 can be found in Chapter 9.

# Brass Adaptors

## 0127 Brass Tube Support for Polymer Tubing

Brass

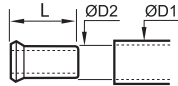

ØD1	ØD2		L	Kg
4	2	0127 04 00	11	0.001
	2.7	0127 04 27	11	0.001
5	3	0127 05 03	11	0.001
	3.3	0127 05 00	11.5	0.009
6	4	0127 06 00	11.5	0.001
	5.5	0127 08 55	14	0.001
8	6	0127 08 00	14	0.001
	7	0127 10 07	18	0.001
10	7.5	0127 10 75	18	0.001
	8	0127 10 00	18	0.002
12	8	0127 12 08	18	0.002
	9	0127 12 09	18	0.002
14	10	0127 12 00	18	0.001
	11	0127 14 11	18	0.002
15	12	0127 14 00	18	0.002
	12	0127 15 12	18	0.002
16	13	0127 16 13	18	0.003
18	14	0127 18 14	19.5	0.003
20	15	0127 20 15	20.5	0.003
22	16	0127 22 16	21	0.004
25	19	0127 25 19	25	0.007

This tube support guarantees good gripping, at high temperatures and pressures, by preventing collapsing of the tube.

# Stainless Steel Compression Fitting Range

## Stainless Steel Fittings

### Stud Fittings

- |                                  |                                 |                                  |                                  |                                 |                                  |                                 |
|----------------------------------|---------------------------------|----------------------------------|----------------------------------|---------------------------------|----------------------------------|---------------------------------|
| <b>1805</b><br>BSPT<br>Page 5-34 | <b>1805</b><br>NPT<br>Page 5-34 | <b>1814</b><br>BSPP<br>Page 5-34 | <b>1809</b><br>BSPT<br>Page 5-35 | <b>1809</b><br>NPT<br>Page 5-35 | <b>1820</b><br>BSPT<br>Page 5-35 | <b>1820</b><br>NPT<br>Page 5-35 |
|----------------------------------|---------------------------------|----------------------------------|----------------------------------|---------------------------------|----------------------------------|---------------------------------|



### Tube-to-Tube Fittings

- |                          |                          |                          |                          |
|--------------------------|--------------------------|--------------------------|--------------------------|
| <b>1806</b><br>Page 5-36 | <b>1816</b><br>Page 5-36 | <b>1802</b><br>Page 5-36 | <b>1804</b><br>Page 5-36 |
|--------------------------|--------------------------|--------------------------|--------------------------|



### Complementary Fittings

- |                          |                          |                          |
|--------------------------|--------------------------|--------------------------|
| <b>1866</b><br>Page 5-39 | <b>1824</b><br>Page 5-39 | <b>1810</b><br>Page 5-39 |
|--------------------------|--------------------------|--------------------------|



### Accessories

- |                          |                          |
|--------------------------|--------------------------|
| <b>1822</b><br>Page 5-39 | <b>1827</b><br>Page 5-39 |
|--------------------------|--------------------------|



Stainless Steel  
Compression Fittings

Compression Fittings

# Stainless Steel Compression Fittings

**Manufactured in 316L stainless steel**, these fittings combine all the advantages of the "universal" compression fitting with **excellent resistance** to environmental conditions and **corrosive fluids**. They are pressure and temperature-resistant and are able to withstand strong vibration and water hammer.

## Product Advantages

### For Use in Many Environments

Manufactured in 316L stainless steel  
Suitable for all environments and fluids  
Resistant to water hammer and vibration  
Excellent sealing and retention of the tube  
Suitable for pneumatic and medium pressure hydraulic applications  
Metallic sealing guarantees maximum service life

### Many Tube Options

Possibility of easily connecting different tube materials and diameters to the same fitting body  
No tube support required for rigid and semi-rigid polyamide tubing below 12 mm



**Applications**

- Food Process
- Fluid Transmission
- Pneumatics
- Automotive Process
- Petrochemical
- Chemical
- Offshore Oil & Gas

## Technical Characteristics

<b>Compatible Fluids</b>	Many fluids				
<b>Working Pressure</b>	Vacuum to 400 bar (80 bar in corrosive environments)				
<b>Working Temperature</b>	-60°C to +250°C with metal tubing				

<b>Tightening Torques</b>	DN	6	8	10	12	16
	daN.m	2	3	4	6.5	9.5

Reliable performance is dependent upon the type of fluid conveyed and tubing being used. Guaranteed for use with a vacuum of 755 mm Hg (99% vacuum). Thread sealing must be guaranteed by user.

### Component Materials

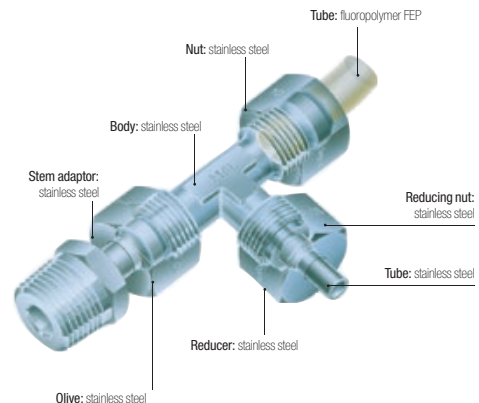

**Silicone-free**

### Maximum Bore Diameters

The table below shows the recommended compatibility of tube size, BSPP male thread and maximum bore.

Tube O.D	BSPP Thread	Max. Bore
6	G1/8	4
6-8-10	G1/4	7
10-12	G3/8	11
16	G1/2	14

### Tube Length for Assembly

Minimum length of tube (L) between 2 fittings.



ØD	L mm	ØD	L mm
4	26.5	10	39
6	26	12	39
8	32	16	46.5

### Regulations

DI: 2002/95/EC (RoHS), 2011/65/EC  
DI: 97/23/EC (PED)  
RG: 1935/2004  
RG: 1907/2006 (REACH)  
DI: 94/09/EC (ATEX)  
FDA: 21 CFR 177.1550  
NACE MR0175: compatible materials  
ISO 15156-1/-2/-3: compatible materials

# Stainless Steel Compression Fittings

## Installation

Fitting	Orientable Elbow Assembly	Customised Fittings
---------	---------------------------	---------------------

The fitting comprises three parts (body/olive/nut). For assembly procedure, please see Brass Compression Fitting page.

Elbow  
**1802**

Adaptor  
**1820**

If our standard range does not meet your needs, Parker Legris can develop customised solutions for your applications.

**Diagram: Assembled Fitting**

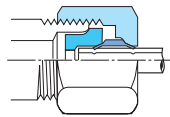

A very slight distortion of the tube appears; this shows the fitting has been correctly tightened.

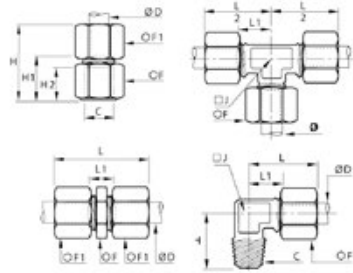
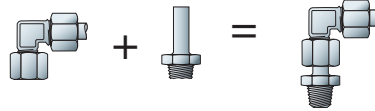

## Technical Characteristics

The use of Parker Legris stainless steel compression fittings is dependant on the tube material. Tables of recommended working pressure for the different tubes are shown below.

### Recommended Tube Type

**Semi-rigid polyamide or fluoropolymer tube**

**Stainless steel tube**

"Thin Wall" cold-drawn seamless, annealed and passivated:  
 wall thickness tolerance +/-0.1 mm.  
 For use with "thin wall" stainless steel tube from 6 mm to 16 mm O.D.,  
 maximum wall thickness 1 mm.

### Recommended Tube/Fitting Assembly Configurations

Assembled using Parker Legris olive and nut in stainless steel, with a tube support.

**Stainless steel tube**

Stainless steel tube: in cold-rolled straight lengths  
 Coiled annealed stainless tube: reduces working pressure by 35%; do not use if there is vibration.

**Semi-Rigid Polyamide Tube**

Maximum Working Pressure (bar)

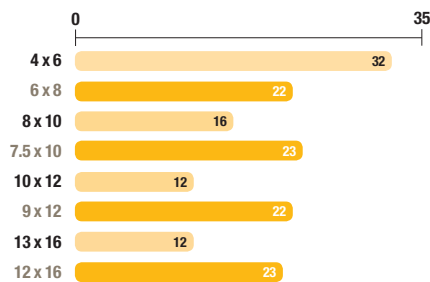

**Stainless Steel Tube**

Maximum Working Pressure (bar)

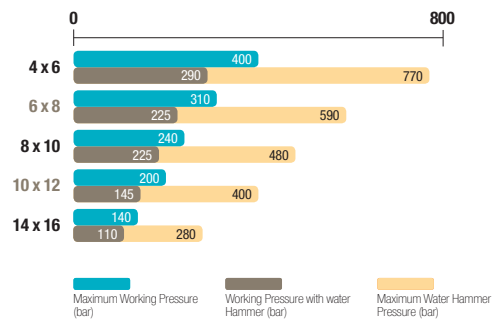

### Working Pressure Coefficients for Semi-Rigid Tubing

Temperature °C	-40°C / -15°C	-15°C / +30°C	+30°C / +50°C	+50°C / +70°C	+70°C / +100°C
Factor	1.8	1	0.68	0.55	0.31

The above recommendations are given in good faith. However, since each application is different, it is advisable to undertake tests in actual working conditions.

# Stainless Steel Compression Fittings

## 1805 Stud Fitting, Male BSPT Thread

Stainless steel 316L

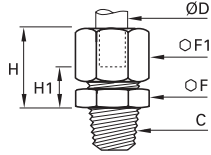

ØD	C		F	F1	H <sub>max</sub>	H1	Kg
6	R1/8	<a href="#">1805 06 10</a>	12	13	19.5	7.5	0.017
	R1/4	<a href="#">1805 06 13</a>	14	13	19.5	7.5	0.024
8	R1/8	<a href="#">1805 08 10</a>	13	14	21	7	0.019
	R1/4	<a href="#">1805 08 13</a>	14	14	21	7	0.025
10	R1/4	<a href="#">1805 10 13</a>	17	19	25.5	9	0.043
	R3/8	<a href="#">1805 10 17</a>	17	19	25.5	9	0.049
	R1/2	<a href="#">1805 10 21</a>	22	19	26.5	10	0.077
12	R1/4	<a href="#">1805 12 13</a>	19	22	26	9	0.054
	R3/8	<a href="#">1805 12 17</a>	19	22	26	9	0.057
	R1/2	<a href="#">1805 12 21</a>	22	22	27	10	0.081
16	R3/8	<a href="#">1805 16 17</a>	24	27	28.5	9.5	0.085
	R1/2	<a href="#">1805 16 21</a>	24	27	28.5	9.5	0.095

## 1805 Stud Fitting, Male NPT Thread

Stainless steel 316L

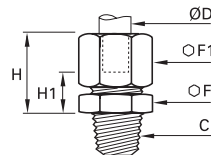

ØD	C		F	F1	H <sub>max</sub>	H1	Kg
6	NPT1/8	<a href="#">1805 06 11</a>	12	13	19.5	7.5	0.018
	NPT1/4	<a href="#">1805 06 14</a>	14	13	19.5	7.5	0.027
	NPT3/8	<a href="#">1805 06 18</a>	19	13	20.5	8.5	0.033
	NPT1/2	<a href="#">1805 06 22</a>	22	13	21.5	9.5	0.049
8	NPT1/8	<a href="#">1805 08 11</a>	13	14	21	7	0.020
	NPT1/4	<a href="#">1805 08 14</a>	14	14	21	7	0.027
	NPT1/4	<a href="#">1805 10 14</a>	17	19	25.5	9	0.046
10	NPT3/8	<a href="#">1805 10 18</a>	19	19	25.5	9	0.055
	NPT1/2	<a href="#">1805 10 22</a>	22	19	26.5	10	0.081
12	NPT1/4	<a href="#">1805 12 14</a>	19	22	26	9	0.056
	NPT3/8	<a href="#">1805 12 18</a>	19	22	26	9	0.060
	NPT1/2	<a href="#">1805 12 22</a>	22	22	27	10	0.087
16	NPT3/8	<a href="#">1805 16 18</a>	24	27	28.5	9.5	0.087
	NPT1/2	<a href="#">1805 16 22</a>	24	27	28.5	9.5	0.097

## 1814 Stud Fitting, Female BSPP Thread

Stainless steel 316L

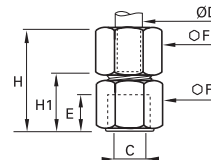

ØD	C		E	F	F1	H <sub>max</sub>	H1	Kg
6	G1/8	<a href="#">1814 06 10</a>	7.5	14	13	29	17	0.023
	G1/4	<a href="#">1814 06 13</a>	11	17	13	29	21	0.032
8	G1/4	<a href="#">1814 08 13</a>	11	17	14	34.5	20.5	0.033
10	G3/8	<a href="#">1814 10 17</a>	11.5	22	19	38.5	22	0.064
	G1/2	<a href="#">1814 10 21</a>	15	27	19	43	26.5	0.094
12	G3/8	<a href="#">1814 12 17</a>	11.5	22	22	39	22	0.073
	G1/2	<a href="#">1814 12 21</a>	15	27	22	43.5	26.5	0.103
16	G1/2	<a href="#">1814 16 21</a>	15	27	27	45	26	0.121

# Stainless Steel Compression Fittings

## 1809 Stud Elbow, Male BSPT Thread

Stainless steel 316L

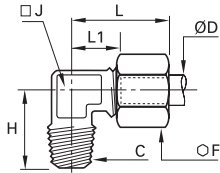

ØD	C		F	H	J	L <sub>max</sub>	L1	Kg
6	R1/8	<a href="#">1809 06 10</a>	13	18	8	25.5	13.5	0.020
	R1/4	<a href="#">1809 06 13</a>	13	23	10	25.5	13.5	0.029
8	R1/8	<a href="#">1809 08 10</a>	14	20.5	10	28.5	14.5	0.026
	R1/4	<a href="#">1809 08 13</a>	14	23	10	28.5	14.5	0.030
10	R1/4	<a href="#">1809 10 13</a>	19	25	12	32.5	16	0.050
	R3/8	<a href="#">1809 10 17</a>	19	25.5	12	32.5	16	0.058
	R1/2	<a href="#">1809 10 21</a>	19	32	18	36.5	20	0.093
	R1/4	<a href="#">1809 12 13</a>	22	26	14	34	17	0.067
12	R3/8	<a href="#">1809 12 17</a>	22	27	14	34	17	0.069
	R1/2	<a href="#">1809 12 21</a>	22	32	18	37	20	0.100
16	R3/8	<a href="#">1809 16 17</a>	27	28.5	18	39.5	21	0.108
	R1/2	<a href="#">1809 16 21</a>	27	31.5	18	39.5	21	0.115

## 1809 Stud Elbow, Male NPT Thread

Stainless steel 316L

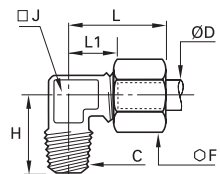

ØD	C		F	H	J	L <sub>max</sub>	L1	Kg
6	NPT1/8	<a href="#">1809 06 11</a>	13	19.5	8	25.5	13.5	0.021
	NPT1/4	<a href="#">1809 06 14</a>	13	25.5	10	25.5	13.5	0.032
	NPT3/8	<a href="#">1809 06 18</a>	13	28	12	27	15	0.046
	NPT1/2	<a href="#">1809 06 22</a>	13	34	12	29	17	0.071
8	NPT1/8	<a href="#">1809 08 11</a>	14	22	10	28.5	14.5	0.027
	NPT1/4	<a href="#">1809 08 14</a>	14	25.5	10	28.5	14.5	0.033
10	NPT1/4	<a href="#">1809 10 14</a>	19	27.5	12	32.5	16	0.052
	NPT3/8	<a href="#">1809 10 18</a>	19	28	12	32.5	16	0.062
	NPT1/2	<a href="#">1809 10 22</a>	19	35	18	36.5	20	0.096
	NPT1/4	<a href="#">1809 12 14</a>	22	28.5	14	34	17	0.068
12	NPT3/8	<a href="#">1809 12 18</a>	22	29.5	14	34	17	0.073
	NPT1/2	<a href="#">1809 12 22</a>	22	35	18	37	20	0.104
16	NPT3/8	<a href="#">1809 16 18</a>	27	31	18	39.5	21	0.110
	NPT1/2	<a href="#">1809 16 22</a>	27	34.5	18	39.5	21	0.116

## 1820 Stud Standpipe, Male BSPT Thread

Stainless steel 316L

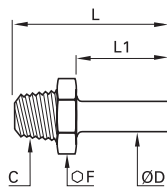

ØD	C		F	L	L1	Kg
6	R1/8	<a href="#">1820 06 10</a>	12	26.5	15	0.009
	R1/4	<a href="#">1820 06 13</a>	14	31	15	0.018
8	R1/8	<a href="#">1820 08 10</a>	12	28.5	17	0.008
	R1/4	<a href="#">1820 08 13</a>	14	33	17	0.017
10	R1/4	<a href="#">1820 10 13</a>	14	36	20	0.017
	R3/8	<a href="#">1820 10 17</a>	17	36.5	20	0.025
	R1/2	<a href="#">1820 10 21</a>	22	41	20	0.053
	R1/4	<a href="#">1820 12 13</a>	14	36	20	0.016
12	R3/8	<a href="#">1820 12 17</a>	17	36.5	20	0.022
	R1/2	<a href="#">1820 12 21</a>	22	41	20	0.049
16	R3/8	<a href="#">1820 16 17</a>	17	39.5	23	0.022
	R1/2	<a href="#">1820 16 21</a>	22	44	23	0.039

## 1820 Stud Standpipe, Male NPT Thread

Stainless steel 316L

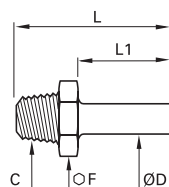

ØD	C		F	L	L1	Kg
6	NPT1/8	<a href="#">1820 06 11</a>	12	26.5	15	0.010
	NPT1/4	<a href="#">1820 06 14</a>	14	31	15	0.019
8	NPT1/8	<a href="#">1820 08 11</a>	12	28.5	17	0.009
	NPT1/4	<a href="#">1820 08 14</a>	14	33	17	0.019
10	NPT1/4	<a href="#">1820 10 14</a>	14	36	20	0.018
	NPT3/8	<a href="#">1820 10 18</a>	19	36.5	20	0.032
	NPT1/2	<a href="#">1820 10 22</a>	22	41	20	0.060
	NPT1/4	<a href="#">1820 12 14</a>	14	36	20	0.019
12	NPT3/8	<a href="#">1820 12 18</a>	19	36.5	20	0.028
	NPT1/2	<a href="#">1820 12 22</a>	22	41	20	0.053
16	NPT3/8	<a href="#">1820 16 18</a>	19	39.5	23	0.027
	NPT1/2	<a href="#">1820 16 22</a>	22	44	23	0.042

# Stainless Steel Compression Fittings

## 1806 Equal Tube-to-Tube Connector

Stainless steel 316L

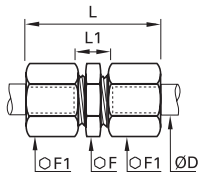

ØD		F	F1	L <sub>max</sub>	L1	Kg
6	<a href="#">1806 06 00</a>	12	13	34.5	11	0.024
8	<a href="#">1806 08 00</a>	13	14	38.5	10	0.029
10	<a href="#">1806 10 00</a>	17	19	46	13	0.066
12	<a href="#">1806 12 00</a>	19	22	47	13	0.085
16	<a href="#">1806 16 00</a>	24	27	51	13	0.136

## 1816 Equal Bulkhead Connector

Stainless steel 316L

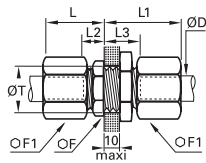

ØD		F	F1	L <sub>max</sub>	L1 <sub>max</sub>	L2	L3	ØT <sub>min</sub>	Kg
6	<a href="#">1816 06 00</a>	13	13	28	19	7.5	17	10.5	0.035
8	<a href="#">1816 08 00</a>	14	14	29	20	7	17	12.5	0.042
10	<a href="#">1816 10 00</a>	19	19	33	25	9	19	16.5	0.093
12	<a href="#">1816 12 00</a>	22	22	33	25	9	19	18.5	0.113
16	<a href="#">1816 16 00</a>	27	27	36	28	9.5	19.5	22.5	0.179

## 1802 Equal Elbow

Stainless steel 316L

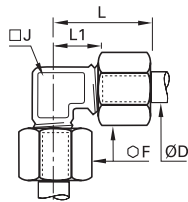

ØD		F	J	L <sub>max</sub>	L1	Kg
6	<a href="#">1802 06 00</a>	13	8	25.5	13.5	0.027
8	<a href="#">1802 08 00</a>	14	10	28.5	14.5	0.035
10	<a href="#">1802 10 00</a>	19	12	32.5	16	0.069
12	<a href="#">1802 12 00</a>	22	14	34	17	0.093
16	<a href="#">1802 16 00</a>	27	18	39.5	21	0.152

## 1804 Equal Tee

Stainless steel 316L

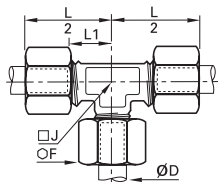

ØD		F	J	L1	L/2	Kg
6	<a href="#">1804 06 00</a>	13	8	13.5	25.5	0.039
8	<a href="#">1804 08 00</a>	14	10	14.5	28.5	0.049
10	<a href="#">1804 10 00</a>	19	12	16	32.5	0.102
12	<a href="#">1804 12 00</a>	22	14	17	34	0.132
16	<a href="#">1804 16 00</a>	27	18	21	39.5	0.215



**HANLEY CONTROLS**

CLOMEL

[www.hccl.ie](http://www.hccl.ie)

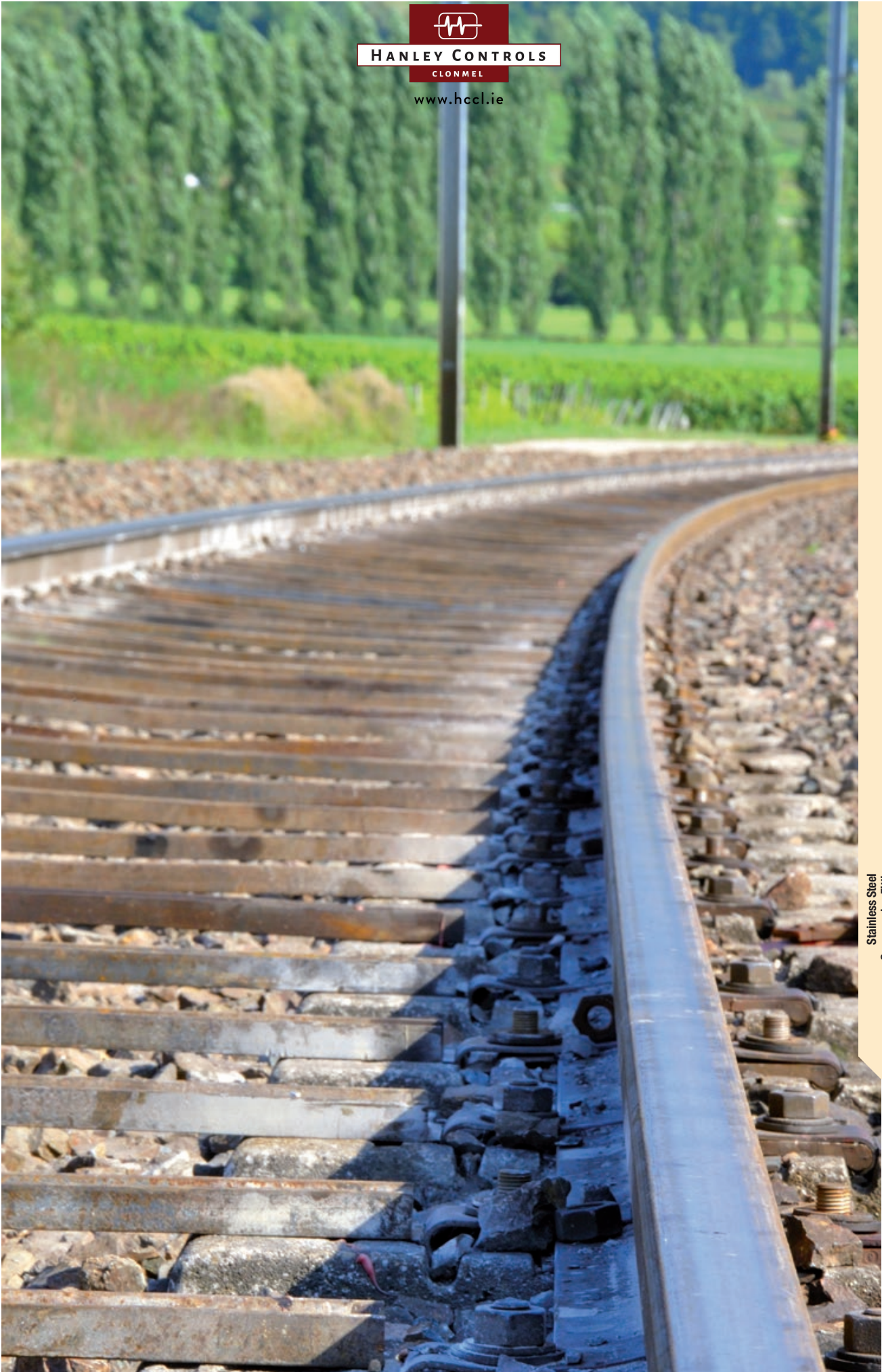

Stainless Steel  
Compression Fittings

Compression Fittings

# Complementary Stainless Steel Fittings

## Reducers, Olives and Nuts

This innovative reducer system, using a full range of nuts and olives, enables **different diameters** of stainless steel, fluoropolymer or polymer tubes to be fitted onto a **single Parker Legris compression fitting**.

### Product Advantages



- |                              |   |
|------------------------------|---|
| <b>Efficient Solution</b>    | <ul style="list-style-type: none"> <li>Reduces envelope dimensions</li> <li>Quick and easy to assemble, whatever the diameters and tube material</li> <li>Improved stock management</li> <li>Silicone-free</li> </ul>   |
| <b>Multiple Combinations</b> | <p>A single connector for up to 3 different tube materials and sizes.</p> <p>Example:</p> <ul style="list-style-type: none"> <li>• Advanced PE tubing 6 mm O.D.</li> <li>• stainless steel tubing 8 mm O.D.</li> <li>• fluoropolymer tubing 12 mm O.D. or braided PVC hose 10 mm I.D.</li> </ul> <p>A full range of olives and nuts to optimise all assembly operations</p> |



- Food Process  
 Fluid Transmission  
 Pneumatics  
 Automotive Process  
 Petrochemical  
 Cooling & Heating  
 Chemical  
 Offshore Oil & Gas

Applications

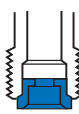
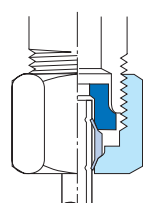
### Reducer Assembly Procedure

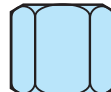
Operation	Assembly Sequence	Assembled Fitting
<p><b>1</b></p> <p><b>Assemble the reducer</b> Place the reducer in the fitting body.</p>	<p><b>1</b></p> 	
<p><b>2</b></p> <p><b>Assemble the nut and olive</b> Place the nut and then the olive onto the tube.</p>	<p><b>2</b></p> 	
<p><b>3</b></p> <p><b>Assemble the nut</b> Push the tube into the fitting until it bottoms on the reducer. Tighten the nut to the recommended torque (see opposite page).</p>	<p><b>3</b></p> 	

### Assembly: Barb Connectors

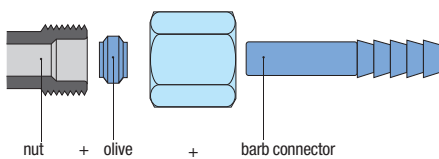

#### Regulations

- DI: 2002/95/EC (RoHS), 2011/65/EC
- DI: 97/23/EC (PED)
- RG: 1935/2004
- RG: 1907/2006 (REACH)
- DI: 94/09/EC (ATEX)
- FDA: 21 CFR 177.1550
- NACE MR0175: compatible materials
- ISO 15156-1/-2/-3: compatible materials

Our barb connector 1822 is designed to be also used with different types of hose. It is secured using the nut and olive provided with the fitting.

# Stainless Steel Compression Fittings

## 1866 3-Piece Reducer

Stainless steel 316L

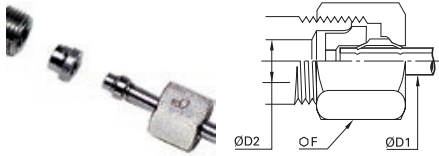

ØD1	ØD2		F	Kg
	8	<a href="#">1866 06 08</a>	14	0.011
6	10	<a href="#">1866 06 10</a>	19	0.027
	12	<a href="#">1866 06 12</a>	22	0.040
8	10	<a href="#">1866 08 10</a>	19	0.025
	12	<a href="#">1866 08 12</a>	22	0.037
10	16	<a href="#">1866 08 16</a>	27	0.071
	12	<a href="#">1866 10 12</a>	22	0.034
12	16	<a href="#">1866 10 16</a>	27	0.065
	16	<a href="#">1866 12 16</a>	27	0.061

## 1824 Stainless Steel Olive

Stainless steel 316L



ØD		Kg
6	<a href="#">1824 06 00</a>	0.001
8	<a href="#">1824 08 00</a>	0.001
10	<a href="#">1824 10 00</a>	0.003
12	<a href="#">1824 12 00</a>	0.004
16	<a href="#">1824 16 00</a>	0.005

## 1810 Stainless Steel Nut

Stainless steel 316L



ØD	C		F	L	Kg
6	M10x1	<a href="#">1810 06 00</a>	13	11	0.007
8	M12x1	<a href="#">1810 08 00</a>	14	13	0.008
10	M16x1.5	<a href="#">1810 10 00</a>	19	15	0.017
12	M18x1.5	<a href="#">1810 12 00</a>	22	15	0.024
16	M22x1.5	<a href="#">1810 16 00</a>	27	17	0.041

## 1822 Barb Adaptor for Hose

Stainless steel 316L

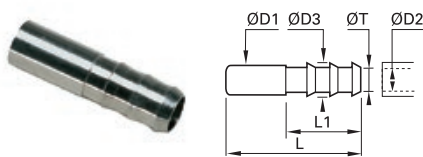

ØD1	ØD2		ØD3	L	L1	ØT min	Kg
6	7	<a href="#">1822 06 07</a>	9	37.5	22.5	6	0.006
	6	<a href="#">1822 08 06</a>	8	40	22.5	5	0.007
8	7	<a href="#">1822 08 07</a>	9	40	22.5	6	0.007
	10	<a href="#">1822 08 10</a>	12.5	40	22.5	9	0.011
10	7	<a href="#">1822 10 07</a>	9	43	22.5	6	0.009
	10	<a href="#">1822 10 10</a>	12.5	43	22.5	9	0.013
12	10	<a href="#">1822 12 10</a>	12.2	43	22.5	9	0.012
	13	<a href="#">1822 12 13</a>	15	50	29.5	13	0.016

## 1827 Stainless Steel Tube Support for Fluoropolymer Tubing

Stainless steel 316L

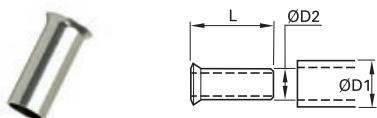

ØD1	ØD2		L	Kg
6	4	<a href="#">1827 06 00</a>	11.5	0.001
8	6	<a href="#">1827 08 00</a>	14	0.001
10	8	<a href="#">1827 10 00</a>	18	0.001
12	9	<a href="#">1827 12 09</a>	18	0.001
	10	<a href="#">1827 12 00</a>	18	0.001
16	14	<a href="#">1827 16 00</a>	18	0.002

This tube support is necessary when using fluoropolymer tubing at all temperatures compatible with the fitting/tubing assembly.

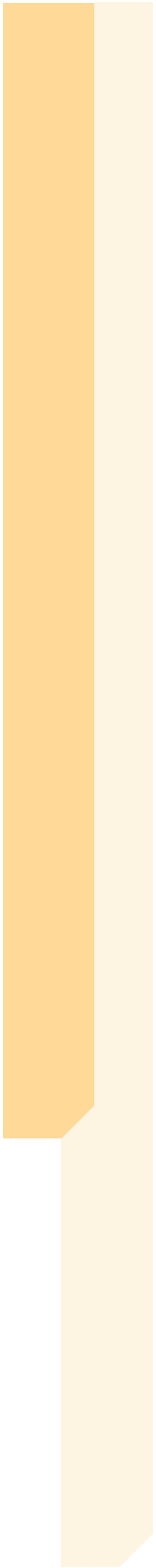

# PL Nickel-Plated Brass Spigot Fitting Range

## Stud Fittings

### Straights

- F3BPL**  
BSPT  
Page 5-43
- F3BPL-1**  
BSPT  
Page 5-43
- F4BPL**  
BSPP  
Page 5-43
- F8BPL**  
Metric  
Page 5-43
- F8BPL-1**  
Metric  
Page 5-43



### Elbows

- C3BPL**  
BSPT  
Page 5-44
- C3BPL-1**  
BSPT  
Page 5-44
- C4BPL**  
BSPP  
Page 5-44
- C8BPL**  
Metric  
Page 5-44



### Tees

- R3BPL**  
BSPT  
Page 5-45
- S3BPL**  
BSPT  
Page 5-45



## Banjo Fitting

### Banjo Fitting

- COR4BPL**  
BSPP  
Page 5-45



## Tube-to-Tube Fittings

### Straights

- HBPL**  
Union  
Page 5-46
- HBPL-1**  
Union  
Page 5-46



### Tees

- JBPL**  
Union  
Page 5-46
- JBPL-1**  
Union  
Page 5-46



### Bulkhead Connectors

- WBPL**  
Page 5-47
- WBPL-1**  
Page 5-47



## Complementary Fittings

- BPLM**  
Nut  
Page 5-47
- BPLM-M**  
Nut  
Page 5-47
- 0164**  
NPT/BSPP  
Page 5-47



# PL Nickel-Plated Brass Spigot Fittings

This range of Parker Legris has a sealing system which guarantees **excellent sealing and full flow**. PL fittings for flexible tubing are **fully re-usable**. They provide excellent compatibility with a wide variety of fluids.

## Product Advantages

- Rapid Assembly** | Nut design allows for easy tightening  
 Quick to assemble and disassemble  
 Compatible with flexible and semi-rigid tubes (polyurethane, polyamide, polyethylene, fluoropolymers, etc.)  
 Mechanical stop on the body to prevent overtightening
- Performance** | Reliable direct sealing system without the use of a seal or olive  
 Low pressure  
 Nickel-plated for increased corrosion resistance



- Applications**
- Food Process
  - Painting
  - Pneumatic Systems
  - Chemical
  - Welding
  - Laboratories
  - Railway

## Technical Characteristics

<b>Compatible Fluids</b>	Compressed air Other fluids: contact us					
<b>Working Pressure</b>	Vacuum to 18 bar with BPLM-M nut Vacuum to 40 bar with BPLM nut					
<b>Working Temperature</b>	-40°C to +100°C					
<b>Tightening Torque (Nm)</b>	M5x0.8	M6x1	1/8	1/4	3/8	1/2
<b>BSPT Thread</b>			8	12	14	16
<b>BSPP Thread with "O" ring</b>			1.2	1.5	2.5	3.5
<b>BSPP Thread with metal sleeve</b>			5	8	10	12
<b>Metric Thread</b>	0.8	0.8				



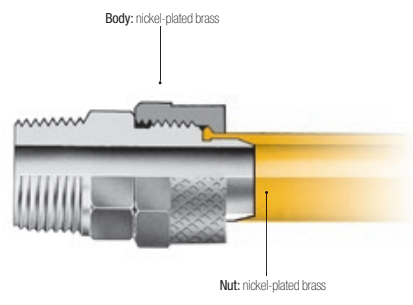

### Component Materials



**Silicone-free**

Reliable performance is dependent upon the type of fluid conveyed, component materials and tubing being used.  
 Guaranteed for use with a vacuum of 755 mm Hg (99% vacuum).  
 For use with fire-proof tubing; please consult us.

## Installation

Cutting the Tube	Preparing the Connection	Connecting the Tube	Final Assembly
 <p>Cut the polymer tube square.</p>	 <p>Slide the nut onto the tube.</p>	 <p>Push the tube home into the body of the fitting.</p>	 <p>Tighten the nut by hand (in the case of soft tubing) or using a spanner (for semi-rigid tubing) until it comes into contact with the end stop.</p>

# Stud Fittings

## F3BPL Stud Fitting, Male BSPT Thread

Nickel-plated brass

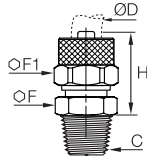

ØD	C		F	F1	H	Kg
2.7x4	R1/8	<a href="#">F3BPL2.7/4-1/8</a>	12	8	24	0.009
4x6	R1/8	<a href="#">F3BPL4/6-1/8</a>	12	12	27.5	0.016
	R1/4	<a href="#">F3BPL4/6-1/4</a>	14	12	31	0.025
6x8	R1/8	<a href="#">F3BPL6/8-1/8</a>	12	14	27.5	0.019
	R1/4	<a href="#">F3BPL6/8-1/4</a>	14	14	31	0.026
	R3/8	<a href="#">F3BPL6/8-3/8</a>	17	14	31.5	0.030
8x10	R1/4	<a href="#">F3BPL8/10-1/4</a>	14	16	32.5	0.031
	R3/8	<a href="#">F3BPL8/10-3/8</a>	17	16	33	0.043
10x12	R3/8	<a href="#">F3BPL10/12-3/8</a>	17	18	34.5	0.036

Compatible with BPLM-M nut only

## F3BPL-1 Stud Fitting, Male BSPT Thread

Nickel-plated brass

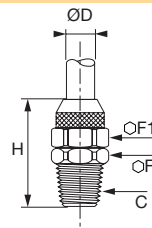

ØD	C		F	F1	H	Kg
7.5x10	R1/4	<a href="#">F3BPL7.5/10-1/4</a>	14	16	27.5	0.031
	R3/8	<a href="#">F3BPL7.5/10-3/8</a>	17	16	28.5	0.037
11x14	R3/8	<a href="#">F3BPL11/14-3/8</a>	19	22	32.5	0.058

Compatible with BPLM nut only  
Maximum working pressure: 40 bar

## F4BPL Stud Fitting, Male BSPP Thread

Nickel-plated brass, NBR

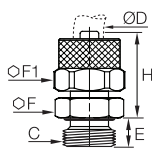

ØD	C		E	F	F1	H	Kg
4x6	G1/8	<a href="#">F4BPL4/6-1/8</a>	6	13	12	25.5	0.031
6x8	G1/4	<a href="#">F4BPL6/8-1/4</a>	8	16	14	28	0.033

Compatible with BPLM-M nut only

## F8BPL Stud Fitting, Male Metric Thread

Nickel-plated brass, NBR

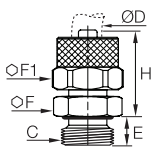

ØD	C		E	F	F1	H	Kg
6x8	M10x1	<a href="#">F8BPL6/8M10</a>	7	14	13	28	0.025

Compatible with BPLM-M nut only

## F8BPL-1 Stud Fitting, Male Metric Thread

Nickel-plated brass, copper

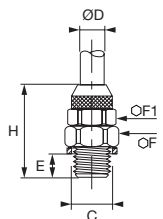

ØD	C		E	F	F1	H	Kg
6x8	M12x1.25	<a href="#">F8BPL6/8M12</a>	8	17	14	28	0.028

Compatible with BPLM nut only  
Maximum working pressure: 40 bar  
These fittings are supplied with a copper seal.

# Stud Fittings

## C3BPL Stud Elbow, Male BSPT Thread

Nickel-plated brass

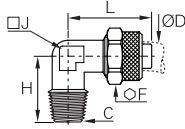

ØD	C		F	H	J	L	Kg
2.7x4	R1/8	<a href="#">C3BPL2.7/4-1/8</a>	8	17	8	19.5	0.018
4x6	R1/8	<a href="#">C3BPL4/6-1/8</a>	12	17	8	22.5	0.022
	R1/4	<a href="#">C3BPL4/6-1/4</a>	12	20	10	22.5	0.031
6x8	R1/8	<a href="#">C3BPL6/8-1/8</a>	14	17	10	22.5	0.029
	R1/4	<a href="#">C3BPL6/8-1/4</a>	14	20	10	22.5	0.031
8x10	R3/8	<a href="#">C3BPL6/8-3/8</a>	14	22.5	11	24	0.064
	R1/4	<a href="#">C3BPL8/10-1/4</a>	16	21.5	11	25.5	0.057
10x12	R3/8	<a href="#">C3BPL8/10-3/8</a>	16	22.5	11	25.5	0.057
	R3/8	<a href="#">C3BPL10/12-3/8</a>	18	24.5	14	30	0.060

Compatible with BPLM-M nut only

## C3BPL-1 Stud Elbow, Male BSPT Thread

Nickel-plated brass

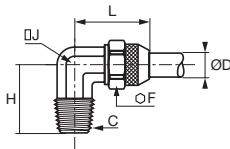

ØD	C		F	H	J	L	Kg
7.5x10	R1/4	<a href="#">C3BPL7.5/10-1/4</a>	16	22.5	12	28	0.057
	R3/8	<a href="#">C3BPL7.5/10-3/8</a>	16	23	12	28	0.058
11x14	R3/8	<a href="#">C3BPL11/14-3/8</a>	22	25	16	34	0.094

Compatible with BPLM nut only

Maximum working pressure: 40 bar

## C4BPL Stud Elbow, Male BSPP Thread

Nickel-plated brass, NBR

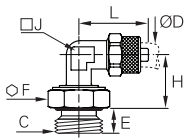

ØD	C		E	F	F1	H	J	L	Kg
6x8	G1/4	<a href="#">C4BPL6/8-1/4</a>	8	17	14	25	10	23.5	0.068

These fittings are supplied with nitrile seals.

Compatible with BPLM-M nut only

## C8BPL-1 Stud Elbow, Male Metric Thread

Nickel-plated brass, NBR

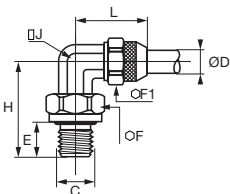

ØD	C		E	F	F1	H	J	L	Kg
6x8	M10x1	<a href="#">C8BPL6/8M10</a>	7	14	13	27	10	22	0.034
	M12x1	<a href="#">C8BPL6/8M12</a>	7	13	13	26	12	25	0.074

These fittings are supplied with nitrile seals.

Compatible with BPLM nut only

Maximum working pressure: 40 bar

# Stud Fittings

## R3BPL Stud Run Tee, Male BSPT Thread

Nickel-plated brass

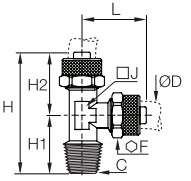

	ØD	C		F	H	H1	H2	J	Kg
4x6	R1/8	<a href="#">R3BPL4/6-1/8</a>		12	39.5	17	22.5	8	0.035
	R1/4	<a href="#">R3BPL4/6-1/4</a>		12	43.5	21	22.5	10	0.048
6x8	R1/8	<a href="#">R3BPL6/8-1/8</a>		14	40.5	18	22.5	10	0.045

Compatible with BPLM-M nut only

## S3BPL Stud Branch Tee, Male BSPT Thread

Nickel-plated brass

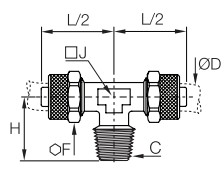

	ØD	C		F	H	J	L2	Kg
4x6	R1/8	<a href="#">S3BPL4/6-1/8</a>		12	17	8	22.5	0.035
	R1/4	<a href="#">S3BPL4/6-1/4</a>		12	20.5	10	22.5	0.047
6x8	R1/8	<a href="#">S3BPL6/8-1/8</a>		14	17.5	10	22.5	0.046

Compatible with BPLM-M nut only

## COR4BPL Single Banjo, Male BSPP Thread

Nickel-plated brass, treated steel, NBR

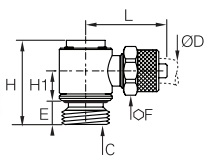

	ØD	C		E	F	H	H1	L	Kg
4x6	G1/8	<a href="#">COR4BPL4/6-1/8</a>		6.5	12	25.5	9	24	0.069
	G1/4	<a href="#">COR4BPL4/6-1/4</a>		8	12	31.5	10	26	0.097
6x8	G1/8	<a href="#">COR4BPL6/8-1/8</a>		6.5	14	25.5	9	24	0.073

These parts are supplied with peripheral seals.

The banjo bolt is made of steel.

Compatible with BPLM-M nut only

# PL Tube-to-Tube and Complementary Fittings

## HBPL Equal Tube-to-Tube Connector

Nickel-plated brass

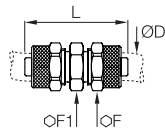

ØD		F	F1	L	Kg
2.7x4	<a href="#">HBPL2.7/4</a>	8	8	26	0.010
4x6	<a href="#">HBPL4/6</a>	12	12	34.5	0.021
6x8	<a href="#">HBPL6/8</a>	14	14	35	0.030
8x10	<a href="#">HBPL8/10</a>	14	16	38	0.043
10x12	<a href="#">HBPL10/12</a>	17	18	41	0.056

Compatible with BPLM-M nut only

## HBPL-1 Equal Tube-to-Tube Connector

Nickel-plated brass

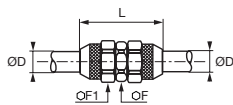

ØD		F	F1	L	Kg
11x14	<a href="#">HBPL11/14</a>	19	22	40	0,087

Compatible with BPLM nut only  
 Maximum working pressure: 40 bar

## JBPL Equal Tee

Nickel-plated brass

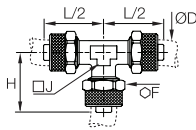



ØD		F	H	J	L2	Kg
2.7x4	<a href="#">JBPL2.7/4</a>	8	20	8	22	0.035
4x6	<a href="#">JBPL4/6</a>	12	22.5	8	22.5	0.042
6x8	<a href="#">JBPL6/8</a>	14	22.5	10	22.5	0.057
8x10	<a href="#">JBPL8/10</a>	16	25.5	11	25.5	0.085
10x12	<a href="#">JBPL10/12</a>	18	30	14	30	0.100

Compatible with BPLM-M nut only

## JBPL-1 Equal Tee

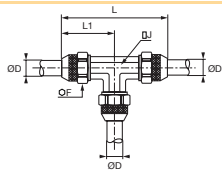
Nickel-plated brass



ØD		F	J	L	L1	Kg
7.5x10	<a href="#">JBPL7.5/10</a>	16	12	56	28	0.086
11x14	<a href="#">JBPL11/14</a>	22	16	68	34	0.168

Compatible with BPLM nut only  
 Maximum working pressure: 40 bar

# PL Tube-to-Tube and Complementary Fittings

## WBPL

### Equal Bulkhead Connector

Nickel-plated brass

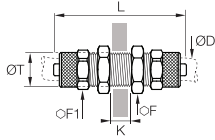

ØD		F	F1	K <sub>max</sub>	L	ØT	Kg
4x6	<a href="#">WBPL4/6</a>	14	12	10.5	48	10	0.030
6x8	<a href="#">WBPL6/8</a>	16	14	10.5	48	12	0.040
8x10	<a href="#">WBPL8/10</a>	17	16	8.5	50	14	0.057
10x12	<a href="#">WBPL10/12</a>	19	18	8.5	53	26	0.064

Compatible with BPLM-M nut only

## WBPL-1

### Equal Bulkhead Connector

Nickel-plated brass

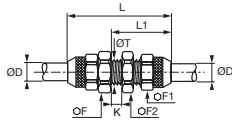

ØD		F	F1	F2	K <sub>max</sub>	L	L1	ØT	Kg
11x14	<a href="#">WBPL11/14</a>	22	22	22	5	50	28	19	0.114

Compatible with BPLM nut only  
 Maximum working pressure: 40 bar.

## BPLM

### Nut

Nickel-plated brass

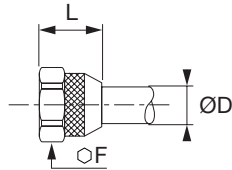

ØD	C		F	L	Kg
6x8	M11x0.75	<a href="#">BPL8M</a>	13	13	0.008
7.5x10	M13x1	<a href="#">BPL10M</a>	16	14	0.014
11x14	M18x1.5	<a href="#">BPL14M</a>	22	18	0.018

Maximum working pressure: 40 bar

## BPLM-M

### Nut

Nickel-plated brass

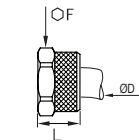



ØD	C		F	L	Kg
2.7x4	M6x0.50	<a href="#">BPL4M-1</a>	8	8	0.003
4x6	M8x0.75	<a href="#">BPL6M-1</a>	9	9	0.006
6x8	M12x1	<a href="#">BPL8M-1</a>	14	10.5	0.008
8x10	M14x1	<a href="#">BPL10M-1</a>	16	11.5	0.012
10x12	M16x1	<a href="#">BPL12M-1</a>	18	13	0.014

## 0164

### Adaptor, Male NPT/Female BSPP Thread

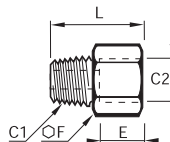
Nickel-plated brass



C1	C2		E	F	L	Kg
NPT1/8	G1/8	<a href="#">0164 11 10 99</a>	7.5	14	20	0.015
NPT1/4	G1/4	<a href="#">0164 14 13 99</a>	11	17	27.5	0.028
NPT3/8	G3/8	<a href="#">0164 18 17 99</a>	11.5	22	28.5	0.044

Maximum working pressure: see page 9-6, brass adaptors.