

# Industrial Valves

## Ball Valves

LIQUIfit®

## Needle and Butterfly Valves

## Axial Valves



**HANLEY CONTROLS**

CLONMEL

[www.hccl.ie](http://www.hccl.ie)



**HANLEY CONTROLS**

CLONMEL

[www.hccl.ie](http://www.hccl.ie)



# Industrial Valves

## Ball Valves, Universal Series

[P. 6-8]



**Fluids:** compressed air, slightly corrosive fluids

**Materials:** nickel-plated forged brass

**Pressure:** 40 bar

**Temperature:** -40°C to +80°C

**(DN)** : 4 mm to 40 mm

## Ball Valves, Universal Series, Vented

[P. 6-13]



**Fluids:** compressed air, slightly corrosive fluids

**Materials:** nickel-plated forged brass

**Pressure:** 40 bar

**Temperature:** -20°C to +80°C

**(DN)** : 4 mm to 23 mm

## Ball Valves, Universal Series, Lockable

[P. 6-15]



**Fluids:** compressed air, slightly corrosive fluids

**Materials:** nickel-plated forged brass, galvanised steel and epoxy locking system

**Pressure:** 40 bar

**Temperature:** -40°C to +80°C

**(DN)** : 4 mm to 23 mm

## Ball Valves, Universal Customised Series

[P. 6-9]



**Fluids:** compressed air, many fluids

**Materials:** nickel-plated forged brass, choice of seal material (NBR, EPDM, FKM, PTFE...)

**Pressure:** 40 bar

**Temperature:** -40°C to +100°C

**(DN)** : 4 mm to 40 mm

## Ball Valves, Universal Light Series

[P. 6-16]



**Fluids:** compressed air, slightly corrosive fluids

**Materials:** forged brass or nickel-plated forged brass

**Pressure:** 12 bar

**Temperature:** -20°C to +80°C

**(DN)** : 4 mm to 13 mm

## Ball Valves, DVGW Series

[P. 6-20]



**Fluids:** compressed air, water, gas

**Materials:** nickel-plated forged brass

**Pressure:** 40 bar

**Temperature:** -50°C to +170°C

**(DN)** : 8 mm to 50 mm

## Ball Valves, Standard Series

[P. 6-22]



**Fluids:** compatible fluids

**Materials:** nickel or chromium-plated brass with PTFE seal

**Pressure:** 35 bar

**Temperature:** -20°C to +130°C

**(DN)** : 8 mm to 100 mm

## Ball Valves, Stainless Steel Series

[P. 6-28]



**Fluids:** all fluids

**Materials:** 316L stainless steel

**Pressure:** 65 bar

**Temperature:** -20°C to +150°C

**(DN)** : 8 mm to 50 mm

## Ball Valves, Stainless Steel Light Series



**Fluids:** all fluids

**Materials:** 316L stainless steel

**Pressure:** 65 bar

**Temperature:** -20°C to +120°C

**(DN)** : 4 mm to 10 mm

# Industrial Valves

## Ball Valves, High Pressure Series

[P. 6-30]



**Fluids:** lubricants, gases  
**Materials:** zinc-plated brass  
**Pressure:** 300 bar  
**Temperature:** -15°C to +80°C  
 $\overline{\text{DN}}$  : 7 mm to 13 mm

## Ball Valves, Mini Series

[P. 6-32]



**Fluids:** compressed air  
**Materials:** technical polymer  
**Pressure:** 10 bar  
**Temperature:** -20°C to +80°C  
 $\overline{\text{DN}}$  : 4 mm to 12 mm

## Ball Valves, LIQUIfit®

[P. 6-34]



**Fluids:** water, beverages, CO<sub>2</sub>, inert gases  
**Materials:** polypropylene, EPDM seal  
**Pressure:** 10 bar  
**Temperature:** -15°C to +100°C  
 $\varnothing$  inch: 1/4" and 3/8"  
 $\varnothing$  metric: 6 mm to 12 mm

## Needle Valves, Brass

[P. 6-37]



**Fluids:** compressed air, industrial fluids  
**Materials:** shot-blasted forged brass, nickel-plated  
**Pressure:** 120 bar  
**Temperature:** -20°C to +100°C  
 $\overline{\text{DN}}$  : 4 mm to 10 mm

## Needle Valves, Stainless Steel

[P. 6-41]



**Fluids:** all fluids  
**Materials:** 316L stainless steel  
**Pressure:** 400 bar  
**Temperature:** -20°C to +180°C  
 $\overline{\text{DN}}$  : 3 mm to 6 mm

## Butterfly Valves

[P. 6-42]



**Fluids:** compressed air, abrasive fluids  
**Materials:** shot-blasted forged brass, nickel-plated  
**Pressure:** 16 bar  
**Temperature:** -20°C to +80°C  
 $\overline{\text{DN}}$  : 6 mm to 18 mm

## Axial Valves

[P. 6-45]



**Fluids:** compressed air, industrial fluids  
**Materials:** nickel-plated brass  
**Pressure:** 10 bar  
**Temperature:** -20°C to +135°C  
**Threads :** 3/8" to 2"

# Ball Valve Range

## Universal and Universal Customised Series

### In-Line

**0402** 2/2 Page 6-10    **0401** 2/2 Page 6-10    **0400** 2/2 Page 6-10    **0411** 2/2 Page 6-10    **0414** 2/2 Page 6-10



### In-Line with Fixing Holes and Panel Mounting

**0446** 2/2 Page 6-11    **6402** 2/2 Page 6-11    **6401** 2/2 Page 6-11



### Right-Angled

**0472** 2/2 Page 6-11    **0471** 2/2 Page 6-11



### In-Line, 3-Way

**0482** 3/3 Page 6-12    **0483** 3/3 Page 6-12



### In-Line, 3-Way with Fixing Holes and Panel Mounting

**0448** 3/3 Page 6-12    **0452** 3/2 Page 6-12



## Universal Series, Vented

### In-Line

**0489** 3/2 Page 6-13    **0449** 3/2 Page 6-13    **0469** 3/2 Page 6-13



### Right-Angled

**0462** 3/2 Page 6-14    **0461** 3/2 Page 6-14



## Universal Lockable Series

### In-Line

**0432** 2/2 Page 6-15



### In-Line, Vented

**0439** 3/2 Page 6-15    **0436** 3/2 Page 6-15    **0437** 3/2 Page 6-15



### In-Line, 3-Way

**0438** 3/2 Page 6-15



## Universal Light Series

### In-Line

**0492** 2/2 Page 6-17    **0491** 2/2 Page 6-17    **0490** 2/2 Page 6-17



### In-Line, Vented

**0494** 2/2 Page 6-18



### In-Line with Square Stem

**0497** 2/2 Page 6-18    **0496** 2/2 Page 6-18



# Ball Valve Range

## DVGW Series

### In-Line

#### BVG4-L

2/2  
Page 6-21



#### BVGT4-L

2/2  
Page 6-21



## Standard Series

### In-Line

#### 4902

2/2  
Page 6-23



#### BVGT4-C

2/2  
Page 6-23



### Compact

#### 4991

2/2  
Page 6-23



#### 4992

2/2  
Page 6-23



### In-Line, Lockable

#### BVG4-LOCK

2/2  
Page 6-24



### In-Line, Lockable, Vented

#### BVG4P-LOCK

3/2  
Page 6-24



## Stainless Steel Series

### In-Line

#### 4832

Mountable and dismountable  
2/2  
Page 6-29



#### 4812

Mountable  
2/2  
Page 6-29



#### 4810

One-Piece Construction  
2/2  
Page 6-29



#### 0465

Light Series  
2/2  
Page 6-29



## High Pressure Series

### In-Line

#### 4402

2/2  
Page 6-31



## Mini Series

### In-Line

#### 7910

2/2  
Page 6-33



#### 7911

2/2  
Page 6-33



### In-Line, Vented and Accessories

#### 7913

3/2  
Page 6-33



#### 7914

3/2  
Page 6-33



#### 7000

Page 6-33



## LIQUIfit®

### In-Line

#### 4020

2/2  
Page 6-35



#### 4020

2/2  
Page 6-35



#### 4021

2/2  
Page 6-35



#### 4023

2/2  
Page 6-35



### Right-Angled

#### 4022

2/2  
Page 6-35



#### 4024

2/2  
Page 6-35



### Accessories

#### 3130

Page 6-35



# Ball Valves, Universal Series

This range of valves has patented **seal wear compensating** technology for **reliable** and **durable** sealing, **protecting** any system whether under pressure or **vacuum**.

## Product Advantages

### Durability & Reliability

- Automatic seal wear compensation for long-term reliability
- Robust, corrosion-resistant materials
- 100% leak-tested in production
- Date coding to guarantee quality and traceability

### Versatility & Performance

- Ideal for ensuring the performance of pneumatic circuits
- Customised valves for all special applications
- Unequalled performance under vacuum
- Smooth operation thanks to self-lubricating seals
- Large range of working pressures and temperatures
- Lever can be repositioned and replaced
- Many configurations to satisfy all system requirements



**Applications**

- Pneumatics
- Vacuum
- Transportation
- Packaging
- Textile
- Sawmill
- Rubber & Plastics

## Technical Characteristics

<b>Compatible Fluids</b>	Industrial fluids						
<b>Working Pressure</b>	Vacuum to 40 bar						
<b>Working Temperature</b>	-40°C to + 80°C						

<b>Tightening Torques</b>	Threads	G1/8	G1/4	G3/8	G1/2	G3/4	G1	
	daN.m	0.10 to 0.20	0.10 to 0.20	0.15 to 0.25	0.20 to 0.35	0.50 to 0.70	0.50 to 0.70	
	Threads	G1¼	G1½	G2				
	daN.m	0.40 to 0.60	0.80 to 1.20	0.80 to 1.20				

Reliable performance is dependent upon the type of fluid conveyed, component materials and tubing being used.  
Guaranteed for use with a vacuum of 755 mm Hg (99 % vacuum).

### Component Materials

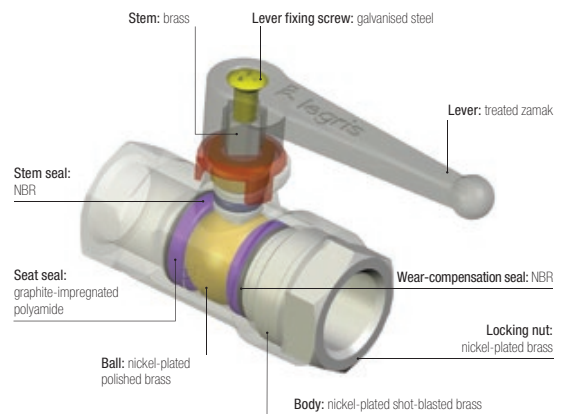

### Silicone-free

### Regulations

- DI: 97/23/EC (module PED A - diameters greater than 25 mm)
- DI: 2006/42/EC (Machinery Directive)
- DI: 2002/95/EC (RoHS)
- RG: 1907/2006 (REACH)

# Universal Series

## Installation Options

### Lockable Valves

Our lockable ball valves have been developed in order to prevent potentially dangerous consequences caused by unintended operation. Lockable in different positions, this range meets international safety requirements, such as ISO 4414.

The valves are lockable:

- at one point: models 0432 and 0439
- at three points: models 0437 and 0438

### Vented Valves

To stop fluid circulation and vent the circuit, 2 venting systems are provided:

- with threaded exhaust, to allow discharge of downstream media
- with pin-hole vent, for applications with no special discharge requirement

Fluid flow direction is indicated by an arrow on the valve body.

### Mountable Valves

On steel plate:

- bulkhead fixing
- complete valve below bulkhead

On frame:

- assemble with bolts

On wooden panel:

- assemble with woodscrews

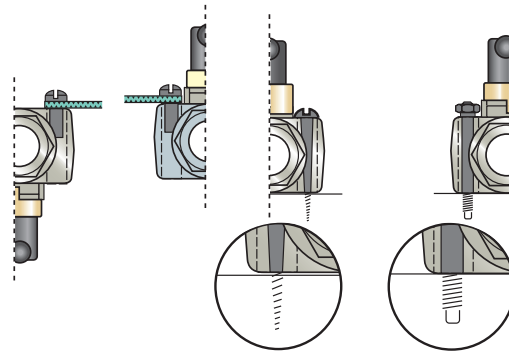

### Universal Customised Valve Series

Based on the standard components of the universal series, this range allows the valve to be adapted to specific needs. There are 6 product versions available on request.

#### Product Codes

Valve type	0402	04	10	22	Suffix
0400	 04 = 4 mm 05 = 5 mm ... 40 = 40 mm	 10 = 1/8" 13 = 1/4" ... 48 = 2"			20 = blue/red 22 = green/blue 26 = yellow/yellow 27 = blue/green 30 = white/red 32 = white/green
0401					
0402					
...					

#### Identification

Each series may be easily identified by a colour marking on the lever.



#### Suffix Specification

Identification		Body		Lever			Ball		Stem and Wear-Compensation Seals			Seat Seals			Application Examples
Suffix on the body	Colour bands on the lever	Nickel-plated brass	Chemical nickel-plated brass	Standard	Nickel-plated brass	Chemical nickel-plated brass	Nickel-plated polished brass	Chemical nickel-plated brass	EPDM	FKM	PTFE white	Rilsan: graphite-impregnated	Filled PTFE	PTFE white	
20		•		•			•			•		•			Hydrocarbons
22		•		•				•		•			•		Industrial fluids and high temperature
26*		•			•			•			• olive			•	Corrosive liquids or high temperature and compatible for use at -50°C
27			•			•		•		•			•		Industrial fluids and/or harsh environments
30**		•		•			•		•			•			Gaseous oxygen circuits
32		•		•				•	•				•		Water and steam circuits

\*degreased \*\*oxygen-compatible grease

A usage chart in this chapter shows which type of valve to use according to the fluid being conveyed.

# Universal Series

## 0402 2/2 In-Line Ball Valve, Female BSPP Thread

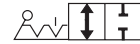

Nickel-plated brass, NBR

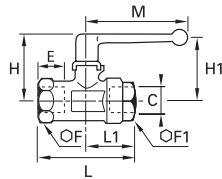

DN	C		E	F	F1	H	H1	L	L1	M	Kg
4	G1/8	0402 04 10	8	-	14	35	29	44	25	48	0.094
7	G1/8	0402 07 10	8	19	19	38	31	51	27	48	0.165
	G1/4	0402 07 13	12	19	19	38	31	53	28	48	0.156
10	G3/8	0402 10 17	12	24	24	45	43	59	31	69	0.244
13	G1/2	0402 13 21	15	27	27	47	44	67	34	69	0.292
20	G3/4	0402 20 27	16.5	32	38	63	54	80	39	108	0.655
	G1	0402 23 34	19	41	46	67	57	94	47	108	1.036
32	G1 1/4	0402 32 42*	21.5	55	60	97	115	112	59	180	2.467
	G1 1/2	0402 32 49*	22	55	60	97	115	120	62	180	2.340
40	G1 1/2	0402 40 49*	22	55	55	104	-	111	55	190	2.445
	G2	0402 40 48*	26	70	70	104	-	122	61	190	2.614

\*Models with EC marking  
 Maximum working pressure: 40 bar

## 0401 2/2 In-Line Ball Valve, Male/Female BSPP Thread



Nickel-plated brass, NBR

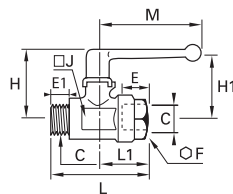

DN	C		E	E1	F	H	H1	J	L	L1	M	Kg
4	G1/8	0401 04 10	8	7	14	35	29	14	45	25	48	0.094
5	G1/8	0401 05 10	8	7	19	38	31	19	51	27	48	0.160
7	G1/4	0401 07 13	12	9	19	38	31	19	52	28	48	0.150
10	G3/8	0401 10 17	12	11	24	45	43	24	58	31	69	0.234
13	G1/2	0401 13 21	15	12	27	47	44	27	66	34	69	0.286
18	G3/4	0401 18 27	16.5	12	38	63	54	39	79	39	108	0.652
23	G1	0401 23 34	19	15	46	67	57	48	91	47	108	0.952
32	G1 1/4	0401 32 42*	21.5	18	60	97	115	55	113	59	108	2.385

\*Models with EC marking  
 Maximum working pressure: 40 bar

## 0400 2/2 In-Line Ball Valve, Male BSPP Thread



Nickel-plated brass, NBR

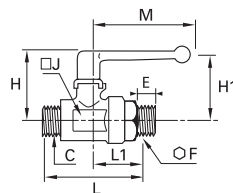

DN	C		E	F	H	H1	J	L	L1	M	Kg
4	G1/8	0400 04 10	7	14	35	29	14	45	25	48	0.094
7	G1/4	0400 07 13	9	19	38	31	19	60	36	48	0.166
10	G3/8	0400 10 17	11	24	45	43	24	70	43	69	0.252
13	G1/2	0400 13 21	12	27	47	44	27	78	45	69	0.324
18	G3/4	0400 18 27	12	38	63	54	39	90	50	108	0.714

Maximum working pressure: 40 bar

## 0411 2/2 In-Line Ball Valve with Connections for Use with Steel Tube



Nickel-plated brass, NBR

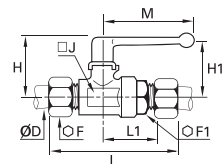

DN	ØD		F	F1	H	H1	J	L	L1	M	Kg
4	6	0411 04 06	14	19	38	31	19	76	30	48	0.173
6	8	0411 06 08	17	19	38	31	19	77	30	48	0.195
7	10	0411 07 10	19	19	38	31	19	78	31	48	0.210
10	12	0411 10 12	22	24	45	43	24	85	36	69	0.310

Maximum working pressure: 40 bar

## 0414 2/2 In-Line Ball Valve with Compression Connections



Nickel-plated brass, NBR

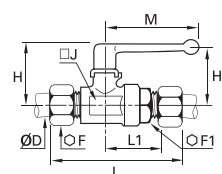

DN	ØD		F	F1	H	H1	J	L	L1	M	Kg
4	6	0414 04 06	13	19	38	31	19	72	31	48	0.177
6	8	0414 06 08	14	19	38	31	19	74	30	48	0.180
7	10	0414 07 10	19	19	38	31	19	78	31	48	0.210
10	12	0414 10 12	22	24	45	43	24	86	36	69	0.308

Maximum working pressure: 40 bar

# Universal Series

## 0446 2/2 In-Line Panel-Mountable Ball Valve, Female BSPP Thread



Nickel-plated brass, NBR

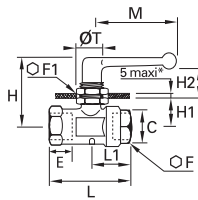

DN	C		E	F	F1	H	H1	H2	L	L1	M	ØT	Kg
4	G1/8	<a href="#">0446 04 10</a>	8	14	22	37	14	12	44	25	48	16.5	0.112
7	G1/4	<a href="#">0446 07 13</a>	12	19	24	45	19	14	53	28	48	20.5	0.188
10	G3/8	<a href="#">0446 10 17</a>	12	24	27	50	21	21	59	31	69	20.5	0.294
13	G1/2	<a href="#">0446 13 21</a>	15	27	27	51	23	21	67	34	69	20.5	0.338

Maximum working pressure: 20 bar

\*For G1/8 version, maximum panel thickness = 3 mm

## 6402 2/2 In-Line Ball Valve for Screw Fixing, Female BSPP Thread



Nickel-plated brass, NBR

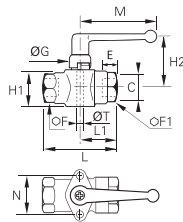

DN	C		E	F	F1	G	H1	H2	L	L1	M	N	ØT	Kg
4	G1/8	<a href="#">6402 04 10</a>	8	14	14	18	18	30	44	25	48	25	4x70	0.132
7	G1/4	<a href="#">6402 07 13</a>	12	19	19	19	24	31	53	28	48	31	5x80	0.216
10	G3/8	<a href="#">6402 10 17</a>	12	24	24	20	30	45	59	31	69	31	5x80	0.324
13	G1/2	<a href="#">6402 13 21</a>	15	27	27	20	34	47	67	34	69	34	6x100	0.404
20	G3/4	<a href="#">6402 20 27</a>	16.5	32	38	27	44	52	80	39	108	43	8x125	0.830
23	G1	<a href="#">6402 23 34</a>	19	41	46	27	53	56	94	47	108	51	8x125	1.290

Maximum working pressure: 40 bar

## 6401 2/2 In-Line Ball Valve for Screw Fixing, Male/Female BSPP Thread



Nickel-plated brass, NBR

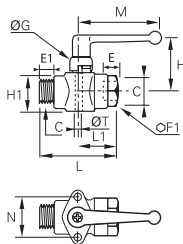

DN	C		E	E1	F	G	H1	H2	L	L1	M	N	ØT	Kg
4	G1/8	<a href="#">6401 04 10</a>	8	7	14	18	18	30	45	25	48	25	4x70	0.127
7	G1/4	<a href="#">6401 07 13</a>	12	9	19	19	24	31	52	28	48	31	5x80	0.212
10	G3/8	<a href="#">6401 10 17</a>	12	11	24	20	30	45	58	31	69	31	5x80	0.306
13	G1/2	<a href="#">6401 13 21</a>	15	12	27	20	34	47	67	34	69	34	6x100	0.394

Maximum working pressure: 40 bar

## 0472 2/2 Right-Angled Ball Valve, Female BSPP Thread



Nickel-plated brass, NBR

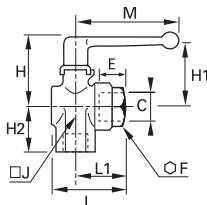

DN	C		E	F	H	H1	H2	J	L	L1	M	Kg
4	G1/8	<a href="#">0472 04 10</a>	8	14	35	29	18	14	34	25	48	0.096
6	G1/8	<a href="#">0472 06 10</a>	8	19	38	31	20	22	37	27	48	0.183
	G1/4	<a href="#">0472 06 13</a>	12	19	38	31	24	22	38	28	48	0.191
9	G3/8	<a href="#">0472 09 17</a>	12	24	45	43	27	25	46	31	69	0.260
12	G1/2	<a href="#">0472 12 21</a>	15	27	47	44	33	29	49	34	69	0.312
18	G3/4	<a href="#">0472 18 27</a>	16.5	38	59	51	40	39	60	39	108	0.704
23	G1	<a href="#">0472 23 34</a>	19	46	63	55	47	48	72	47	108	1.062

Maximum working pressure: 20 bar

## 0471 2/2 Right-Angled Ball Valve, Male/Female BSPP Thread



Nickel-plated brass, NBR

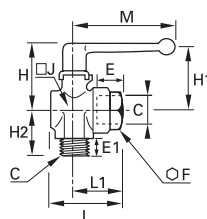

DN	C		E	E1	F	H	H1	H2	J	L	L1	M	Kg
4	G1/8	<a href="#">0471 04 10</a>	8	7	14	35	29	19	14	34	25	48	0.096
6	G1/8	<a href="#">0471 06 10</a>	8	7	19	38	31	22	22	37	27	48	0.182
	G1/4	<a href="#">0471 06 13</a>	12	9	19	38	31	25	22	38	28	48	0.187
9	G3/8	<a href="#">0471 09 17</a>	12	11	24	45	43	28	25	46	31	69	0.256
12	G1/2	<a href="#">0471 12 21</a>	15	12	27	47	44	32	29	49	34	69	0.303
18	G3/4	<a href="#">0471 18 27</a>	16.5	12	38	59	51	37	39	60	39	108	0.682
23	G1	<a href="#">0471 23 34</a>	19	15	46	63	55	44	48	72	47	108	1.020

Maximum working pressure: 20 bar

Ball Valves  
Industrial Valves

# Universal Series

## 0482 3/3 Right-Angle Ported Ball Valve, Female BSPP Thread



Nickel-plated brass, NBR

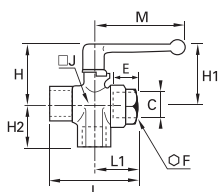

DN	C		E	F	H	H1	H2	J	L	L1	M	Kg
4	G1/8	0482 04 10	8	14	35	29	18	14	44	25	48	0.102
6	G1/4	0482 06 13	12	19	38	31	24	22	53	28	48	0.200
9	G3/8	0482 09 17	12	24	45	43	27	25	59	31	69	0.284
12	G1/2	0482 12 21	15	27	47	44	33	29	67	34	69	0.346
18	G3/4	0482 18 27	16.5	38	59	51	40	39	80	39	108	0.742
23	G1	0482 23 34	19	46	63	55	47	48	94	47	108	1.160

Maximum working pressure: 20 bar

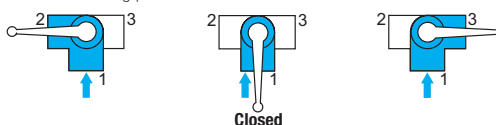

## 0483 3/3 Right-Angle Ported Ball Valve Without Closed Position, Female BSPP Thread



Nickel-plated brass, NBR

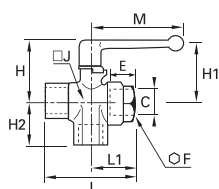

DN	C		E	F	H	H1	H2	J	L	L1	M	Kg
4	G1/8	0483 04 10	8	14	35	29	18	14	44	25	48	0.102
6	G1/4	0483 06 13	12	19	38	31	24	22	53	28	48	0.196
9	G3/8	0483 09 17	12	24	45	43	27	25	59	31	69	0.278
12	G1/2	0483 12 21	15	27	47	44	33	29	67	34	69	0.340
18	G3/4	0483 18 27	16.5	38	59	51	40	39	80	39	108	0.716
23	G1	0483 23 34	19	46	63	55	47	48	94	47	108	1.066

Maximum working pressure: 20 bar

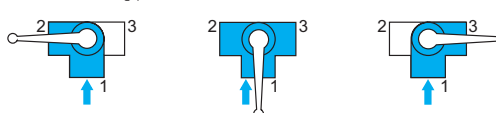

## 0448 3/3 Panel-Mountable Right-Angled Ball Valve, Female BSPP Thread



Nickel-plated brass, NBR

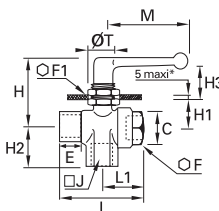

DN	C		E	F	F1	H	H1	H2	H3	J	L	L1	M	ØT	Kg
4	G1/8	0448 04 10*	8	14	22	37	14	18	12	14	44	25	48	16.5	0.126
6	G1/4	0448 06 13	12	19	24	45	19	24	14	22	53	28	48	20.5	0.230
9	G3/8	0448 09 17	12	24	27	50	21	27	21	25	59	31	69	20.5	0.328
12	G1/2	0448 12 21	15	27	27	51	23	33	21	29	67	34	69	20.5	0.392

Maximum working pressure: 20 bar

\*For G1/8 version: maximum panel thickness = 3 mm

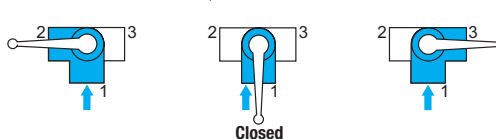

## 0452 3/2 Panel-Mountable Equal Plane Ball Valve, Female BSPP Thread



Nickel-plated brass, NBR

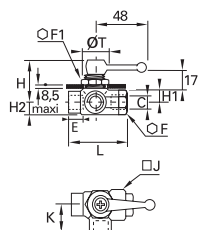

DN	C		E	F	F1	H	H1	H2	J	K	L	ØT	Kg
4	G1/8	0452 04 10	8	14	22	39	10	8	16	18	25	19	0.130
6	G1/4	0452 06 13	12	19	24	40	11	11	23	24	28	20	0.206

Maximum working pressure: 20 bar

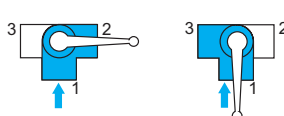

# Universal Series, Vented

## 0489 3/2 In-Line Vented Ball Valve, Female BSPP and Metric Thread



Nickel-plated brass, NBR

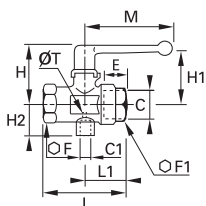

DN	C	C1		E	F	F1	H	H1	H2	L	L1	M	ØT	Kg
7	G1/4	M5x0.8	<a href="#">0489 07 13</a>	12	24	24	46	43	17	59	31	69	2	0.270
10	G3/8	M5x0.8	<a href="#">0489 10 17</a>	12	24	24	46	43	17	59	31	69	2	0.243
13	G1/2	G1/8	<a href="#">0489 13 21</a>	15	27	27	47	44	24	67	34	69	2	0.310
18	G3/4	G1/4	<a href="#">0489 18 27</a>	16.5	32	38	63	54	33	80	39	108	2.5	0.670
23	G1	G1/4	<a href="#">0489 23 34</a>	19	41	46	67	57	37	94	47	108	3	1.050

Maximum working pressure: 40 bar

## 0449 3/2 Panel-Mountable In-Line Ball Valve, Female BSPP and Metric Thread



Nickel-plated brass, NBR

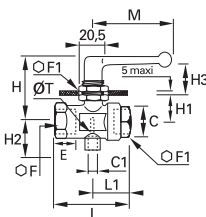

DN	C	C1		E	F	F1	H	H1	H2	H3	L	L1	M	ØT	Kg
7	G1/4	M5x0.8	<a href="#">0449 07 13</a>	12	24	27	50	20	17	21	59	31	69	2.5	0.313
10	G3/8	M5x0.8	<a href="#">0449 10 17</a>	12	24	27	50	20	17	21	59	31	69	2.5	0.291
13	G1/2	G1/8	<a href="#">0449 13 21</a>	15	27	27	52	23	24	21	67	34	69	4	0.352

Maximum working pressure: 20 bar

## 0469 3/2 In-Line Vented Ball Valve, Female BSPP Thread



Nickel-plated brass, NBR

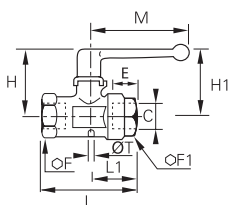

DN	C			E	F	F1	H	H1	L	L1	M	ØT	Kg
4	G1/8	<a href="#">0469 04 10</a>		8	14	14	35	29	44	25	48	1.5	0.092
7	G1/4	<a href="#">0469 07 13</a>		12	24	24	46	43	59	31	70	2	0.268
10	G3/8	<a href="#">0469 10 17</a>		12	24	24	46	43	59	31	70	2	0.246
13	G1/2	<a href="#">0469 13 21</a>		15	27	27	47	44	67	34	70	2	0.293
18	G3/4	<a href="#">0469 18 27</a>		16.5	32	38	63	54	80	39	108	2.5	0.668
23	G1	<a href="#">0469 23 34</a>		19	41	46	67	57	94	47	108	3	1.026

Maximum working pressure: 40 bar

### Operation of Vented Ball Valves

With vent connected to a tube = collection of purged media

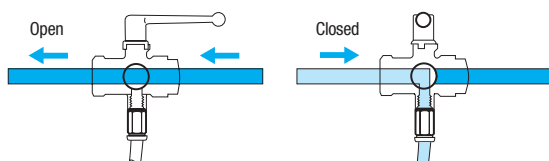

With vent connected to a silencer = noiseless discharge to atmosphere

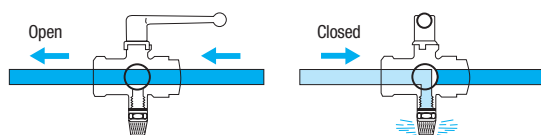

You will find our ranges of fittings, tubing and silencers in Chapters 1, 3 and 4.

# Universal Series, Vented

## 0462 3/2 Right-Angled Ball Valve with Vent, Female BSPP Thread

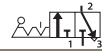

Nickel-plated brass, NBR

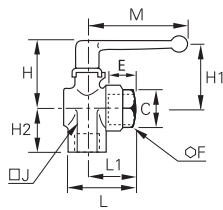

DN	C		E	F	H	H1	H2	J	L	L1	M	Kg
6	G1/8	0462 06 10	8	19	38	31	20	22	37	27	48	0.192
	G1/4	0462 06 13	12	19	38	31	24	22	38	28	48	0.185
9	G3/8	0462 09 17	12	24	45	43	27	25	46	31	69	0.261
12	G1/2	0462 12 21	15	27	47	44	33	29	49	34	69	0.311
18	G3/4	0462 18 27	16.5	38	59	51	40	39	60	39	108	0.698
23	G1	0462 23 34	19	46	63	55	47	48	72	47	108	1.066

Maximum working pressure: 20 bar

## 0461 3/2 Right-Angled Ball Valve with Vent, Male/Female BSPP Thread

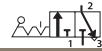

Nickel-plated brass, NBR

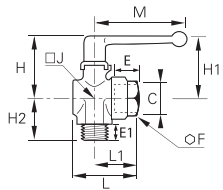

DN	C		E	E1	F	H	H1	H2	J	L	L1	M	Kg
6	G1/8	0461 06 10	8	7	19	38	31	20	22	37	27	48	0.182
	G1/4	0461 06 13	12	9	19	38	31	24	22	38	28	48	0.186
9	G3/8	0461 09 17	12	11	24	45	43	27	25	46	31	69	0.257
12	G1/2	0461 12 21	15	12	27	47	44	33	29	49	34	69	0.304
18	G3/4	0461 18 27	16.5	12	38	59	51	40	39	60	39	108	0.648

Maximum working pressure: 20 bar

### Operation of Right-Angled Vented Ball Valves

### Operation of Lockable Vented Ball Valves

With pin-hole vent = purge to atmosphere without silencer

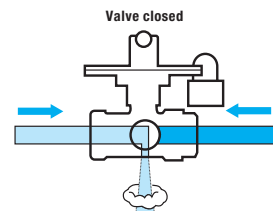
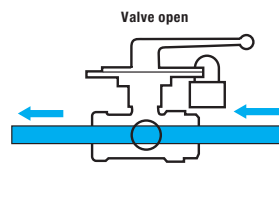
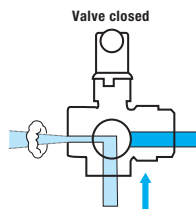
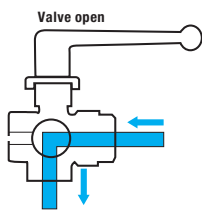

**Removable lever:** where the lever is obstructed in its movement, it can be refitted the opposite way.

### Operation of 3/2 Lockable Valves

Drilled below and square in the horizontal plane, these valves provide a connection between: either port 1 and port 2, or port 2 and port 3.

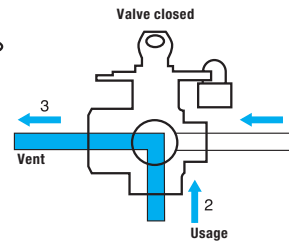
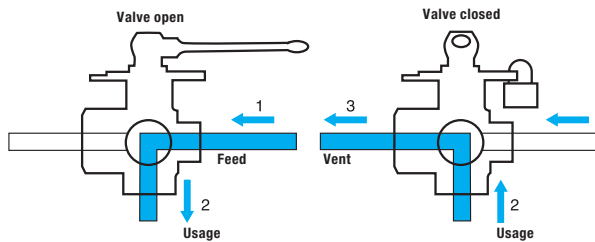

**Removable lever:** where the lever is obstructed in its movement, it can be refitted the opposite way.

# Universal Series, Lockable

## 0432 2/2 In-Line Lockable Ball Valve, Female BSPP Thread



Nickel-plated brass, NBR

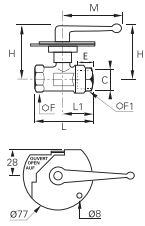

DN	C		E	F	F1	H	H1	L	L1	M	Kg
4	G1/8	<a href="#">0432 04 10</a>	8	19	19	59	54	51	27	69	0.415
7	G1/4	<a href="#">0432 07 13</a>	12	19	19	59	54	59	28	69	0.396
10	G3/8	<a href="#">0432 10 17</a>	12	24	24	60	55	59	31	69	0.460
13	G1/2	<a href="#">0432 13 21</a>	15	27	27	62	57	67	34	69	0.510
20	G3/4	<a href="#">0432 20 27</a>	16.5	32	38	66	56	80	39	108	0.800
23	G1	<a href="#">0432 23 34</a>	19	41	46	70	59	94	47	108	1.186

Maximum working pressure: 40 bar  
 Handle is not removable.  
 Fixed and mobile plates: zinc-plated steel.

## 0439 3/2 In-line Vented Lockable Ball Valve, Female BSPP Thread

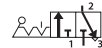

Nickel-plated brass, NBR

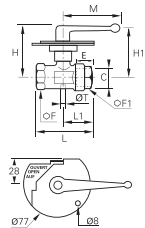

DN	C		E	F	F1	H	H1	L	L1	M	ØT	Kg
4	G1/8	<a href="#">0439 04 10</a>	8	19	19	59	54	51	27	69	2	0.410
7	G1/4	<a href="#">0439 07 13</a>	12	24	24	60	55	59	31	69	2	0.480
10	G3/8	<a href="#">0439 10 17</a>	12	24	24	60	55	59	31	69	2	0.460
13	G1/2	<a href="#">0439 13 21</a>	15	27	27	62	57	67	34	69	2	0.514
18	G3/4	<a href="#">0439 18 27</a>	16.5	32	38	66	56	80	39	108	2.5	0.810
23	G1	<a href="#">0439 23 34</a>	19	41	46	70	59	94	47	108	3	1.185

Maximum working pressure: 40 bar  
 Handle is not removable, locking plates are zinc-plated steel.

## 0436 3/2 In-Line Lockable Ball Valve with Threaded Exhaust Port, Female BSPP and Metric Thread



Nickel-plated brass, NBR

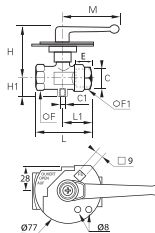

DN	C	C1		E	F	F1	H	H1	L	L1	M	Kg
10	G3/8	M5x0.8	<a href="#">0436 10 17</a>	12	24	24	60	17	60	32	69	0.475
13	G1/2	G1/8	<a href="#">0436 13 21</a>	15	27	27	60	24.5	67.5	34.5	69	0.500
18	G3/4	G1/4	<a href="#">0436 18 27</a>	16.5	32	38	69.5	33	80	39.5	108	0.850
23	G1	G1/4	<a href="#">0436 23 34</a>	19	32	38	69.5	33	80	39.5	108	1.215

Maximum working pressure: 40 bar  
 Handle is not removable.  
 Fixed and mobile plates: zinc-plated steel

## 0437 3/2 In-line Vented 3-Point Lockable Ball Valve, Female BSPP Thread

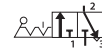

Nickel-plated brass, NBR

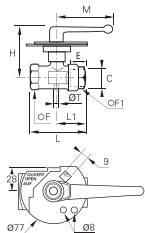

DN	C		E	F	F1	H	L	L1	M	ØT	Kg
7	G1/4	<a href="#">0437 07 13</a>	12	24	24	60	59	32	69.5	2	0.476
10	G3/8	<a href="#">0437 10 17</a>	12	24	24	60	60	32	69.5	2	0.447
13	G1/2	<a href="#">0437 13 21</a>	15	27	27	60	67.5	34.5	69.5	2	0.510
18	G3/4	<a href="#">0437 18 27</a>	16.5	32	38	69.5	80	39.5	108.5	2.5	0.820
23	G1	<a href="#">0437 23 34</a>	19	41	46	73	94.5	47.5	108.5	3	1.192

Maximum working pressure: 40 bar  
 Handle is not removable  
 Locking plates are zinc-plated steel

## 0438 3/2 Right-Angled 3-Point Lockable Ball Valve, Female BSPP Thread

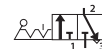

Nickel-plated brass, NBR

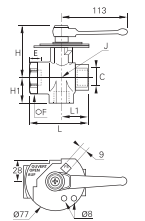

DN	C		E	F	H	H1	J	L	L1	Kg
9	G3/8	<a href="#">0438 09 17</a>	12	38	76	34	39	73	35	0.970
12	G1/2	<a href="#">0438 12 21</a>	15	38	76	37	39	78	38	0.947
18	G3/4	<a href="#">0438 18 27</a>	16.5	38	76	40	39	80	40	0.905
23	G1	<a href="#">0438 23 34</a>	19	46	80	47	48	94	47	1.295

Maximum working pressure: 20 bar  
 Fixed plate: zinc-plated steel, mobile plate: steel, grey epoxy-coated  
 Removable handle: where the handle is obstructed in its movement, it can be refitted opposite the original position.

# Ball Valves, Universal Light Series

Using the Universal Series technology, the Parker Legris light series valves offer the advantages of **compactness**, **ease of operation** and **long-term reliability**.

## Product Advantages

- Easy-to-Use** | Ease of operation due to the low friction design  
 The short levers may be repositioned and exchanged  
 Extremely compact  
 Wide range of configurations
- Maximum Efficiency** | Excellent performance under vacuum  
 Full flow  
 Chemical nickel-plated brass with high phosphorous content for outstanding corrosion resistance  
 Automatic seal wear compensation system
- Reliability** | Tried-and-tested technology  
 Forged brass provides mechanical strength and long service life  
 100% leak-tested in production  
 Date coding to guarantee quality and traceability



**Applications**

- Vacuum
- Transportation
- Packaging
- Textile
- Pneumatics
- Sawmills
- Rubber & Plastics

## Technical Characteristics

<b>Compatible Fluids</b>	Compressed air Other fluids: see compatibility chart at the end of this chapter
<b>Working Pressure</b>	Vacuum to 12 bar
<b>Working Temperature</b>	-20°C to +80°C

<b>Tightening Torques</b>	Threads	G1/8	G1/4	G3/8	G1/2	G3/4
	daN.m	0.10 to 0.20	0.10 to 0.20	0.15 to 0.25	0.20 to 0.35	0.50 to 0.70

Reliable performance is dependent upon the type of fluid conveyed, component materials and tubing being used.  
Guaranteed for use with a vacuum of 755 mm Hg (99% vacuum).

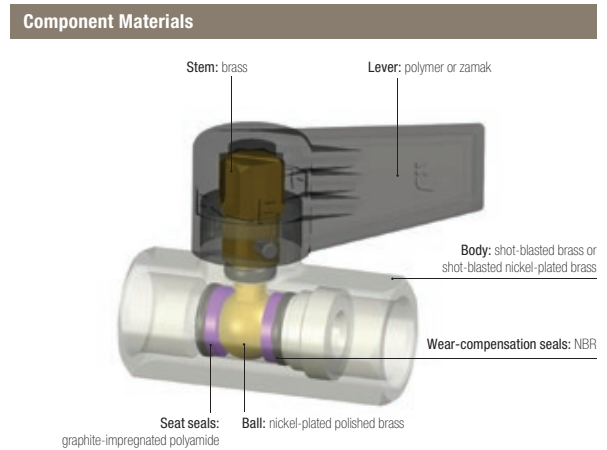

**Silicone-free**

**Regulations**

- DI: 97/23/EC (module PED A - diameters greater than 25 mm)
- DI: 2006/42/EC (Machinery Directive)
- DI: 2002/95/EC (RoHS)
- RG: 1907/2006 (REACH)

# Universal Light Series

## 0492 2/2 In-Line Ball Valve, Female BSPP Thread



Nickel-plated brass, NBR

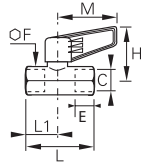

DN	C		E	F	H	L	L1	M	Kg
4	G1/4	<a href="#">0492 04 13</a>	9	17	34	39.5	17	35	0.073
7	G3/8	<a href="#">0492 07 17</a>	11	22	38	45	20	43	0.128
10	G1/2	<a href="#">0492 10 21</a>	12	24	44	54	25	50	0.162
13	G3/4	<a href="#">0492 13 27</a>	14	30	46	62	28	50	0.240

Technical polymer handle

## 0492..64 2/2 In-Line Ball Valve, Short Handle, Female BSPP Thread



Nickel-plated brass, NBR

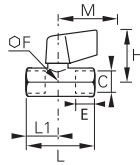

DN	C		E	F	H	L	L1	M	Kg
4	G1/4	<a href="#">0492 04 13 64</a>	9	17	36	39.5	17	25	0.090

\*Short handle in zamac

## 0491 2/2 In-Line Ball Valve, Male/Female BSPP Thread



Nickel-plated brass, NBR

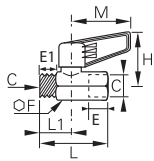

DN	C		E	E1	F	H	L	L1	M	Kg
4	G1/4	<a href="#">0491 04 13</a>	9	7	17	34	39.5	17	35	0.070
7	G3/8	<a href="#">0491 07 17</a>	11	8	22	38	45	20	43	0.124
10	G1/2	<a href="#">0491 10 21</a>	12	10	24	44	53	24	50	0.160
13	G3/4	<a href="#">0491 13 27</a>	14	12	30	46	59	25	50	0.238

Technical polymer handle

## 0491..64 2/2 In-Line Ball Valve, Short Handle, Male/Female BSPP Thread



Nickel-plated brass, NBR

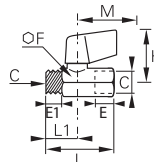

DN	C		E	E1	F	H	L	L1	M	Kg
4	G1/4	<a href="#">0491 04 13 64</a>	9	7	17	36	39.5	17	25	0.092

\*Short handle in zamac

## 0490 2/2 In-Line Ball Valve, Male BSPP Thread



Nickel-plated brass, NBR

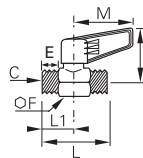

DN	C		E	F	H	L	L1	M	Kg
4	G1/4	<a href="#">0490 04 13</a>	7	17	34	39	17	35	0.070
7	G3/8	<a href="#">0490 07 17</a>	8	22	38	44	20	43	0.109
10	G1/2	<a href="#">0490 10 21</a>	10	24	44	53	24	50	0.160
13	G3/4	<a href="#">0490 13 27</a>	12	30	46	59	25	50	0.233

Technical polymer handle

Ball Valves  
Industrial Valves

# Universal Light Series

## 0494 2/2 In-Line Ball Valve, 2 Vent Plugs, Female BSPP Thread



Nickel-plated brass, NBR

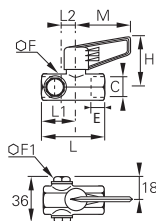

DN	C		E	F	F1	H	L	L1	L2	M	Kg
7	G3/8	<a href="#">0494 07 17</a>	11	22	16	38	60	20	15	43	0.178

Technical polymer handle

## 0497 2/2 Ball Valve, Square Stem, Female BSPP Thread



Brass, NBR

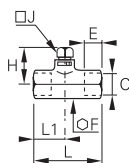

DN	C		E	F	H	J	L	L1	Kg
4	G1/4	<a href="#">0497 04 13</a>	9	17	25	7	39	17	0.063
7	G3/8	<a href="#">0497 07 17</a>	11	22	26	7	45	20	0.122
10	G1/2	<a href="#">0497 10 21</a>	12	24	29	10	54	25	0.141
13	G3/4	<a href="#">0497 13 27</a>	14	30	30	10	62	28	0.230

## 0496 2/2 Ball Valve, Square Stem, Male/Female BSPP Thread



Brass, NBR

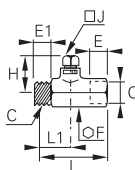

DN	C		E	E1	F	H	J	L	L1	Kg
4	G1/4	<a href="#">0496 04 13</a>	7	9	17	25	7	39	17	0.065
7	G3/8	<a href="#">0496 07 17</a>	8	11	22	26	7	45	20	0.118
10	G1/2	<a href="#">0496 10 21</a>	10	12	24	29	10	53	24	0.150
13	G3/4	<a href="#">0496 13 27</a>	12	14	30	30	10	59	28	0.222



HANLEY CONTROLS

CLONMEL

[www.hccl.ie](http://www.hccl.ie)



Ball Valves

Industrial Valves

# Ball Valves, DVGW Series

The combination of long threads, a reinforced sealing system and **DVGW** certification makes this valve perfect for the **transmission of gas and water**.

## Product Advantages

- Reliability & Sealing**
  - Stem prevented from being ejected in the event of overpressure
  - Two stem seals to prevent leakage
  - Date coding to guarantee quality and traceability
- Optimum Performance**
  - Full flow minimises pressure drop
  - Nickel-plated brass provides improved corrosion resistance and increased chemical compatibility
  - Can be operated at very low temperatures (-50°C)
- Long Threads**
  - Excellent fitting compatibility:
    - dimensions compliant with DIN 3357
    - BSPP threads compliant with DIN 2999/ISO 228



**Applications**

Robotics  
Pneumatics  
Water & Gas Handling  
Machine Tools  
Textile  
Wood Industry

## Technical Characteristics

<b>Compatible Fluids</b>	Compressed air, water, gas
<b>Working Pressure</b>	1/4" to 2": 0 to 40 bar
<b>Working Temperature</b>	-50°C to +170°C

Reliable performance is dependent upon the type of fluid conveyed. Products have been tested at -50°C in static sealing and after 5 operations for a leak rate < 0,05NI/h.

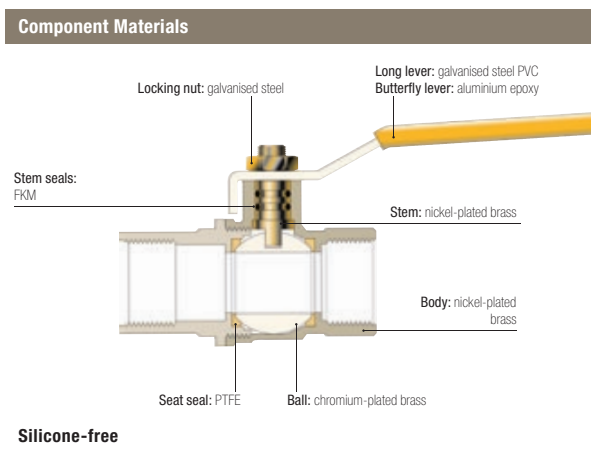

### Working Pressure and Temperature

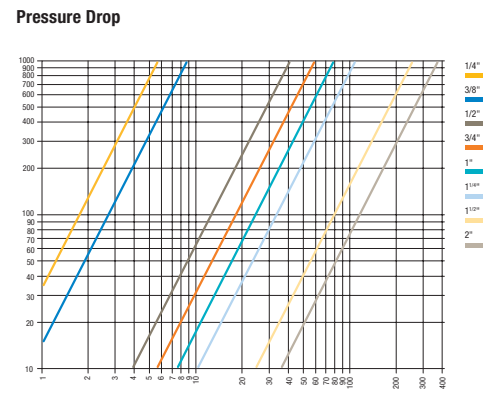
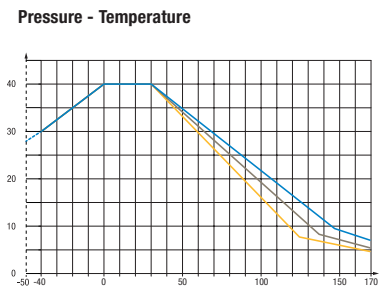

### Regulations

**Industrial**  
 DI: 97/23/EC  
 (PED B+D module EC 1115)

**Water**  
 DVGW: W 570-1  
 DIN EN 13228  
 BGA KTW  
 DVGW: W270

**Gas**  
 DIN EN 33

# DVGW Series

## BVG4-L 2/2 In-Line Ball Valve, Female BSPP Thread



Nickel-plated brass

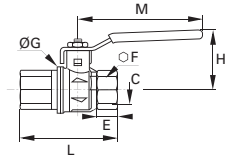

DN	C		E	F	G	H	L	M	Kg
8	G1/4	<a href="#">BVG4-1/4L</a>	12	20	25	38	50	82	0.150
10	G3/8	<a href="#">BVG4-3/8L</a>	12	20	25	38	60	82	0.150
15	G1/2	<a href="#">BVG4-1/2L</a>	15.5	25	32.5	43	75	100	0.255
20	G3/4	<a href="#">BVG4-3/4L</a>	17	32	39	50	80	120	0.390
25	G1	<a href="#">BVG4-1L</a>	21	41	47.5	54	90	120	0.590
32	G1 1/4	<a href="#">BVG4-1.1/4L</a>	23	50	59	73	110	158	0.980
40	G1 1/2	<a href="#">BVG4-1.1/2L</a>	23	55	71.5	79	120	158	1.205
50	G2	<a href="#">BVG4-2L</a>	26.5	70	86	86	140	158	1.960

## BVGT4-L 2/2 In-Line Ball Valve, Female BSPP Thread

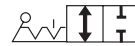

Nickel-plated brass

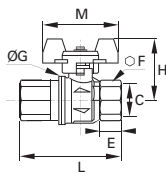

DN	C		E	F	G	H	L	M	Kg
8	G1/4	<a href="#">BVGT4-1/4L</a>	12	20	25	39	50	50	0.150
10	G3/8	<a href="#">BVGT4-3/8L</a>	12	20	25	39	60	50	0.150
15	G1/2	<a href="#">BVGT4-1/2L</a>	15.5	25	32.5	43	75	50	0.230
20	G3/4	<a href="#">BVGT4-3/4L</a>	17	32	39	47	80	60	0.350
25	G1	<a href="#">BVGT4-1L</a>	21	41	47.5	51	90	60	0.550

Compact lever

# Ball Valves, Standard Series

This range of valves with **fluoropolymer seals**, available in compact, standard and lockable series, covers many **industrial applications** for which the fluids conveyed and working temperatures require this seal material.

## Product Advantages

**Optimised Installation**

- Full fluid flow
- Long or butterfly lever
- Corrosion resistance
- A lockable version for operational safety
- Good value/performance ratio

**Wide Compatibility**

- Numerous compatible fluids
- Can be used for low and medium pressure applications
- Surface treatment for corrosion protection



**Applications**

- Machine Tool
- Agricultural Machinery
- Textile
- Pneumatics
- Plumbing
- Air Conditioning
- Heating

## Technical Characteristics

Model	Standard and Lockable Series	Compact Series
<b>Compatible Fluids</b>	Compressed air, gas, water, water vapour, oil and all fluids compatible with the component materials	
<b>Working Pressure</b>	0 to 30 bar	0 to 35 bar
<b>Working Temperature</b>	-20°C to +130°C	-10°C to +90°C

Reliable performance is dependent upon the type of fluid conveyed.

### Component Materials

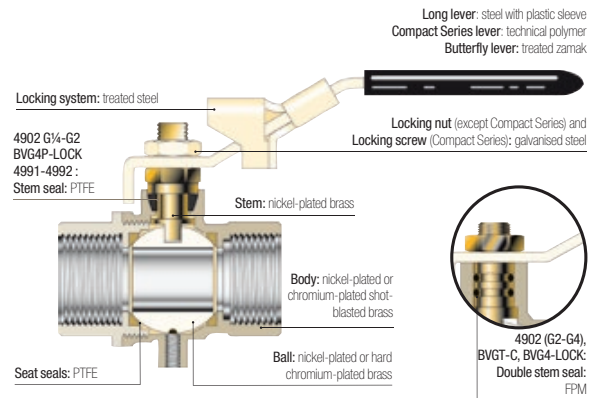

### Silicone-free

### Regulations

**Industrial**  
 DI: 97/23/EC (module PED A - EC diameters greater than 25 mm)  
 DI: Machinery Directive 2006/42/EC  
 DI: 2002/95/EC (RoHS)  
 RG: 1907/2006 (REACH)  
 DI: 89/392/EC

# Standard Series

## 4902

### 2/2 Standard In-Line Ball Valve, Female BSPP Thread



Nickel-plated brass, PTFE

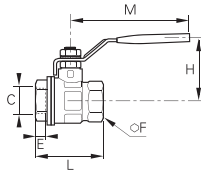

DN	C		E	F	H	L	M	Kg
10	G1/4	<a href="#">4902 10 13</a>	11	20	43	51.5	98	0.154
	G3/8	<a href="#">4902 10 17</a>	11	20	43	51.5	98	0.138
15	G1/2	<a href="#">4902 15 21</a>	13.5	25	47	55	98	0.204
20	G3/4	<a href="#">4902 20 27</a>	12.5	31	58	57.5	122	0.322
25	G1	<a href="#">4902 25 34</a>	15	38	60	69.5	122	0.468
32	G1 1/4	<a href="#">4902 32 42*</a>	17	48	77	81.5	153	0.794
40	G1 1/2	<a href="#">4902 40 49*</a>	18	54	83	95	153	1.082
50	G2	<a href="#">4902 50 48*</a>	22	66	95	113	162	1.787
65	G2 1/2	<a href="#">4902 65 47*</a>	22	85	132	136	255	4.500
80	G3	<a href="#">4902 80 46*</a>	25	99	140	157	255	5.840
100	G4	<a href="#">4902 01 45*</a>	29	125	154	191	255	9.040

\*Models with EC marking

Model from 2 1/2": double stem seal in FPM

Working temperature: -40°C to +170°C (en pointe)

## 4991

### 2/2 Standard Compact In-Line Ball Valve, Male/Female BSPP Thread



Chromium-plated brass, PTFE

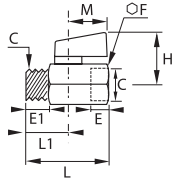

DN	C		E	E1	F	H	L	L1	M	Kg
6	G1/8	<a href="#">4991 00 10</a>	10	10	21	30	41.5	10	24	0.089
	G1/4	<a href="#">4991 00 13</a>	11	11	21	30	41.5	11	24	0.082
8	G3/8	<a href="#">4991 00 17</a>	11	11	21	30	41.5	10.5	24	0.087
	G1/2	<a href="#">4991 00 21</a>	13	13	25	32	49	12.5	24	0.134

## 4992

### 2/2 Standard Compact In-Line Ball Valve, Female BSPP Thread



Chromium-plated brass, PTFE

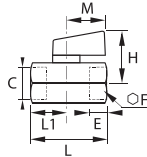

DN	C		E	F	H	L	L1	M	Kg
6	G1/8	<a href="#">4992 00 10</a>	10	21	30	41.5	10	24	0.110
	G1/4	<a href="#">4992 00 13</a>	11	21	30	41.5	11	24	0.106
8	G3/8	<a href="#">4992 00 17</a>	11	21	30	41.5	10.5	24	0.094
	G1/2	<a href="#">4992 00 21</a>	13	25	32	49	12.5	24	0.142

## BVGT4-C

### 2/2 Standard In-Line Ball Valve, Female BSPP Thread



Nickel-plated brass

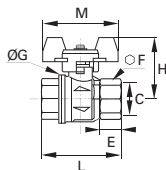

DN	C		E	F	G	H	L	M	Kg
8	G1/4	<a href="#">BVGT4-1/4C</a>	9	20	25	40	39	50	0.130
10	G3/8	<a href="#">BVGT4-3/8C</a>	9	20	25	40	39	50	0.120
15	G1/2	<a href="#">BVGT4-1/2C</a>	11	25	32.5	44	50	50	0.180
20	G3/4	<a href="#">BVGT4-3/4C</a>	12	31	39	49	54	50	0.265
25	G1	<a href="#">BVGT4-1C</a>	14	38	47.5	53	67	50	0.390

Compact lever

# Standard Series

## BVG4-LOCK

2/2 In-Line Lockable Ball Valve, Female BSPP Thread



Nickel-plated brass

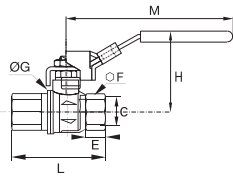

DN	C		E	F	ØG	H	L	M	Kg
8	G1/4	<a href="#">BVG4-1/4LOCK</a>	12	20	25	38	50	82	0.150
10	G3/8	<a href="#">BVG4-3/8LOCK</a>	12	20	25	38	60	82	0.150
15	G1/2	<a href="#">BVG4-1/2LOCK</a>	15.5	25	32.5	43	75	100	0.255
20	G3/4	<a href="#">BVG4-3/4LOCK</a>	17	32	39	50	80	120	0.390
25	G1	<a href="#">BVG4-1LOCK</a>	21	41	47.5	54	90	120	0.590

Double stem seal in FPM  
Working temperature: -40°C to +170°C

## BVG4P-LOCK

3/2 In-Line Lockable Vented Ball Valve, Female BSPP Thread

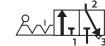

Nickel-plated brass

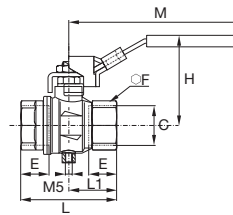

DN	C		E	F	H	L	L1	M	Kg
8	G1/4	<a href="#">BVG4P-1/4LOCK</a>	12	20	47.5	45	22.5	96	0.155
10	G3/8	<a href="#">BVG4P-3/8LOCK</a>	12	20	47.5	45	22.5	96	0.172
15	G1/2	<a href="#">BVG4P-1/2LOCK</a>	15.5	25	52	59	29.5	96	0.239
20	G3/4	<a href="#">BVG4P-3/4LOCK</a>	17	31	59.5	64	32	117	0.371
25	G1	<a href="#">BVG4P-1LOCK</a>	21	40	63.5	81	40.5	117	0.581

Working pressure: 14 bar  
Working temperature: -10°C to +100°C

# Ball Valves: Usage Chart

The chart below shows the compatibility between valves and fluids along with their pressure and temperature characteristics.

Certain models have a maximum working pressure which differs from that given in this table. In this case, the pressure is shown in the heading for the model number in question.

N.B.: Above 32 mm or 1¼" diameters, divide the maximum pressure by 2.

If the fluid you are using is not shown in this chart, please contact us.

Chemical Description	Maximum Pressure (bar)	Temperature °C		Universal and Light Series	Standard Series	DVGW series	Customised Series							
		Min.	Max.				20	22	26	27	30	32		
"Aromatic" hydrocarbons	20	-20	+60					●						
Acetone and other ketones	20	-20	+60											●
Acetophenone	20	-20	+60											●
Acetylene - Acetone	20	-20	+60											●
Acetylene (gas)	20	-20	+60	●	●	●								
Alcohol (100%)	20	-20	Boiling											●
Aluminium (liquid suspension, thick)	40	-20	+90	●	●	●								
Amyl alcohol	20	-20	Boiling											●
Animal fats, greases	20	+5	+200		●	●			●					
Antifreeze or glycol (diluted)	40	-20	+40	●	●	●								
Argon (gas) Ar	20	-20	+60	●	●	●								
Barium - Hydroxide	20	-20	+40											●
Benzaldehyde	20	-20	+60											●
Benzene	20	-20	+60					●						
Benzyl alcohol	20	-20	Boiling					●						
Borax (pastes or solutions)	20	-20	+60											●
Brake fluids (automobile)	20	-20	+90											●
Bromochlorotrifluoroethane	20	-20	+60		●	●			●					
Butadiene (hydrocarbon)	20	-20	+60								●			
Butane	20	-20	+60	●	●	●								
Butanol	20	-20	Boiling					●						
Butyl alcohol	20	-20	Boiling					●						
Butylene (hydrocarbon)	20	-20	+60					●						
Carbon dioxide gas CO <sub>2</sub>	40	-20	+60	●	●									
Castor oil	40	-20	+90	●	●									
Compressed air	20	-25	+180	●	●	●	●	●	●	●	●	●	●	●
Creosotes	20	-20	+60								●			
Cresols	20	-20	+60								●			
Crude oil	20	-20	+40				●							
Cutting oil	40	-20	+90	●	●									
Decalin (hydrocarbon, solvent)	20	-20	+60								●			
Detergents (solutions)	20	-20	+100											●
Diacetone alcohol	20	-20	Boiling											●
Diesel oils	40	-20	+90	●	●									
Di-Esters	20	-20	+90					●						
Di-Isobutylene	20	-20	+60								●			
Di-Pentane	20	-20	+60					●						

Ball Valves  
Industrial Valves

The above recommendations are given in good faith. However, since each application is different, it is advisable to undertake tests in actual working conditions.

# Ball Valves: Usage Chart

Chemical Description	Max. Pressure (bar)	Temperature °C		Universal and Light Series	Standard Series	DVGW Series	Customised Series						
		Min.	Max.				20	22	26	27	30	32	
Di-Pentene (solvents, varnish)	20	-20	+60					●					
Di-Phenyl-Oxide (thin detergents)	20	-20	+60								●		
Distilled water	40		+90	●	●	●							
Edible fats	20	+5	+200		●					●			
Edible oils	20	+5	+200		●					●			
Erytrene (see Butadiene)	20	-20	+60								●		
Ethane (gas) CH <sub>2</sub> CH <sub>3</sub>	20	-20	+60	●	●								
Ethane (hydrocarbon gas)	20	-20	+60								●		
Ethyl alcohol	20	-20	+60										●
Ethylene glycol (antifreeze) - see Glycols	20	-20	+120										●
Fatty alcohols	20	-20	Boiling					●					
Fuel oils	40	-20	+40	●	●	●							
Fuels-Diesels	40	-20	+40	●	●								
Gaseous oxygen (ambient air)	20	-20	+40									●	
Glycerine	20	-20	+40	●	●								
Glycol (for antifreeze, lubricants)	40	-20	+40	●	●								
Graphite in suspension in water, oils and greases	40	-20	+90	●	●								
Greases (from petroleum)	40	-20	+90	●	●								
Helium (gas)	20	-20	+60									●	
Heptanal	20	-20	+50	●	●								
Hexane (solvent)	20	-20	+60									●	
Hydraulic oils (petroleum-based)	40	-20	+90	●	●								
Hydrogen (gas)	20	-20	+60									●	
Inks	20	-20	+60								●		
Insecticides	20	0	+40	●	●	●							
Iso-Butane (aliphatic hydrocarbon)	20	-20	+60								●		
Iso-Octane	20	-20	+60								●		
Isopropyl alcohol	20	-20	Boiling										●
Krypton (gas) Kr	20	-20	+60	●	●	●							
Light water	40		+80	●	●	●							
Lighting gas	20	-20	+40			●							
Methane (gas) CH <sub>4</sub>	20	-20	+60	●	●	●							
Methanol	20	-20	Boiling										●
Methyl alcohol	20	-20	Boiling										●
Methylated spirit	40	-20	+40	●	●	●							
Mineral oils	40	-20	+90	●	●								
Natural gas	20	-20	+40			●							
Natural waxes (vegetable, beeswax, carnauba, Chinese, lignite)	40	-20	+90								●		
Neatsfoot oil	40	-20	+90	●	●	●							
Neon (Gas) Ne	20	-20	+60	●	●	●							
Nitrogen (gas) N <sup>2</sup>	40	-20	+90	●	●	●							
Oil (petroleum-based) and water emulsions	40	-20	+90	●	●	●							

The above recommendations are given in good faith. However, since each application is different, it is advisable to undertake tests in actual working conditions.

# Ball Valves: Usage Chart

Chemical Description	Max. Pressure (bar)	Temperature °C		Universal and Light Series	Standard Series	DVGW Series	Customised Series						
		Min.	Max.				20	22	26	27	30	32	
Oils "synthetic"	20	-20	+100										●
Ordinary petrol	20	-20	+40	●	●								
Oxygenated water	40	-20	+30				●						
Paints and relevant solvents	20	-20	+60		●	●			●				
Paraffin oil	40	-20	+90	●	●	●							
Paraffins	20	-20	+60	●	●	●							
Pentane (liquid hydrocarbon)	20	-20	+60	●	●	●							
Pentanol 1 and 2	20	-20	Boiling										●
Petrol "super"	20	-20	+40				●						
Petroleum mineral oils	20	-20	+160					●					
Phenol (aqueous or alcoholic)	20	-20	+60		●	●			●				
Propane	20	-20	+60	●	●	●							
Propanol 1 and 2	20	-20	Boiling										●
Propanone 2	20	-20	+60										●
Propene or Propylene	20	-20	+60					●					
Propyl alcohol	20	-20	Boiling										●
Propylene or Propene	20	-20	+60					●					
Rapeseed oil	40	-20	+90	●	●								
Saponifying liquids	20	-20	+30	●	●	●							
Seawater	40		+80	●	●	●							
Seawater (high temperature)	20		+150			●				●			
Soaps	20	-20	+100										●
Soaps (liquid or paste)	40	-20	+40	●	●	●							
Sodium carbonate (with water)	20	0	+40	●	●	●							
Starch (gels or pastes)	40	+10	+40	●	●	●							
Steam	20	-20	+150										●
Toluene (terpenic hydrocarbon)	20	-20	+60		●	●			●				
Trichlorethylene	20	-20	+65					●					
Turpentine	20	-20	+50	●	●	●							
Varnish and paints	20	-20	+60		●	●			●				
Vaseline	40	-20	+60	●	●	●							
Vaseline oil	40	-20	+90	●	●	●							
Water (carbonated)	40		+90	●	●	●							
Water (high temperature)	20		+150			●							●
Xenon (gas) Xe	20	-20	+60	●	●	●							
Xylene	20	-20	+60					●					

Ball Valves  
Industrial Valves

The above recommendations are given in good faith. However, since each application is different, it is advisable to undertake tests in actual working conditions.

# Ball Valves, Stainless Steel Series

**Stainless steel** series ball valves can withstand **corrosive fluids** and **environments**.

With full flow, high pressure and temperature capabilities, these valves are suitable for many applications.

## Product Advantages

**Reliability** | Full flow  
 Excellent chemical compatibility  
 High resistance to pressure/temperature  
 Light series version: 100% leak-tested in production, date coding to guarantee quality and traceability

**Versatility** | Three in-line versions:

- One-piece: cannot be disassembled
- 3-piece: easily disassembled for maintenance and cleaning
- Light Series: for maximum compactness

Fixing plate: 4812 and 4832

- Through-bulkhead fitting
- Pneumatic or electronic actuation (ISO 5211 standard)



**Applications**

Food Process  
 Aviation  
 Chemical  
 Semi-Conductors  
 Medical  
 Petrochemical  
 Laboratories  
 Pharmaceutical

## Technical Characteristics

<b>Compatible Fluids</b>	Type 4810, 4812 and 4832	Type 0465
	All fluids	All fluids
<b>Working Pressure</b>	0 to 65 bar	Vacuum to 20 bar
<b>Working Temperature</b>	-20°C to +150°C	-20°C to +120°C

**Component Materials**

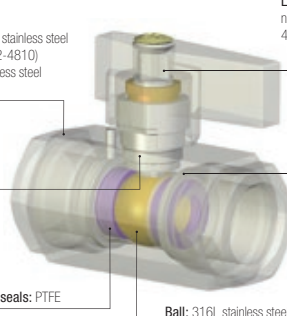

**Body:** 316L stainless steel (4832-4812-4810) or 303 stainless steel (0465)

**Lever:** nickel-plated brass (0465) or 430 stainless steel (4832-4812-4810)

**Stem:** 316L stainless steel (4832-4812-4810) or 303 stainless steel (0465)

**Stem seal:** PTFE

**Seat seals:** PTFE

**Wear-compensation seal:** 2 PTFE seals (0465) or 1 FKM seal (4832-4812-4810)

**Ball:** 316L stainless steel (4832-4812-4810) or 303 stainless steel (0465)

Reliable performance is dependent upon the type of fluid conveyed, component materials and tubing being used. Guaranteed for use with a vacuum of 755 mm Hg (99% vacuum).

### Pressure and Temperature Resistance

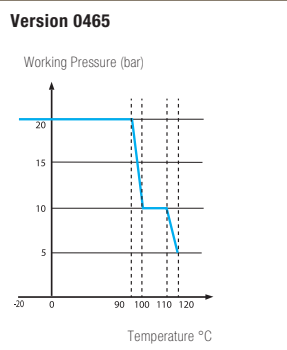
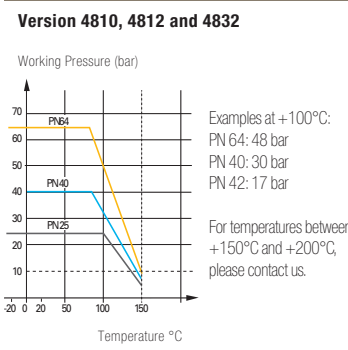

### Regulations

**Industrial**  
**DI:** 97/23/EC (module PED A - EC diameters greater than 25 mm)  
**DI:** Machinery Directive 2006/42/EC  
**DI:** 2002/95/EC (RoHS)  
**RG:** 1907/2006 (REACH)  
**DI:** 89/392/EC

# Stainless Steel Series

## 4832 2/2 In-Line 3-Piece Ball Valve with Fixing Plate, Female BSPP Thread



Stainless steel 316L, PTFE

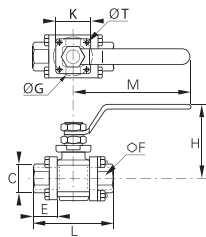

DN	C		E	F	G	H	K	L	M	ØT	Kg
10	G1/4	<a href="#">4832 10 13</a>	18	22	36	50	36	57	110.5	5.5	0.272
	G3/8	<a href="#">4832 10 17</a>	18	22	36	50	36	57	110.5	5.5	0.400
15	G1/2	<a href="#">4832 15 21</a>	20.5	27	36	64	36	65	131.5	6	0.442
20	G3/4	<a href="#">4832 20 27</a>	22.5	32	42	68	42	76	131.5	5.5	0.568
25	G1	<a href="#">4832 25 34</a>	27	41	42	78.5	42	92	174.5	6	1.035
32	G1 1/4	<a href="#">4832 32 42*</a>	30	50	42	83.5	42	106.5	174.5	5.5	1.530
40	G1 1/2	<a href="#">4832 40 49*</a>	31	55	50	100	50	116	250.5	6.5	2.146
50	G2	<a href="#">4832 50 48*</a>	36	70	50	107	50	136	250.5	6.5	3.140

\*Models with EC marking

## 4812 2/2 In-Line Ball Valve with Fixing Plate, Female BSPP Thread



Stainless steel 316L, PTFE

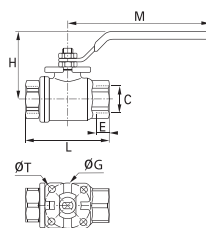

DN	C		E	G	H	L	M	ØT	Kg
10	G1/4	<a href="#">4812 10 13</a>	10	36	50	55	110	5.5	0.263
	G3/8	<a href="#">4812 10 17</a>	11	36	50	55	110	5.5	0.254
15	G1/2	<a href="#">4812 15 21</a>	15	36	53	66	110	5.5	0.336
20	G3/4	<a href="#">4812 20 27</a>	16	42	67	79	130	5.5	0.574
25	G1	<a href="#">4812 25 34</a>	19	42	79	93	175	5.5	1.000
32	G1 1/4	<a href="#">4812 32 42*</a>	21	42	83	100	175	5.5	1.337
40	G1 1/2	<a href="#">4812 40 49*</a>	21	50	100	110	250	5.5	2.214
50	G2	<a href="#">4812 50 48*</a>	26	70	107	131	250	8.5	3.262

\*Models with EC marking

## 4810 2/2 In-Line Ball Valve, Female BSPP Thread



Stainless steel 316L, PTFE

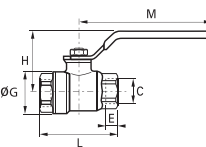

DN	C		E	G	H	L	M	Kg
8	G1/4	<a href="#">4810 08 13</a>	10	30	44.5	53.5	110.5	0.205
10	G3/8	<a href="#">4810 10 17</a>	10	30	44.5	53.5	110.5	0.194
15	G1/2	<a href="#">4810 15 21</a>	13	32.5	47	60	110.5	0.245
20	G3/4	<a href="#">4810 20 27</a>	14	40	54.5	70	131.5	0.420
25	G1	<a href="#">4810 25 34</a>	17	49	58.5	79	131.5	0.648

Threads conform to ISO 228-1

## 0465 2/2 In-Line Light Series Ball Valve, Female BSPP Thread



Stainless steel 303, PTFE

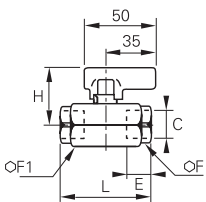

DN	C		E	F	F1	H	L	Kg
4	G1/4	<a href="#">0465 04 13</a>	13	19	24	36	50	0.226
7	G3/8	<a href="#">0465 07 17</a>	13	24	27	39	55	0.278
10	G1/2	<a href="#">0465 10 21</a>	16	27	30	40	62	0.322

Silicone-free

# Ball Valves, High Pressure Series

These valves are suitable for **applications** with pressures **up to 300 bar**. High performance materials and quality manufacturing allow for a wide range of operating pressures and temperatures.

## Product Advantages

### High Pressure & Safety

- Good sealing at low and high pressure
- Robust design with secure, non-removable inlet and outlet ports
- Forged brass providing excellent long-term strength under severe conditions of use
- 100% leak-tested in production
- Date coding to guarantee quality and traceability

### Easy-to-Use

- Fixing screws for through-bulkhead mounting
- The lever may be repositioned or replaced with a handwheel
- Low operating torque



- Applications**
- Automotive Process
  - Foundry
  - Forming
  - Machine Tools
  - Textile
  - Spectacle-Making Industry
  - Turbines
  - Deep-Sea Diving

## Technical Characteristics

<b>Compatible Fluids</b>	Compressed air
<b>Working Pressure</b>	Vacuum to 300 bar
<b>Working Temperature</b>	-15°C to +80°C

Reliable performance is dependent upon the type of fluid conveyed, component materials and tubing being used. Guaranteed for use with a vacuum of 755 mm Hg (99% vacuum).

### Component Materials

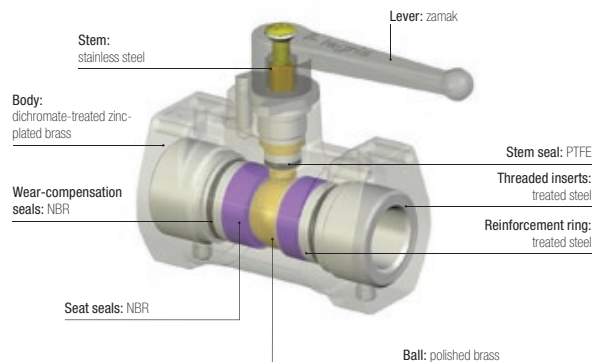

### Silicone-free

### Regulations

- DI: 97/23/EC (module PED A - diameters greater than 25 mm)
- DI: 2006/42/EC (Machinery Directive)
- DI: 2002/95/EC (RoHS)
- RG: 1907/2006 (REACH)

## Installation Options

### Bulkhead Mounting

Through bulkhead with screws

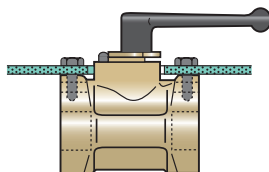

### Surface Mounting

With brackets and screws

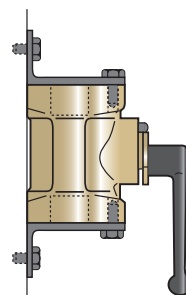

# High Pressure Series

**4402**

2/2 In-Line High Pressure Ball Valve, Female BSPP Thread



Treated brass, NBR

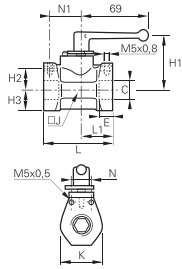

DN	C		E	H1	H2	H3	J	K	L	L1	N	N1	Kg
7	G1/4	<a href="#">4402 07 13</a>	12	50	13	15	30	30	58	25	15	20	0.402
10	G3/8	<a href="#">4402 10 17</a>	12	54	23	19	36	39	72	36	20	30	0.722
13	G1/2	<a href="#">4402 13 21</a>	15	56	23	21	40	42	79	36	20	30	0.870

# Ball Valves, Mini Series

With their **push-in connections**, these polymer lightweight ball valves allow for a significant reduction in installation time while offering **full flow capability** and **compact dimensions**.

## Product Advantages

**Optimum Solution**

- Full flow
- Marked with the pneumatic symbol for identification of its function
- Lightweight and compact
- Extremely compact, easy-to-operate lever
- Lever with screwdriver slot to facilitate operation
- Designed for polymer tubing with no tube preparation
- Can be mounted on a wall or adjacent using staples



**Proven Technology**

- LF 3000® push-in connection, excellent static and dynamic sealing
- High-strength polyamide
- Excellent long-term performance
- Automatic seal wear compensation for long-term reliability
- 100% leak-tested in production
- Date coding to guarantee quality and traceability

**Applications**  
 Robotics  
 Vacuum  
 Semi-Conductors  
 Packaging  
 Textile  
 Pneumatics

## Technical Characteristics

<b>Compatible Fluids</b>	Compressed air			
<b>Working Pressure</b>	Vacuum to 10 bar			
<b>Working Temperature</b>	-20°C to +80°C			

<b>Tightening Torques</b>	Threads	G1/8	G1/4	G3/8	G1/2
	daN.m	0.8	1.2	3	3.5

Reliable performance is dependent upon the type of fluid conveyed, component materials and tubing being used.  
 Guaranteed for use with a vacuum of 755 mm Hg (99 % vacuum).

### Component Materials

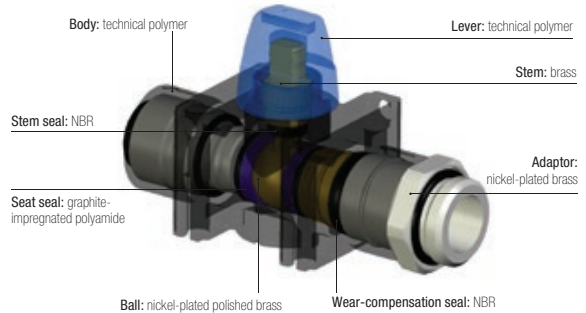

**Silicone-free**

## Operation

### Vented Valve, Open Position

3/2 model with vent

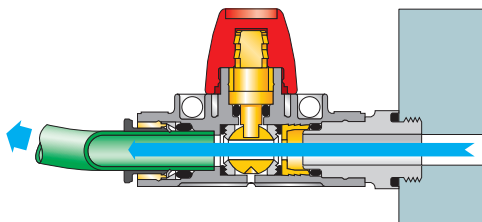

### Vented Valve, Closed Position

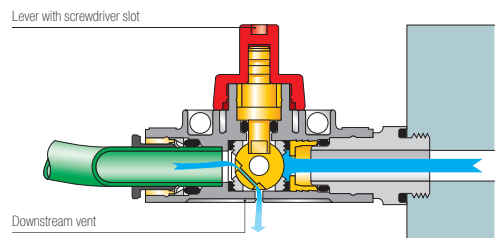

# Mini Series

## 7910 2/2 In-Line Mini-Ball Valve



Technical polymer, NBR

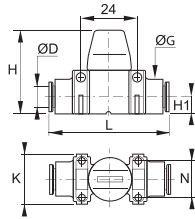

ØD		G	H	H1	K	L	N	Kg
4	<a href="#">7910 04 00</a>	15	37	7.5	22	51	16	0.039
6	<a href="#">7910 06 00</a>	15	37	7.5	22	52	16	0.034
8	<a href="#">7910 08 00</a>	15	37	7.5	22	52	16	0.025
10	<a href="#">7910 10 00</a>	20	43	11	30	66	22	0.060
12	<a href="#">7910 12 00</a>	20	43	11	30	66	22	0.040

## 7911 2/2 In-Line Mini-Ball Valve, Male BSPP Thread



Technical polymer, nickel-plated brass, NBR

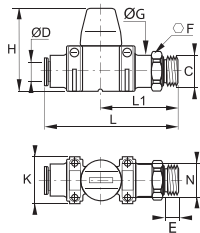

ØD	C		E	F	G	H	K	L	L1	N	Kg
6	G1/8	<a href="#">7911 06 10</a>	5	13	14	37	22	62	37	16	0.045
8	G1/4	<a href="#">7911 08 13</a>	5.5	16	17.5	37	22	61	35	16	0.040
10	G3/8	<a href="#">7911 10 17</a>	5.5	20	22	43	30	74	41	22	0.075
12	G1/2	<a href="#">7911 12 21</a>	7.5	24	26	43	30	75	42	22	0.075

## 7913 3/2 In-Line Mini-Ball Valve with Vent



Technical polymer, NBR

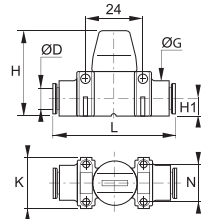

ØD		G	H	H1	K	L	N	Kg
4	<a href="#">7913 04 00</a>	15	37	7.5	22	51	16	0.040
6	<a href="#">7913 06 00</a>	15	37	7.5	22	52	16	0.035
8	<a href="#">7913 08 00</a>	15	37	7.5	22	52	16	0.025
10	<a href="#">7913 10 00</a>	20	43	11	30	66	22	0.060
12	<a href="#">7913 12 00</a>	20	43	11	30	66	22	0.045

## 7914 3/2 In-Line Mini-Ball Valve with Vent, Male BSPP Thread



Technical polymer, nickel-plated brass, NBR

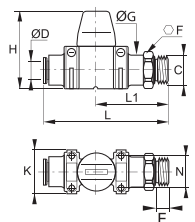

ØD	C		E	F	G	H	K	L	L1	N	Kg
6	G1/8	<a href="#">7914 06 10</a>	5	13	14	37	22	62	37	16	0.045
8	G1/4	<a href="#">7914 08 13</a>	5.5	16	17.5	37	22	61	35	16	0.040
10	G3/8	<a href="#">7914 10 17</a>	5.5	20	22	43	30	74	41	22	0.058
12	G1/2	<a href="#">7914 12 21</a>	7.5	24	26	43	30	75	42	22	0.075

## 7000 Joining Clips

Technical polymer



ØD		Kg
4	<a href="#">7000 00 05</a>	0.005
6	<a href="#">7000 00 05</a>	0.005
8	<a href="#">7000 00 05</a>	0.005
10	<a href="#">7000 00 06</a>	0.009
12	<a href="#">7000 00 06</a>	0.009

Ball Valves  
Industrial Valves

# LIQUIfit® Ball Valves

This range of valves offers an innovative solution in the treatment of **water and the handling of beverages** while protecting **health**. These **compact and reliable** valves offer perfect **sealing** and excellent **cleanliness**.

## Product Advantages

### Innovative Technology & Increased Reliability

- Full flow to limit turbulence
- Full-flow self-cleaning ball maintains the cleanliness of the circuit
- Tube retention with gripping ring prevents pumping effect
- Push-in connection and disconnection
- Sealing technology using patented EPDM seal

### High Performance

- Inert technical polymer providing the best mechanical strength, thermal and chemical resistance
- Carstick® connection providing resistance to water hammer
- Other configurations available on request



- Applications**
- Beverage Dispensers
  - Inert Gases
  - Cooling
  - Food Process
  - Water Purification
  - Water Coolers

## Technical Characteristics

<b>Compatible Fluids</b>	Water, drinks, beverages			
<b>Working Pressure</b>	0 to 10 bar at 20°C			
<b>Working Temperature</b>	-15°C to +100°C			
<b>Tightening Torques</b>	Threads	1/4" NPTF	3/8" NPTF	1/2" NPTF
	daN.m	1.5	3	3

### Component Materials

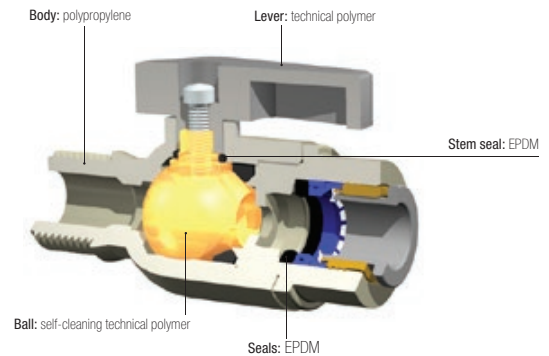

### Silicone-free

### Regulations

- FDA: 21 CFR
- NSF: 51 and lead < 0.25%
- WQA: Water Quality Association

# LIQUIfit® Ball Valves

## 4020 2/2 In-Line Ball Valve



Polypropylene with fibreglass, EPDM

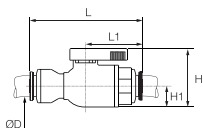

ØD		H	H1	L	L1	Kg
6	<a href="#">4020 06 00WP2</a>	36	13	57	27	0.019
8	<a href="#">4020 08 00WP2</a>	36	13	60	27	0.020
10	<a href="#">4020 10 00WP2</a>	36	13	70	33	0.023
12	<a href="#">4020 12 00WP2</a>	36.5	13	88	43	0.034

## 4020 2/2 In-Line Ball Valve

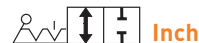

Polypropylene with fibreglass, EPDM

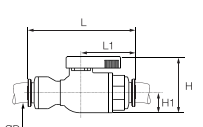

ØD		H	H1	L	L1	Kg
1/4	<a href="#">4020 56 00WP2</a>	25	13	65	31	0.025
3/8	<a href="#">4020 60 00WP2</a>	36	13	68	30.5	0.034

## 4021 2/2 In-Line Ball Valve, Male NPTF Thread

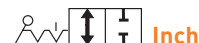

Polypropylene with fibreglass, EPDM

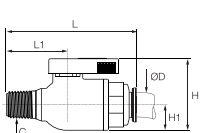

ØD	C		H	H1	L	L1	Kg
1/4	NPTF1/4	<a href="#">4021 56 14WP2</a>	36	13	61	31	0.029
3/8	NPTF3/8	<a href="#">4021 60 18WP2</a>	36	13	64	33.5	0.028

## 4023 2/2 In-Line Ball Valve, Female NPTF Thread



Polypropylene with fibreglass, EPDM

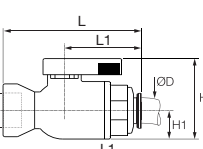

ØD	C		H	H1	L	L1	Kg
1/4	NPTF1/4	<a href="#">4023 56 14WP2</a>	36	13	58	31	0.025
3/8	NPTF3/8	<a href="#">4023 60 18WP2</a>	36	13	64	33.5	0.028

## 4022 2/2 Right- Angled Ball Valve, Female NPTF Thread



Polypropylene with fibreglass, EPDM

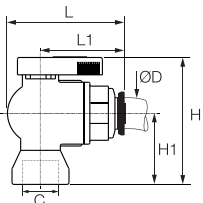

ØD	C		H	H1	L	L1	Kg
1/4	NPTF1/4	<a href="#">4022 56 14WP2</a>	52	29	44	31	0.026
3/8	NPTF3/8	<a href="#">4022 60 18WP2</a>	52	29	47	33.5	0.031

## 4024 2/2 Right- Angled Ball Valve



Polypropylene with fibreglass, EPDM

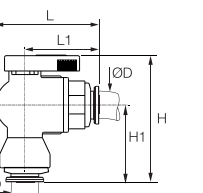

ØD		H	H1	L	L1	Kg
6	<a href="#">4024 06 00WP2</a>	54	31	41	27	0.020
8	<a href="#">4024 08 00WP2</a>	56	33	41	27.5	0.020
10	<a href="#">4024 10 00WP2</a>	61	38	47	33	0.024
12	<a href="#">4024 12 00WP2</a>	63	40	57	43	0.031



# Needle and Butterfly Valve Range

## Brass Needle Valves

### In-Line

**0502**  
Page 6-39



**0501**  
Page 6-39



**0510**  
Page 6-39



### Right-Angled

**0532**  
Page 6-39



**0531**  
Page 6-39



### Drain Valve

**0562**  
BSPP/Metric  
Page 6-40



**0563**  
NPT  
Page 6-40



### Venting Pressure Gauge Valve

**0627**  
BSPP  
Page 6-40



### Pressure Relief Valve

**0630**  
BSPP  
Page 6-40



## Stainless Steel Needle Valve

### In-Line

**0591**  
Page 6-41



## Butterfly Valve

### In-Line

**4602**  
Page 6-43



# Needle Valves

Parker Legris compact needle valves can be installed in any system and are designed for applications requiring accurate **leak-free fluid control** and **excellent service life**.

## Product Advantages

- Robust and Easy-to-Use**
  - Accurate flow control
  - Forged brass for improved long-term mechanical strength
  - Robust stem for good operational reliability
  - Corrosion resistance
  
- Wide Range**
  - Two materials (nickel-plated brass and stainless steel) suitable for many applications
  - Numerous valve and safety accessory configurations



Pneumatics  
 Water Circuits  
 Machine Tools  
 Rubber Industry  
 Packaging  
 Textile

Applications

## Technical Characteristics

	Brass	Stainless Steel
<b>Compatible Fluids</b>	Compressed air, water, industrial fluids, etc. Other fluids: contact us	Many fluids
<b>Working Pressure</b>	0 to 120 bar	0 to 400 bar
<b>Working Temperature</b>	-20°C to +100°C (except model 0510)	-20°C to +180°C

Tightening Torques	Threads	G1/8	G1/4	G3/8	G1/2
	daN.m	0.10 to 0.20	0.10 to 0.20	0.15 to 0.25	0.20 to 0.35

Reliable performance is dependent upon the type of fluid conveyed.

### Component Materials

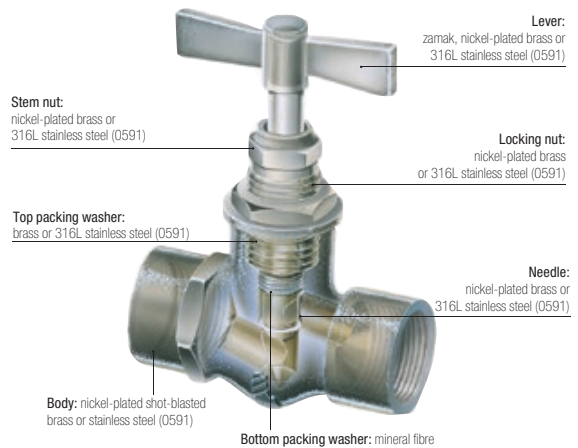

### Silicone-free

### Regulations

- DI: 97/23/EC (module PED A - diameters greater than 25 mm)
- DI: 2006/42/EC (Machinery Directive)
- DI: 2002/95/EC (RoHS)
- RG: 1907/2006 (REACH)

# Brass Needle Valves

## 0502 In-Line Needle Valve, Female BSPP Thread



Nickel-plated brass

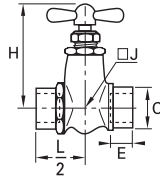



DN	C		E	H	H <sub>max</sub>	J	L/2	Kg
4	G1/8	<a href="#">0502 04 10</a>	9	56	50	17	23	0.133
	G1/4	<a href="#">0502 04 13</a>	11	56	50	17	23	0.118
6	G3/8	<a href="#">0502 06 17</a>	12	67	60	-	26	0.171
9	G3/8	<a href="#">0502 09 17</a>	12	82	70	-	33	0.426

## 0501 In-Line Needle Valve, Male/Female BSPP Thread

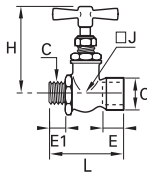

Nickel-plated brass





DN	C		E	E1	H	H <sub>max</sub>	J	L	Kg
4	G1/8	<a href="#">0501 04 10</a>	9	7	56	50	17	44	0.118
	G1/4	<a href="#">0501 04 13</a>	11	9.5	56	50	17	46	0.115
6	G3/8	<a href="#">0501 06 17</a>	12	9.5	67	60	-	48	0.158

## 0510 In-Line Needle Valve with Compression Connections

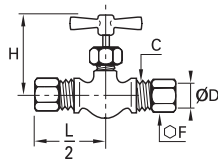

Nickel-plated brass



DN	ØD	C		F	H <sub>min</sub>	H <sub>max</sub>	L/2	Kg
4	6	M10x1	<a href="#">0510 04 06</a>	13	42	46	29	0.083
8	8	M12x1	<a href="#">0510 05 08</a>	14	42	46	30	0.083
5	10	M16x1.5	<a href="#">0510 05 10</a>	19	42	46	31	0.111

The needle is sealed by an O-ring.

Maximum operating pressure: Ø4: 100 bar, Ø5: 60 bar

Working temperature: -15°C to +70°C

Tightening torques: please refer to the Compression Fittings chapter of this catalogue.

## 0532 Right-Angle Needle Valve, Female BSPP Thread



Nickel-plated brass

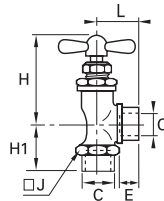



DN	C		E	H <sub>min</sub>	H <sub>max</sub>	H1	J	L	Kg
4	G1/8	<a href="#">0532 04 10</a>	9	46	52	19	17	19	0.093
	G1/4	<a href="#">0532 04 13</a>	11	46	52	21	17	21	0.087
6	G1/4	<a href="#">0532 06 13</a>	11	55	63	26	22	26	0.171

## 0531 Right-Angle Needle Valve, Male/Female BSPP Thread

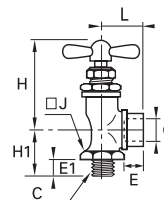

Nickel-plated brass





DN	C		E	E1	H <sub>min</sub>	H <sub>max</sub>	H1	J	L	Kg
4	G1/8	<a href="#">0531 04 10</a>	7	9	46	52	19	17	19	0.082
	G1/4	<a href="#">0531 04 13</a>	9.5	11	46	52	21	17	21	0.090
6	G1/4	<a href="#">0531 06 13</a>	9.5	11	55	63	25	22	26	0.155
	G3/8	<a href="#">0531 06 17</a>	9.5	12	55	63	25	22	27	0.153
10	G1/2	<a href="#">0531 10 21</a>	13	16	62	72	34	26	33	0.329

# Brass Needle Valves

## 0562 Needle Drain Valve, Male BSPP and Metric Thread

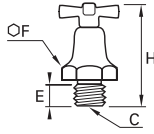
Brass



DN	C		E	F	H min	H max	Kg
	M10x1	0562 05 60	8	16	37.5	40	0.031
5	G1/8	0562 05 10	8	16	36	40	0.032
	G1/4	0562 05 13	10	19	38.5	42.5	0.040

## 0563 Needle Drain Valve, Male NPT Thread

Brass

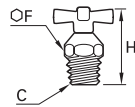

DN	C		F	H min	H max	Kg
5	G1/4	0563 05 14	14	28.5	32.5	0.021

## 0627 Automatic Vent Pressure Gauge Valve, Female BSPP Thread

Nickel-plated brass, NBR

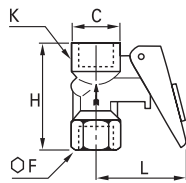

C		F	H	K	L	Kg
G1/4	0627 00 13	19	43.5	20	40	0.097

Pressure: 10 bar

This isolating valve is used to connect a pressure gauge to a circuit.

Resetting the lever isolates and vents the gauge.

A locking pin can be used to enable the gauge to be fitted permanently.

## 0630 Pressure Relief Valve, Male BSPP Thread

Brass

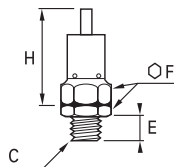

C		E	F	H	Kg
G1/4	0630 06 13	9	17	42.5	0.050

This valve is delivered without calibration, but can be adjusted by inserting metal washers into the hexagon (F).

Maximum working pressure: 10 bar

Calibration from 1 to 10 bar (not below)

# Stainless Steel Needle Valves

## 0591 Needle Valve, Female BSPP Thread



Stainless steel 316L, PTFE

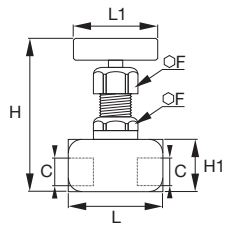

DN	C		F	H min	H max	H1	L	L1	Kg
3	G1/8	0591 03 10	22	90	99	25	45	48	0.345
4	G1/4	0591 04 13	22	90	99	25	50	48	0.355
5	G3/8	0591 05 17	22	90	104	30	56	48	0.430
6	G1/2	0591 06 21	22	90	104	30	62	48	0.483

# Butterfly Valves

In these robust valves, the internal component used to shut off the flow is a segment of a sphere. This allows **frequent operation with very low torque, no fluid retention areas** and therefore excellent mechanical performance.

## Product Advantages

### Compact & Abrasion-Resistant

- Excellent with abrasive fluids (including solid particles)
- Fluid flow direction marked for greater safety (uni-directional)
- Smooth operation
- Can be easily adapted for use with auxiliary actuators
- More compact than a ball valve with equivalent nominal diameter
- Simple and efficient design for a long service life

### Applications

- Painting & Printing
- Machine Tools
- Pneumatics
- Powder Conveyance
- Plumbing
- Rubber Industry
- Petrochemical

## Technical Characteristics

<b>Compatible Fluids</b>	Compressed air, industrial gases, water, cutting oils, hydraulic oils, fuel oil, fuel, etc.
<b>Working Pressure</b>	0 to 16 bar
<b>Working Temperature</b>	-20°C to +80°C

Reliable performance is dependent upon the type of fluid conveyed.

### Component Materials

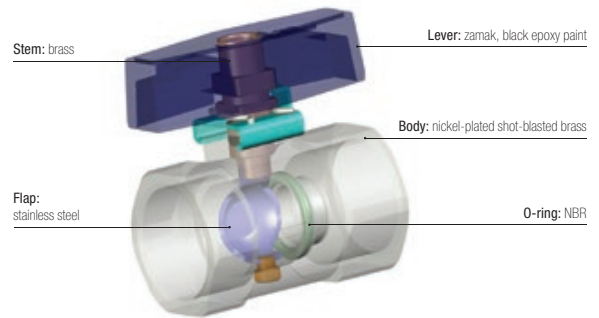

### Silicone-free

### Regulations

- DI: 97/23/EC (module PED A - diameters greater than 25 mm)
- DI: 2006/42/EC (Machinery Directive)
- DI: 2002/95/EC (RoHS)
- RG: 1907/2006 (REACH)

# Butterfly Valves

## 4602 2/2 Butterfly Shut-Off Valve, Female BSPP Thread



Nickel-plated brass, NBR

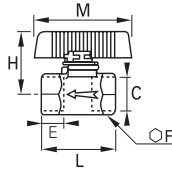

DN	C		E	F	H	L	M	Kg
6	G1/4	<a href="#">4602 06 13</a>	9	17	35	34	54	0.102
7	G3/8	<a href="#">4602 07 17</a>	11	22	35	39	54	0.136
10	G1/2	<a href="#">4602 10 21</a>	12	24	37	42	54	0.140
13	G3/4	<a href="#">4602 13 27</a>	14	30	40	49	54	0.208
18	G1	<a href="#">4602 18 34</a>	15	41	46	55	54	0.412

Black epoxy-coated zamak handle

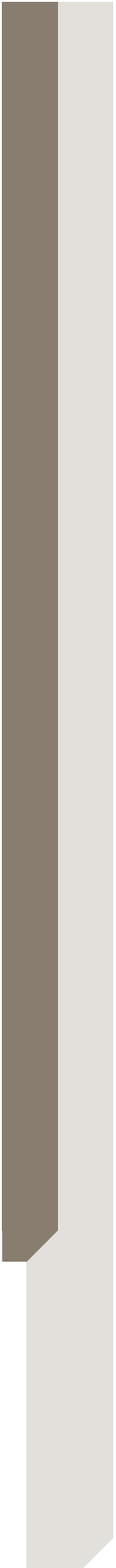

# Axial Valve Range

## In-Line Normally Closed

**4202..20**  
FKM Seal  
2/2  
Page 6-48



**4202..30**  
EPDM Seal  
2/2  
Page 6-48



## In-Line Normally Open

**4212..20**  
FKM Seal  
2/2  
Page 6-48



**4212..30**  
EPDM Seal  
2/2  
Page 6-48



## In-Line Double-Acting

**4222..20**  
FKM Seal  
2/2  
Page 6-48



**4222..30**  
EPDM Seal  
2/2  
Page 6-49



## Accessories

**4298**  
Sub-Base  
Page 6-49



**4298**  
Solenoid Valve  
Page 6-49



**4299**  
Pneumatic Button  
Page 6-49



# Axial Valves

The Parker Legris axial valve is the only valve to incorporate both the **valve and actuation function**. With pneumatic or electro-pneumatic control, it avoids many of the restrictions associated with traditional actuators.

## Product Advantages

**Optimisation & Safety**

- Very compact: up to 50% smaller than valves with separate actuators
- Simple to install: ready-to-use
- Common sub-base for solenoid control
- Automation of the open/close function
- Operation independent of the upstream and downstream pressure in the circuit

**Comprehensive Offer**

- Two seal materials for a wider chemical and temperature range
- Pneumatic, electro-pneumatic or dual actuation control
- Three versions: normally closed, normally open and double-acting

**Performance**

- Full flow: low pressure drop
- Excellent pressure/temperature performance
- Compatible with many industrial fluids



**Applications**

- Flow Control
- Plastic Injection Moulding
- Rubber Industry
- Pneumatics
- Textile
- Printing
- Packaging
- Robotics

## Technical Characteristics

<b>Compatible Fluids</b>	Depending on type of seal – FKM: water, air, oils, greases, etc. – EPDM: hot water, air, steam, etc.
<b>Working Pressure</b>	10 bar max.
<b>Pilot Pressure</b>	NC and NO: 4.2 to 8 bar Double-acting: 3 to 8 bar
<b>Working Temperature</b>	-20°C to +135°C (suffix 20 FKM) -20°C to +120°C (suffix 30 EPDM)

<b>Tightening Torques</b>	Threads	G3/8	G1/2	G3/4	G1	G1¼	G1½	G2
	daN.m	0.15 to 0.25	0.20 to 0.35	0.50 to 0.70	0.50 to 0.70	0.40 to 0.60	0.80 to 1.20	0.80 to 1.20

Reliable performance is dependent upon the type of fluid conveyed, component materials and tubing being used.  
 Guaranteed for use with a vacuum of 740 mm Hg (97% vacuum).

### Flow Curve and Pressure Drop (Kv)

**Kv in m³/h** (ambient water temperature, under a differential pressure of 1 bar)

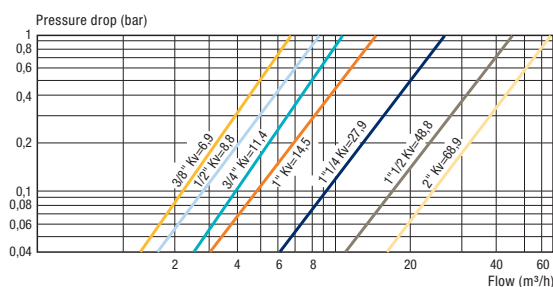

### Component Materials

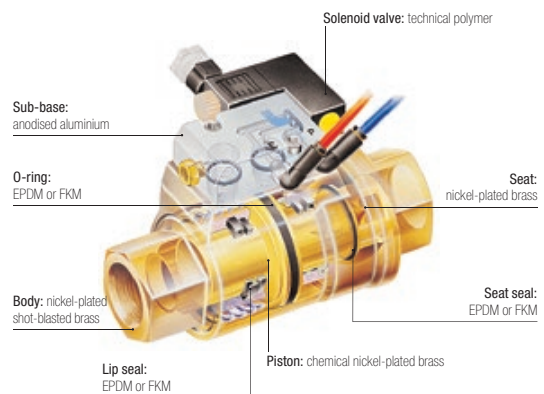

### Silicone-free

### Regulations

- DI: 97/23/EC (module PED A - diameters greater than 25 mm)
- DI: 2006/42/EC (Machinery Directive)
- DI: 2002/95/EC (RoHS)
- RG: 1907/2006 (REACH)
- DI: 94/9/EC (ATEX) - for pneumatic operation versions

# Axial Valves

## Operation

Depending on operational requirement, air is passed into the actuation chamber to open or close the valve.

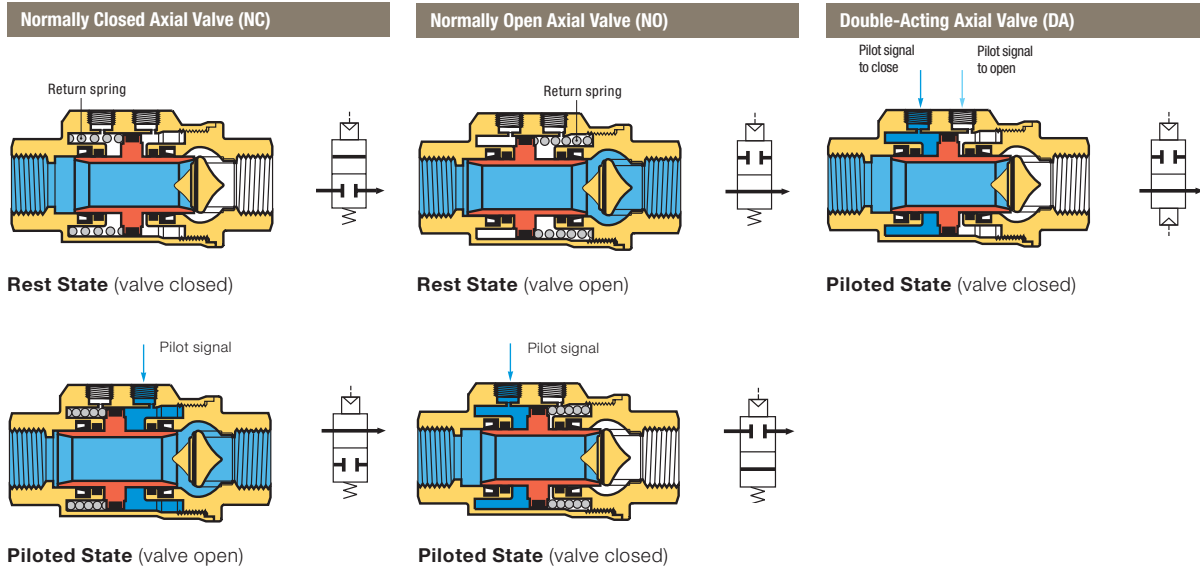

## Installation Options

The Parker Legris axial valve offers 3 different control methods dependant on the requirements of the installation:

### Pneumatic Control

**Example:** Double-acting axial valve 4222

- local compressed air control
- for repetitive on/off cycles
- remote control where access to the machine is difficult
- for explosive or explosion prevention areas

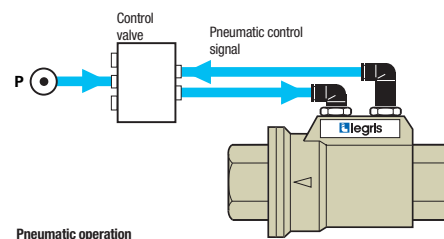

### Electro-Pneumatic Control

**Example:** Normally closed axial valve 4202  
+ sub-base and Mini-solenoid valve 4298

- for automated industrial systems requiring remote control
- Namur seating plane solenoid valve

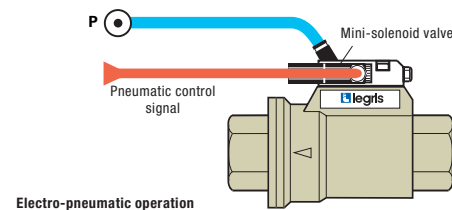

### Dual Pneumatic and Electro-Pneumatic Control

**Example:** Normally open axial valve 4212  
+ sub-base and Mini-solenoid valve 4298  
+ Pneumatic push-button 4299

- dual control structure
- for increased safety: prevents localised operating errors
- Namur seating plane solenoid valve

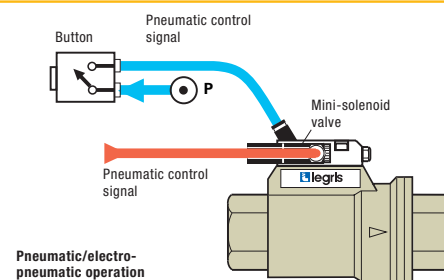

# Axial Valves

## 4202..20 Normally Closed Axial Valve with FKM Seal, Female BSPP Thread

Nickel-plated brass, FKM

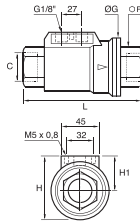

C		F	G	H	H1	L	Kg
G3/8	<a href="#">4202 10 17 20</a>	22	46	54	31	98	0.815
G1/2	<a href="#">4202 15 21 20</a>	27	52	60	35	112	1.093
G3/4	<a href="#">4202 20 27 20</a>	33	64	70	38	135	1.624
G1	<a href="#">4202 25 34 20</a>	41	69	76	41.5	143	2.033
G1 1/4	<a href="#">4202 32 42 20*</a>	50	86	91	48	165	3.266
G1 1/2	<a href="#">4202 40 49 20*</a>	60	96	102	54	180	4.195
G2	<a href="#">4202 50 48 20*</a>	75	109	115	60.5	207	6.465

Pilot port: G1/8

Complete with M5 silencer

\*Models with EC marking

## 4202..30 Normally Closed Axial Valve with EPDM seal, Female BSPP Thread

Nickel-plated brass, EPDM

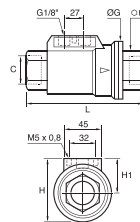

C		F	G	H	H1	L	Kg
G3/8	<a href="#">4202 10 17 30</a>	22	46	54	31	98	0.828
G1/2	<a href="#">4202 15 21 30</a>	27	52	60	35	112	1.097
G3/4	<a href="#">4202 20 27 30</a>	33	64	70	38	135	1.606
G1	<a href="#">4202 25 34 30</a>	41	69	76	41.5	143	2.013
G1 1/4	<a href="#">4202 32 42 30*</a>	50	86	91	48	165	3.315
G1 1/2	<a href="#">4202 40 49 30*</a>	60	96	102	54	180	4.195
G2	<a href="#">4202 50 48 30*</a>	75	109	115	60.5	207	6.360

Pilot port: G1/8

Delivered with a silencer

\*Models with EC marking

## 4212..20 Normally Open Axial Valve with FKM Seal, Female BSPP Thread

Nickel-plated brass, FKM

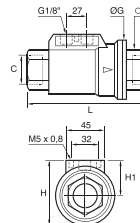

C		F	G	H	H1	L	Kg
G3/8	<a href="#">4212 10 17 20</a>	22	46	54	31	98	0.828
G1/2	<a href="#">4212 15 21 20</a>	27	52	60	35	112	1.096
G3/4	<a href="#">4212 20 27 20</a>	33	64	70	38	135	1.637
G1	<a href="#">4212 25 34 20</a>	41	69	76	41.5	143	2.025
G1 1/4	<a href="#">4212 32 42 20*</a>	50	86	91	48	165	3.301
G1 1/2	<a href="#">4212 40 49 20*</a>	60	96	102	54	180	4.188
G2	<a href="#">4212 50 48 20*</a>	75	109	115	60.5	207	6.555

Pilot port: G1/8

Complete with M5 silencer

\*Models with EC marking

## 4212..30 Normally Open Axial Valve with EPDM seal, Female BSPP Thread

Nickel-plated brass, EPDM

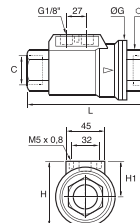

C		F	G	H	H1	L	Kg
G3/8	<a href="#">4212 10 17 30</a>	22	46	54	31	98	0.827
G1/2	<a href="#">4212 15 21 30</a>	27	52	60	35	112	1.152
G3/4	<a href="#">4212 20 27 30</a>	33	64	70	38	135	1.595
G1	<a href="#">4212 25 34 30</a>	41	69	76	41.5	143	1.993
G1 1/4	<a href="#">4212 32 42 30*</a>	50	86	91	48	165	3.301
G1 1/2	<a href="#">4212 40 49 30</a>	60	96	102	54	180	4.775
G2	<a href="#">4212 50 48 30*</a>	75	109	115	60.5	207	6.360

Pilot port: G1/8

Delivered with a silencer

\*Models with EC marking

# Axial Valves

## 4222..20 Double-Acting Axial Valve with FKM Seal, Female BSPP Thread

Nickel-plated brass, FKM

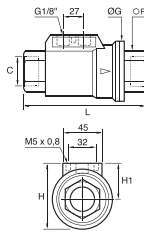

C		F	G	H	H1	L	Kg
G3/8	<a href="#">4222 10 17 20</a>	22	46	54	31	98	0.802
G1/2	<a href="#">4222 15 21 20</a>	27	52	60	35	112	1.050
G3/4	<a href="#">4222 20 27 20</a>	33	64	70	38	135	1.571
G1	<a href="#">4222 25 34 20</a>	41	69	76	41.5	143	1.942
G1 1/4	<a href="#">4222 32 42 20*</a>	50	86	91	48	165	3.058
G1 1/2	<a href="#">4222 40 49 20*</a>	60	96	102	54	180	3.995
G2	<a href="#">4222 50 48 20*</a>	75	109	115	60.5	207	6.275

Pilot port: G1/8

\*Models with EC marking

## 4222..30 Double-Acting Axial Valve with EPDM seal, Female BSPP Thread

Nickel-plated brass, EPDM

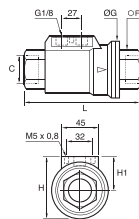

C		F	G	H	H1	L	Kg
G3/8	<a href="#">4222 10 17 30</a>	22	46	54	31	98	0.832
G1/2	<a href="#">4222 15 21 30</a>	27	52	60	35	112	1.046
G3/4	<a href="#">4222 20 27 30</a>	33	64	70	38	135	1.662
G1	<a href="#">4222 25 34 30</a>	41	69	76	41.5	143	1.943
G1 1/4	<a href="#">4222 32 42 30*</a>	50	86	91	48	165	3.301
G1 1/2	<a href="#">4222 40 49 30*</a>	60	96	102	54	180	4.260
G2	<a href="#">4222 50 48 30*</a>	75	109	115	60.5	207	6.520

Pilot port: G1/8

Delivered with a silencer

\*Models with EC marking

## 4298 Sub-Base for Solenoid Pilot Valve

Treated aluminium, NBR

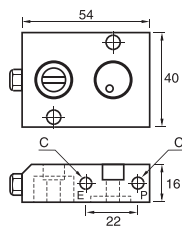

C		Kg
M5x0.8	<a href="#">4298 00 01</a>	0.095

The sub-base is fitted directly to the axial valve and allows the mounting of a 15x15 solenoid valve. Supplied with 2 fixing bolts, silencer and seats.

## 4298 Mini-Solenoid Valve 1W/12VA

Anodised aluminium

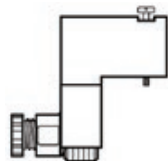

Voltage		Kg
24V = CC*	<a href="#">4298 01 01</a>	0.051
24V ~ CA**	<a href="#">4298 01 02</a>	0.058
110V ~ CA**	<a href="#">4298 02 01</a>	0.051
220V ~ CA**	<a href="#">4298 02 02</a>	0.054

\*Direct current

\*\*Alternating current

## 4299 Pneumatic Button/Electro-Pneumatic

Nickel-plated brass, technical polymer

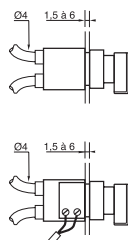

Contact		Kg
Standard*	<a href="#">4299 01 01</a>	0.090
With key*	<a href="#">4299 01 02</a>	0.110
Standard**	<a href="#">4299 02 01</a>	0.102
With key**	<a href="#">4299 02 02</a>	0.124

Bulkhead fixing hole diameter: Ø22 mm

\*1 pneumatic contact

\*\*1 electro-pneumatic contact

Available upon request