



**HANLEY CONTROLS**

CLONMEL

[www.hccl.ie](http://www.hccl.ie)



aerospace  
climate control  
electromechanical  
filtration  
fluid & gas handling  
hydraulics  
**pneumatics**  
process control  
sealing & shielding



# P3Z Series Air preparation system

1 1/2" & 2" Body Ported, Modular SAE Blocks

Catalogue no. PDE2641TCUK - January 2020



ENGINEERING YOUR SUCCESS.

Filter / Dust Filter .....	4 - 5
Coalescing Filter / Adsorber Filter .....	6 - 7
Regulator / Pilot Regulator .....	8 - 9
Lubricator .....	10 - 11
Modular Manifold .....	12
Connection Flange Kits .....	12
Accessories .....	13

 **WARNING**

FAILURE OR IMPROPER SELECTION OR IMPROPER USE OF THE PRODUCTS AND/OR SYSTEMS DESCRIBED HEREIN OR RELATED ITEMS CAN CAUSE DEATH, PERSONAL INJURY AND PROPERTY DAMAGE.

This document and other information from Parker Hannifin Corporation, its subsidiaries and authorized distributors provide product and/or system options for further investigation by users having technical expertise. It is important that you analyze all aspects of your application and review the information concerning the product or system in the current product catalog. Due to the variety of operating conditions and applications for these products or systems, the user, through its own analysis and testing, is solely responsible for making the final selection of the products and systems and assuring that all performance, safety and warning requirements of the application are met. The products described herein, including without limitation, product features, specifications, designs, availability and pricing, are subject to change by Parker Hannifin Corporation and its subsidiaries at any time without notice.

**SALE CONDITIONS**

The items described in this document are available for sale by Parker Hannifin Corporation, its subsidiaries or its authorized distributors. Any sale contract entered into by Parker will be governed by the provisions stated in Parker's standard terms and conditions of sale (copy available upon request).

**The System**

The all metal P3Z system allows units to be connected to most medium sized ring main installations by the use of either 1-1/2" or 2" flanges.

The P3Z Filters are specially designed to efficiently filter out rust, dirt, moisture and other impurities from compressed air lines. Operation is fully automatic with a minimum of pressure drop. Coalescing filters and adsorber filters for high purity air are also included in the P3Z series.

The P3Z Regulators are designed to provide quick response and accurate pressure regulation for the most demanding hi-flow industrial applications. The rolling diaphragm was designed for long trouble-free operation and will not rupture or tear under high cycle or other demanding applications.

The P3Z mist lubricators are designed to provide lubrication for many general purpose applications in a pneumatic system.

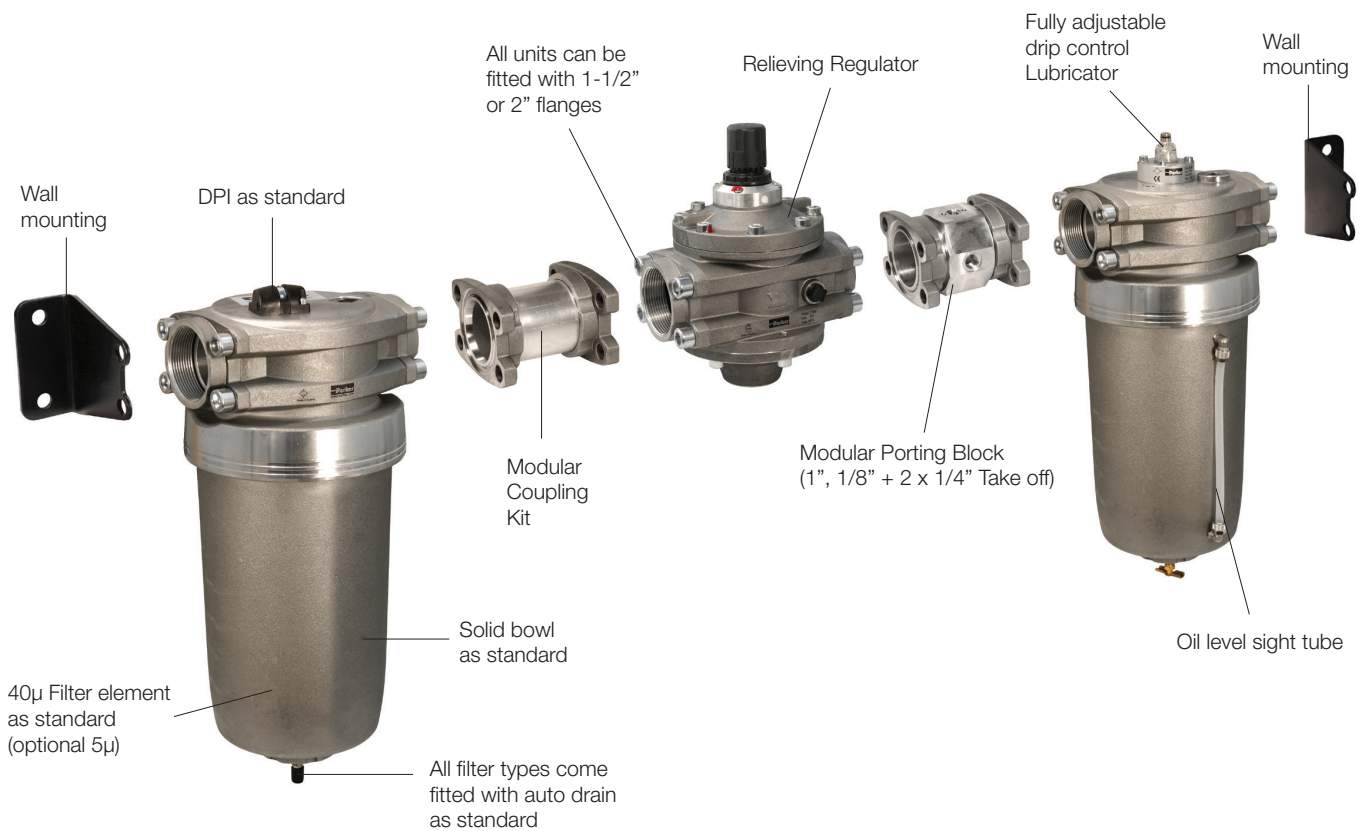

**Filter-Regulator - Dust Filter-Adsorber**

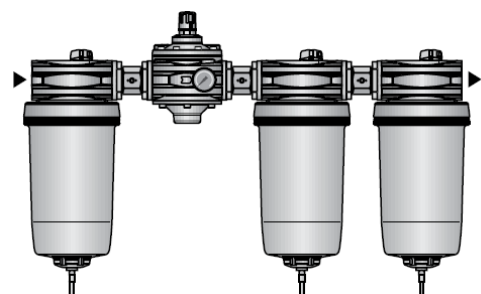

**Filter / Dust Filter**

**Symbols**

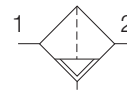

Auto drain

- Flanged 1-1/2" or 2" (BSPP & NPT)
- High efficiency particulate element as standard
- Excellent water removal efficiency
- Robust die-cast aluminium construction
- Standard DPI for monitoring (0.5 - 0.8 bar)

**Note:** To optimise the life of the dust 1µm element, it is advisable to install a P3ZFA pre-filter with a 5 micron element upstream of the coalescing filter.

**Options:**

<b>P 3 Z F A</b>	□	□	□	<b>M A</b>	<b>N</b>
SAE Mtg - No thread	<b>0</b>	None	<b>0</b>	40 Micron Element + DPI Standard	<b>H</b>
BSPP flange	<b>1</b>	1-1/2"	<b>B</b>	5 Micron Element + DPI Optional	<b>F</b>
NPT flange	<b>9</b>	2"	<b>C</b>	1 Micron Element + DPI	<b>M</b>
				Auto Drain	<b>MA</b>

Port size	Description	Order Code	Flow dm <sup>3</sup> /s *	Max bar	Min temp °C	Max temp °C	Bowl capacity cm <sup>3</sup>	Height mm	Width mm	Depth mm	Weight kg
-	40 micron, auto drain	<b>P3ZFA00HMAN</b>	>666	17.5	0	60	600	445	200	182	6.3
1-1/2"	40 micron, auto drain	<b>P3ZFA1BHMAN</b>	>666	17.5	0	60	600	445	200	182	6.3
2"	40 micron, auto drain	<b>P3ZFA1CHMAN</b>	>666	17.5	0	60	600	445	200	182	6.3
-	1 micron, auto drain	<b>P3ZFA00MMAN</b>	>666	17.5	0	60	600	445	200	182	6.3
1-1/2"	1 micron, auto drain	<b>P3ZFA1BMMAN</b>	>666	17.5	0	60	600	445	200	182	6.3
2"	1 micron, auto drain	<b>P3ZFA1CMMAN</b>	>666	17.5	0	60	600	445	200	182	6.3

\* flow with 6,3 bar inlet pressure and 0,5 pressure drop.

### Technical Information

Fluid:	Compressed air
Maximum inlet pressure*:	17.5 bar
Temperature range*:	0°C to +60°C
Particle removal:	40 & 5 micron
Air quality:	Within ISO 8573-1 : 1991 Class 3 and 5 (particulates) Within ISO 8573-1 : 2001 Class 6 and 7 (particulates)
Typical flow with 40µm element 6,3 bar inlet pressure and 0.5 bar pressure drop:	666 dm <sup>3</sup> /s
Auto drain: bowl pressure to close drain Operating range manual override facility (depress pin)	0.8 bar 0.8 to 17.5 bar Ø 10mm brass connection
Bowl sump capacity:	600 cm <sup>3</sup>

\* Air supply must be dry enough to avoid ice formation at temperatures below +2°C

### Material Specification

Body:	Aluminium
Element:	Sintered P.E.
Seals:	Nitrile NBR
Drains: Automatic:	PA / Brass connection
Differential pressure indicator materials:	
Body:	Acetal
Internal parts:	Acetal
Spring:	Stainless steel
Seals:	Nitrile NBR
Support plate	ABS
Screws	Steel / zinc plated

### Dimensions (mm)

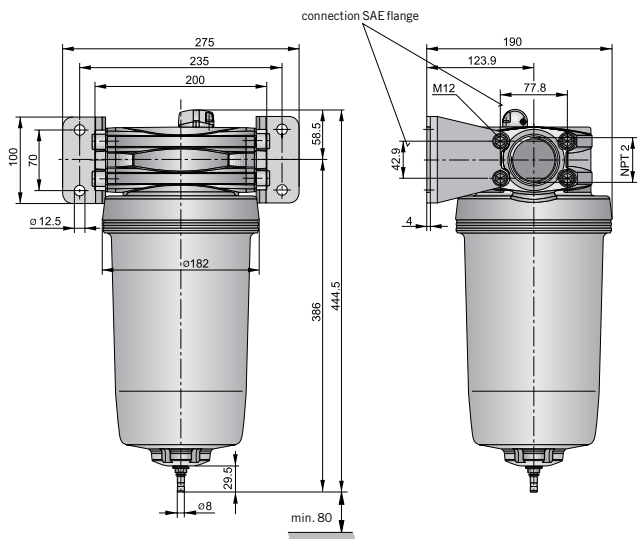

### Flow characteristics

#### (2") 40 Micron Filter

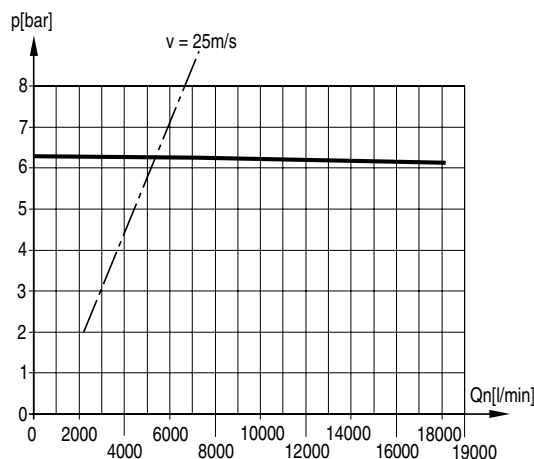

### Service kits

Description	Order code
5 micron element kit	<b>P3ZKA00ESE</b>
40 micron element kit	<b>P3ZKA00ESG</b>
1 micron element kit	<b>P3ZKA00ES9</b>

**Coalescing Filter / Adsorber Filter**



- Extended high efficiency filter element provides greater filtration surface area.
- Flanged 1-1/2" or 2" (BSPP & NPT)
- Removes liquid aerosols and sub micron particles
- Oil free air for critical applications, such as air gauging, pneumatic instrumentation and control

**Note:** To optimise the life of the coalescing element, it is advisable to install a P3ZFA pre-filter with a 5µm filter upstream of the coalescing filter.

**Note:** To optimise the life of the adsorber element, it is advisable to install a P3ZFA coalescing 0.01µm filter upstream of the adsorber filter.

**Options:**

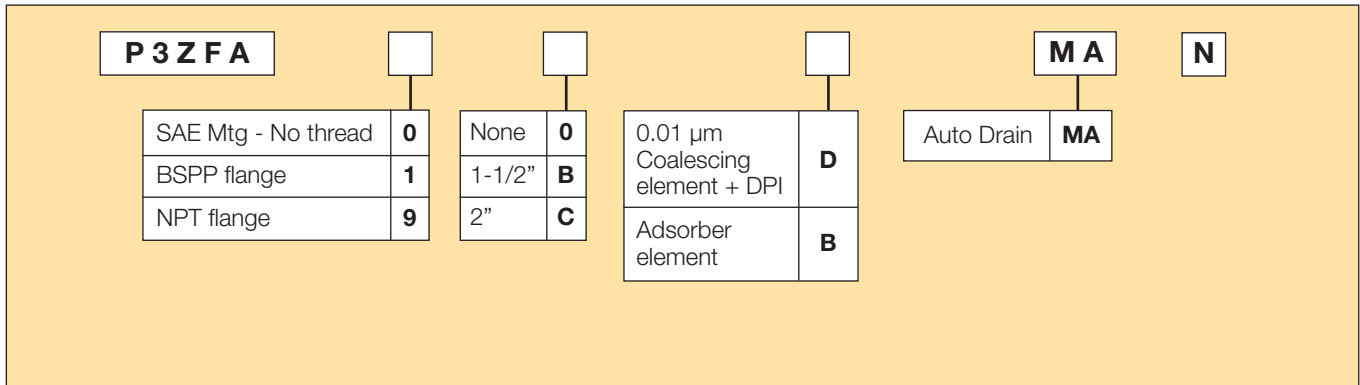

Port size	Description	Order Code	Flow dm <sup>3</sup> /s *	Max bar	Min temp °C	Max temp °C	Bowl capacity cm <sup>3</sup>	Height mm	Width mm	Depth mm	Weight kg
-	Coalescing filter 0.01 µm auto drain	<b>P3ZFA00DMAN</b>	>167	17.5	0	60	600	445	200	182	6.4
1-1/2"	Coalescing filter 0.01 µm auto drain	<b>P3ZFA1BDMAN</b>	>167	17.5	0	60	600	445	200	182	6.4
2"	Coalescing filter 0.01 µm auto drain	<b>P3ZFA1CDMAN</b>	>167	17.5	0	60	600	445	200	182	6.4
-	Adsorber filter	<b>P3ZFA00BMAN</b>	>167	17.5	0	60	600	445	200	182	6.4
1-1/2"	Adsorber filter	<b>P3ZFA1BBMAN</b>	>167	17.5	0	60	600	445	200	182	6.4
2"	Adsorber filter	<b>P3ZFA1CBMAN</b>	>167	17.5	0	60	600	445	200	182	6.4

\* flow with 6,3 bar inlet pressure and 0,5 pressure drop.

**Technical Information**

Fluid:	Compressed air
Maximum inlet pressure*:	17.5 bar
Temperature range*:	0°C to +60°C
Media specifications:	
Coalescing efficiency	(0.3 to 0.6 micron particles): 99.97%
Max. oil carryover (PPM w/w):	0.008 mg/m <sup>3</sup>
Typical flow element @ 6,3 bar inlet pressure and 0.2 bar pressure drop:	Dry element 0.01µm @ dm <sup>3</sup> /s
Auto drain:	
bowl pressure to close drain	0.8 bar
Operating range	0.8 to 17.5 bar
manual override facility (depress pin)	Ø 10mm brass connection
Bowl sump capacity:	600 cm <sup>3</sup>

\* Air supply must be dry enough to avoid ice formation at temperatures below +2°C

**Material Specification**

Body:	Aluminium
Filter cover:	ABS
Coalescing element:	Borosilicate & Nano fibres
Top & bottom end cap:	Aluminium
Support cylinders:	Grade 430 stainless steel
Support media:	Polypropylene
Anti re-entrainment barrier:	Polyester
Ensapulate:	Epoxy resin / Hardener
Seals:	Nitrile NBR
Drains:	Automatic: PA / Brass connection

Differential pressure indicator materials:

Body:	Acetal
Internal parts:	Acetal
Spring:	Stainless steel
Seals:	Nitrile NBR
Support plate	ABS
Screws	Steel / zinc plated

**Dimensions (mm)**

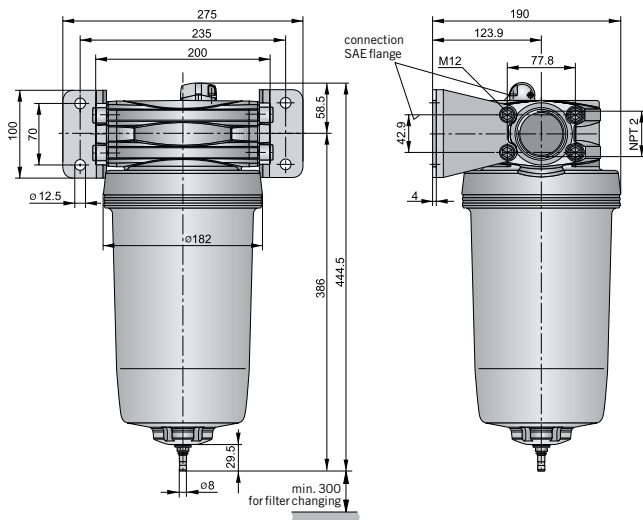

**Flow characteristics**

**(2") 0.01µm Coalescing Filter Saturated**

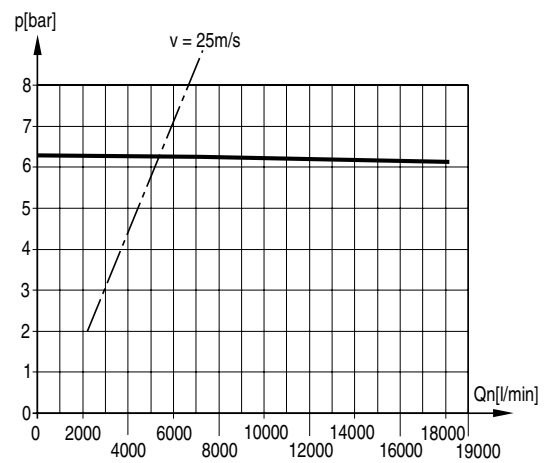

**Service kits**

Description	Order code
0.01 micron coalescing element kit	<b>P3ZKA00ESC</b>
Adsorber element kit	<b>P3ZKA00ESA</b>
Differential pressure indicator kit	<b>P3ZKA00RQ</b>

**Regulator / Pilot Regulator**

**Symbols**

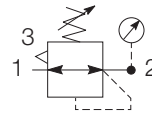

Self relieving regulator with gauge

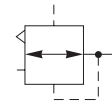

Air pilot

- Flanged 1-1/2" or 2" ports (BSPP & NPT)
- Robust die-cast aluminium construction
- Secondary pressure ranges 8 & 16 bar
- Rolling diaphragm for extended life
- Secondary aspiration plus rolling diaphragm provides quick response and accurate pressure regulation
- Air pilot regulator permanent bleed

**Options:**

<b>P 3 Z R A</b>	□	□	<b>B</b>	<b>N</b>	□	<b>N</b>	
SAE Mtg - No thread	<b>0</b>	None	<b>0</b>	Relieving	<b>B</b>	0 - 8 bar No Gauge	<b>N</b>
BSPP flange	<b>1</b>	1-1/2"	<b>B</b>			0 -16 bar No Gauge	<b>H</b>
NPT flange	<b>9</b>	2"	<b>C</b>			0 - 8 bar Gauge	<b>G</b>
						0 -16 bar Gauge	<b>J</b>
<b>P 3 Z R A</b>		□	□	<b>B P P N</b>			
For Air Pilot Regulator option							

Port size	Description	Order Code	Flow dm <sup>3</sup> /s *	Max bar	Min temp °C	Max temp °C	Height mm	Width mm	Depth mm	Weight kg
-	8 bar relieving + gauge	<b>P3ZRA00BNGN</b>	>666	17.5	0	60	230	180	132	3.5
-	8 bar relieving	<b>P3ZRA00BNNN</b>	>666	17.5	0	60	230	180	132	3.5
1-1/2"	8 bar relieving + gauge	<b>P3ZRA1BBNGN</b>	>666	17.5	0	60	230	180	132	3.5
1-1/2"	8 bar relieving	<b>P3ZRA1BBNNN</b>	>666	17.5	0	60	230	180	132	3.5
2"	8 bar relieving + gauge	<b>P3ZRA1CBNGN</b>	>666	17.5	0	60	230	180	132	3.5
2"	8 bar relieving	<b>P3ZRA1CBNNN</b>	>666	17.5	0	60	230	180	132	3.5
-	16 bar relieving + gauge	<b>P3ZRA00BNJN</b>	>666	17.5	0	60	230	180	132	3.5
-	16 bar relieving	<b>P3ZRA00BNHN</b>	>666	17.5	0	60	230	180	132	3.5
1-1/2"	16 bar relieving + gauge	<b>P3ZRA1BBNJN</b>	>666	17.5	0	60	230	180	132	3.5
1-1/2"	16 bar relieving	<b>P3ZRA1BBNHN</b>	>666	17.5	0	60	230	180	132	3.5
2"	16 bar relieving + gauge	<b>P3ZRA1CBNJN</b>	>666	17.5	0	60	230	180	132	3.5
2"	16 bar relieving	<b>P3ZRA1CBNHN</b>	>666	17.5	0	60	230	180	132	3.5
-	Pilot Regulator	<b>P3ZRA00BPPN</b>	>666	17.5	0	60	182	180	132	3.4
1-1/2"	Pilot Regulator	<b>P3ZRA1BBPPN</b>	>666	17.5	0	60	182	180	132	3.4
2"	Pilot Regulator	<b>P3ZRA1CBPPN</b>	>666	17.5	0	60	182	180	132	3.4

\* flow with 10 bar inlet 6,3 bar set pressure and 1 bar pressure drop.

**Technical Information**

Fluid:	Compressed air
Maximum inlet pressure*:	17.5 bar
Temperature range*:	0°C to +60°C
Typical flow with 10 bar inlet pressure, 8 bar set pressure and 1 bar pressure drop:	2" size >666 dm <sup>3</sup> /s
Gauge port ( x 2 ):	1/4"

\* Air supply must be dry enough to avoid ice formation at temperatures below +2°C

**Dimensions (mm)**

**Pressure regulating valve, pilot operated with integrated pilot pressure regulating valve**

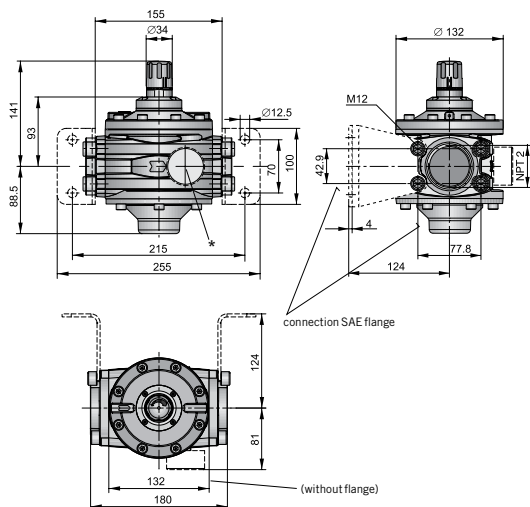

**Material Specification**

Body:	Aluminium
Bonnet:	Glass filled polyamide
Control Knob:	Glass filled polyamide
Valve:	Brass / NBR
Seals:	Nitrile NBR
Screws:	Steel / zinc plated

**Flow characteristics**

**Pressure regulating valve characteristics - (2") Pilot operated**

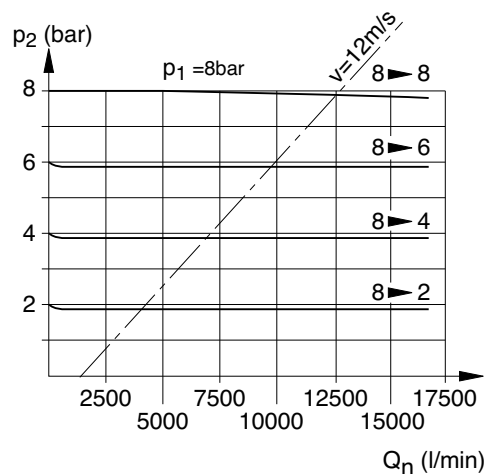

**Pressure regulating valve, pilot operated**

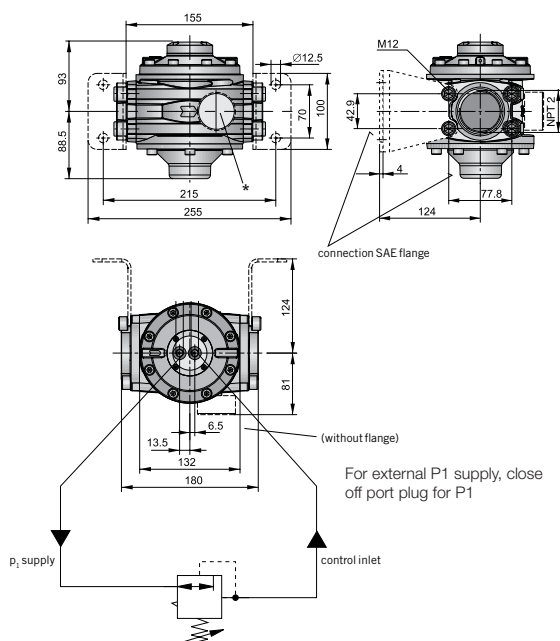

**Service kits**

Description	Order code
Diaphragm kit (relieving type)	<b>P3ZKA00RR</b>

**Lubricator**

**Symbols**

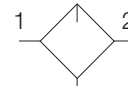
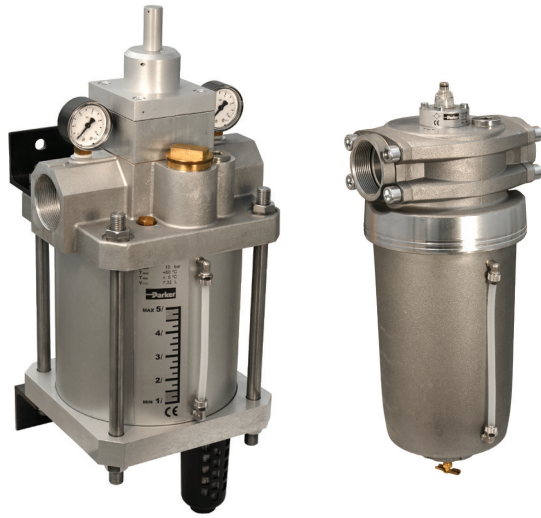

Lubricator with drain

- Flanged 1-1/2" or 2" ports (BSPP & NPT)
- Robust die-cast aluminium construction
- Proportional oil delivery over a wide range of air flows.
- Large oil reservoir

**Options:**

<b>P 3 Z L A</b>	□	□	<b>L S M N</b>
SAE Mtg - No thread	<b>0</b>	None	<b>0</b>
BSPP flange	<b>1</b>	1-1/2"	<b>B</b>
NPT flange	<b>9</b>	2"	<b>C</b>

Port size	Description	Order Code	Flow dm <sup>3</sup> /s *	Max bar	Min temp °C	Max temp °C	Bowl capacity cm <sup>3</sup>	Height mm	Width mm	Depth mm	Weight kg
-	Lubricator	<b>P3ZLA00LSMN</b>	>666	17.5	0	60	600	460	200	182	6.5
1-1/2"	Lubricator	<b>P3ZLA1BLSMN</b>	>666	17.5	0	60	600	460	200	182	6.5
2"	Lubricator	<b>P3ZLA1CLSMN</b>	>666	17.5	0	60	600	460	200	182	6.5
2"	Central airline lubricator with electrical oil level control	<b>P3ZLA1CEMMW</b>	>666	10	5	60	5000	608	250	237	18
2"	Central airline lubricator with aluminium bowl	<b>P3ZLA1CMMMW</b>	>666	10	5	60	5000	608	250	237	18

\* flow with 6,3 bar inlet pressure and 0,5 bar pressure drop.

**Technical Information**

Fluid:	Compressed air
Maximum inlet pressure*:	10 bar
Temperature range*:	5°C to +60°C

\* Air supply must be dry enough to avoid ice formation at temperatures below +2° C  
 Low flow start point (lubrication pick-up): at 6.3bar inlet pressure 0.5 dm<sup>3</sup>/s  
 Typical flow with 6.3bar inlet pressure and 0.7 bar pressure drop: 184 dm<sup>3</sup>/s

**Material Specification**

Body:	Aluminium
Sight dome:	Polyamide
Seals:	Nitrile NBR

**Dimensions (mm)**

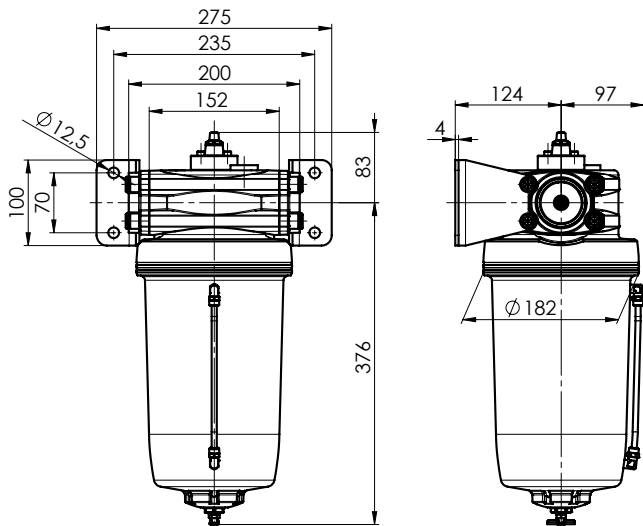

**Flow characteristics**

**(2") Lubricator**

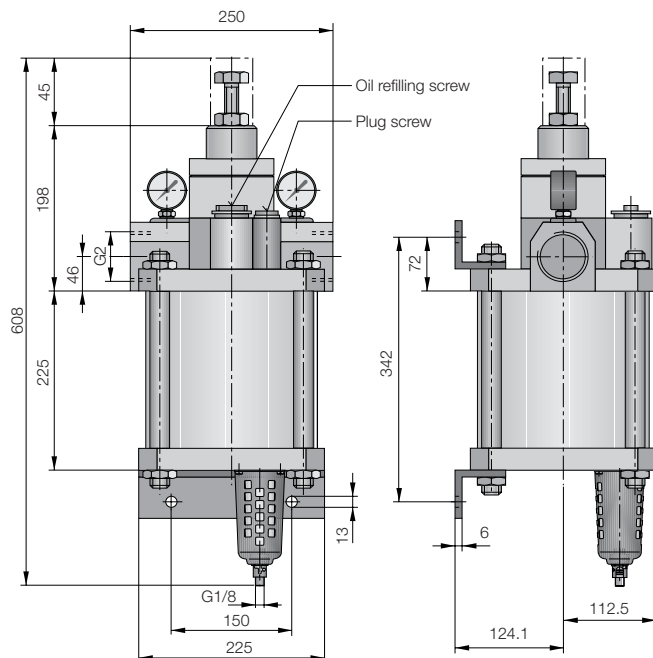
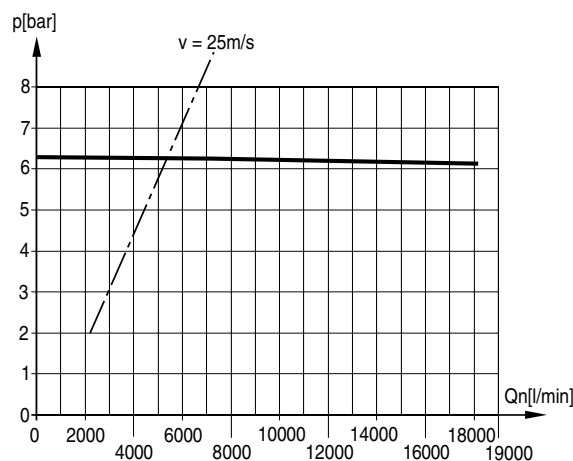

**( 2" ) Central Airline Lubricator**

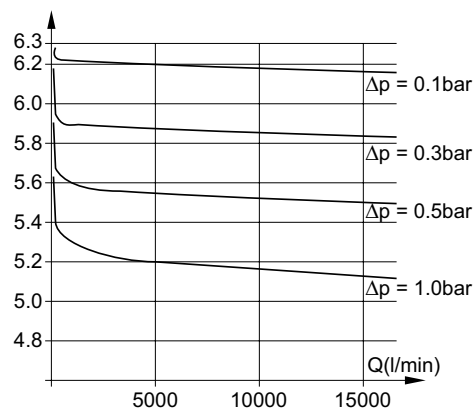

**Service kits**

Description	Order code
Drip control housing	P3ZKA00PG

**Modular Manifold**

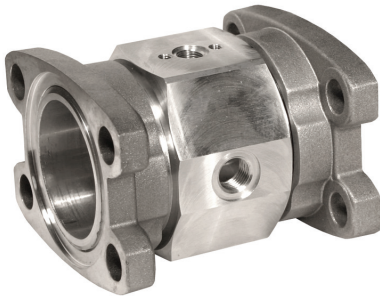

P3Z Series Manifolds, provide up to 4 extra outlet ports, they may be assembled at any position in a combination e.g. before the lubricator to provide oil free take off or at the end of a combination to provide extra outlet ports.

Thread type	Order code
BSPP	<b>P3ZMA1V0N</b>
NPT	<b>P3ZMA9V0N</b>

**Dimensions (mm)**

Inlet port	Top	Bottom	Front and Back
-	1/8"	1"	1/4"

**Material specification:**

Body:	Aluminium
Weight (kg):	1.1

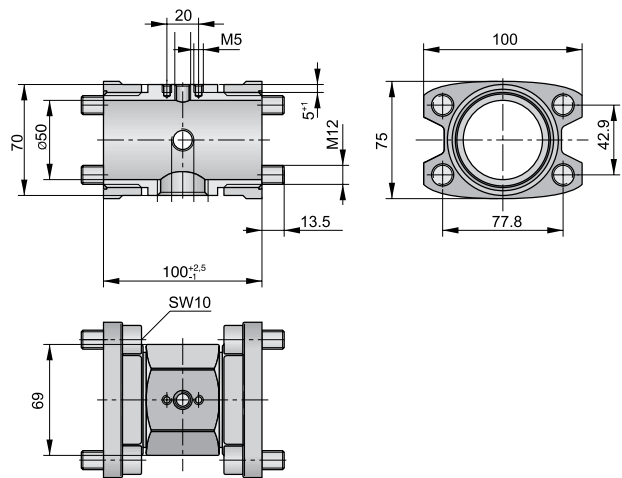

**Connection Flange Kits**

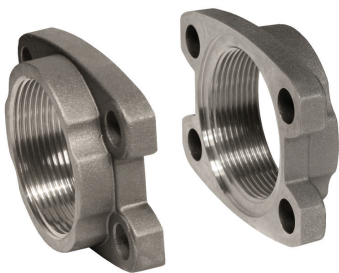

- To change port sizes connection flange kits are available, they are attached to any unit utilising the connecting kit.
- Allows assemblies to be removed from a hard piped system.





**Options:**

<b>P 3 Z K A</b>				<b>C P</b>	
BSPP (G)	1	1 1/2"	<b>B</b>		
NPT	9	2"	<b>C</b>		

**Material specification:**

Body:	Aluminium
Weight (kg):	0.6

**Accessories**

Description	Connection	Weight (kg)	Order code	
Modular wall mounting kit		0.2	<b>P3ZKA00MW</b>	
Modular coupling kit		0.8	<b>P3ZKA00CB</b>	
Pressure gauge	0 to 10 bar 0 to 16 bar	1/4" 1/4"	<b>KG8012-00</b> <b>KG8013-00</b>	
Lubricator Oil	VG32 - 1 litre	0.92	<b>P3YKA00PPBB</b>	
Modular coupling 'O' ring kit	Qty: 5		<b>P3ZKA00CCY</b>	

PDE2641TCUK

**P3Z Series air preparation system**



**HANLEY CONTROLS**

C L O N M E L

[www.hccl.ie](http://www.hccl.ie)



## Europe, Middle East, Africa

**AE -United Arab Emirates,**  
Dubai

Tel: +971 4 8127100  
parker.me@parker.com

**AT -Austria, St. Florian**

Tel: +43 (0)7224 66201  
parker.austria@parker.com

**AZ -Azerbaijan, Baku**

Tel: +994 50 2233 458  
parker.azerbaijan@parker.com

**BE/NL/LU -Benelux,**

Hendrik Ido Ambacht  
Tel: +31 (0)541 585 000  
parker.nl@parker.com

**BG -Bulgaria, Sofia**

Tel: +359 2 980 1344  
parker.bulgaria@parker.com

**BY -Belarus, Minsk**

Tel: +48 (0)22 573 24 00  
parker.poland@parker.com

**CH -Switzerland, Etoy**

Tel: +41 (0)21 821 87 00  
parker.switzerland@parker.com

**CZ -Czech Republic, Klecany**

Tel: +420 284 083 111  
parker.czechrepublic@parker.com

**DE -Germany, Kaarst**

Tel: +49 (0)2131 4016 0  
parker.germany@parker.com

**DK -Denmark, Ballerup**

Tel: +45 43 56 04 00  
parker.denmark@parker.com

**ES -Spain, Madrid**

Tel: +34 902 330 001  
parker.spain@parker.com

**FI -Finland, Vantaa**

Tel: +358 (0)20 753 2500  
parker.finland@parker.com

**FR -France, Contamine s/Arve**

Tel: +33 (0)4 50 25 80 25  
parker.france@parker.com

**GR-Greece, Piraeus**

Tel: +30 210 933 6450  
parker.greece@parker.com

**HU -Hungary, Budaors**

Tel: +36 23 885 470  
parker.hungary@parker.com

**IE - Ireland, Dublin**

Tel: +353 (0)1 466 6370  
parker.ireland@parker.com

**IL-Israel**

Tel: +39 02 45 19 21  
parker.israel@parker.com

**IT - Italy, Corsico (MI)**

Tel: +39 02 45 19 21  
parker.italy@parker.com

**KZ - Kazakhstan, Almaty**

Tel: +7 7273 561 000  
parker.easteurope@parker.com

**NO - Norway, Asker**

Tel: +47 66 75 34 00  
parker.norway@parker.com

**PL - Poland, Warsaw**

Tel: +48 (0)22 573 24 00  
parker.poland@parker.com

**PT - Portugal**

Tel: +351 22 999 7360  
parker.portugal@parker.com

**RO - Romania, Bucharest**

Tel: +40 21 252 1382  
parker.romania@parker.com

**RU - Russia, Moscow**

Tel: +7 495 645-2156  
parker.russia@parker.com

**SE - Sweden, Baras**

Tel: +46 (0)8 59 79 50 00  
parker.sweden@parker.com

**SK - Slovakia, Banská Bystrica**

Tel: +421 484 162 252  
parker.slovakia@parker.com

**SL - Slovenia, Novo Mesto**

Tel: +386 7 337 6650  
parker.slovenia@parker.com

**TR - Turkey, Istanbul**

Tel: +90 216 4997081  
parker.turkey@parker.com

**UA - Ukraine, Kiev**

Tel +48 (0) 22 573 24 00  
parker.poland@parker.com

**UK - United Kingdom, Warwick**

Tel: +44 (0)1926 317 878  
parker.uk@parker.com

**ZA - South Africa, Kempton Park**

Tel: +27 (0)11 961 0700  
parker.southafrica@parker.com

## North America

**CA - Canada, Milton, Ontario**

Tel: +1 905 693 3000

**US - USA, Cleveland**

Tel: +1 216 896 3000

## Asia Pacific

**AU - Australia, Castle Hill**

Tel: +61 (0)2-9634 7777

**CN - China, Shanghai**

Tel: +86 21 2899 5000

**HK - Hong Kong**

Tel: +852 2428 8008

**IN - India, Mumbai**

Tel: +91 22 6513 7081-85

**JP - Japan, Tokyo**

Tel: +81 (0)3 6408 3901

**KR - South Korea, Seoul**

Tel: +82 2 559 0400

**MY - Malaysia, Shah Alam**

Tel: +60 3 7849 0800

**NZ - New Zealand, Mt Wellington**

Tel: +64 9 574 1744

**SG - Singapore**

Tel: +65 6887 6300

**TH - Thailand, Bangkok**

Tel: +662 186 7000

**TW - Taiwan, Taipei**

Tel: +886 2 2298 8987

## South America

**AR - Argentina, Buenos Aires**

Tel: +54 3327 44 4129

**BR - Brazil, Sao Jose dos Campos**

Tel: +55 800 727 5374

**CL - Chile, Santiago**

Tel: +56 2 623 1216

**MX - Mexico, Toluca**

Tel: +52 72 2275 4200

European Product Information Centre

Free phone: 00 800 27 27 5374

(from AT, BE, CH, CZ, DE, DK, EE, ES, FI, FR, IE, IL, IS, IT, LU, MT, NL, NO, PL, PT, RU, SE, SK, UK, ZA)

**EMEA Product Information Centre**

Free phone: 00 800 27 27 5374

(from AT, BE, CH, CZ, DE, DK, EE, ES, FI, FR, IE, IL, IS, IT, LU, MT, NL, NO, PL, PT, RU, SE, SK, UK, ZA)

**US Product Information Centre**

Toll-free number: 1-800-27 27 537